

FURUNO

OPERATOR'S MANUAL

PRINTER

Model

PP-505-FE

(For FE-700/FE-800)

IMPORTANT NOTICES

General

- The operator of this equipment must read and follow the descriptions in this manual. Wrong operation or maintenance can cancel the warranty or cause injury.
- Do not copy any part of this manual without written permission from FURUNO.
- If this manual is lost or worn, contact your dealer about replacement.
- The contents of this manual and equipment specifications can change without notice.
- The example screens (or illustrations) shown in this manual can be different from the screens you see on your display. The screens you see depend on your system configuration and equipment settings.
- Save this manual for future reference.
- Any modification of the equipment (including software) by persons not authorized by FURUNO will cancel the warranty.
- All brand and product names are trademarks, registered trademarks or service marks of their respective holders.

How to discard this product

Discard this product according to local regulations for the disposal of industrial waste. For disposal in the USA, see the homepage of the Electronics Industries Alliance (<http://www.eiae.org/>) for the correct method of disposal.

How to discard a used battery

Some FURUNO products have a battery(ies). To see if your product has a battery(ies), see the chapter on Maintenance. Follow the instructions below if a battery(ies) is used.

In the European Union

The crossed-out trash can symbol indicates that all types of batteries must not be discarded in standard trash, or at a trash site. Take the used batteries to a battery collection site according to your national legislation and the Batteries Directive 2006/66/EU.

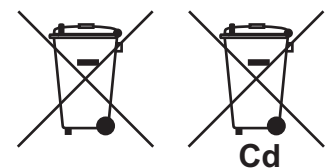

In the USA

The Mobius loop symbol (three chasing arrows) indicates that Ni-Cd and lead-acid rechargeable batteries must be recycled. Take the used batteries to a battery collection site according to local laws.

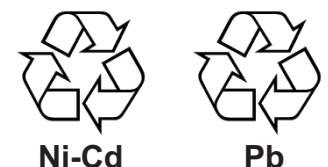



In the other countries

There are no international standards for the battery recycle symbol. The number of symbols can increase when the other countries make their own recycle symbols in the future.





SAFETY INSTRUCTION

Read these safety instructions before you operate the equipment.

 WARNING	Indicates a condition that can cause death or serious injury if not avoided.
 CAUTION	Indicates a condition that can cause minor or moderate injury if not avoided.



 Warning, Caution	 Prohibitive Action	 Mandatory Action
--	--	---

Safety Information for Operator

 WARNING
 <p>Do not open the cover of the equipment.</p> <p>This equipment uses high voltage electricity which can shock or burn. Only qualified personnel should work inside the equipment.</p>
<p>Do not disassemble or modify the equipment.</p> <p>Fire, electrical shock or serious injury can result.</p>
<p>Immediately turn off the power at the ship's mains switchboard if water or foreign object falls into the equipment or the equipment is emitting smoke or fire.</p> <p>Continued use of the equipment can cause fire, electrical shock or serious injury.</p>

 CAUTION
<p>Do not operate the unit with wet hands.</p> <p>Electrical shock can result.</p>
<p>Use the correct fuse.</p> <p>Use of the wrong fuse can cause fire or damage the equipment.</p>





Safety Information for Installer

 WARNING
 <p>ELECTRICAL SHOCK HAZARD</p> <p>Only qualified personnel should work inside the equipment.</p> <p>This equipment uses high voltage electricity which can shock or burn.</p>
<p>Turn off the power at the ship's mains switchboard before beginning the installation. Post a warning sign near the switchboard to ensure that the power will not be applied while the equipment is being installed.</p> <p>Serious injury can result if the power is not turned off, or is applied while the equipment is being installed.</p>

 CAUTION						
<p>Observe the following compass safe distances to prevent interference to a magnetic compass:</p> <table border="1"> <thead> <tr> <th></th> <th>standard compass</th> <th>steering compass</th> </tr> </thead> <tbody> <tr> <td>PP-505</td> <td>1.1 m</td> <td>0.8 m</td> </tr> </tbody> </table>		standard compass	steering compass	PP-505	1.1 m	0.8 m
	standard compass	steering compass				
PP-505	1.1 m	0.8 m				

WARNING LABEL

A warning label is attached to the printer. Do not remove the label. If the label is missing or damaged, contact your dealer about replacement.

 WARNING 
To avoid electrical shock, do not remove cover. No user-serviceable parts inside.
 

Name: Warning Label (1)
Type: 86-003-1011
Code No.: 100-236-231

FOREWORD

A Word to the Owner of the PP-505

Congratulations on your choice of the FURUNO PP-505 Printer.

For 60 years FURUNO Electric Company has enjoyed an enviable reputation for innovative and dependable marine electronics equipment. This dedication to excellence is furthered by our extensive global network of agents and dealers.

Your printer is designed and constructed to meet the rigorous demands of the marine environment. However, no machine can perform its intended function unless installed, operated and maintained properly. Please carefully read and follow the recommended procedures for installation, operation and maintenance.

We would appreciate hearing from you, the end-user, about whether we are achieving our purposes.

Thank you for considering and purchasing FURUNO equipment.

The PP-505 prints a depth graph or a log consisting of date, time, depth, draft, latitude, longitude and heading.

You can choose which to print with the [MODE] key.

The main features are

- Automatic operation; just turn on the power and the printer readies itself for printing.
- Selectable printing interval.
- LEDs show equipment status.

TABLE OF CONTENTS

1. OPERATION	1
1.1 General	1
1.2 Panel.....	1
1.3 Turning on the Power	2
2. REPLACEMENT OF THERMAL PAPER.....	3
3. INSTALLATION	4
3.1 Complete Set	4
3.2 General Mounting Considerations	4
3.3 Tabletop/Bulkhead Mount	5
3.4 Flush Mount	5
3.5 Wiring.....	6
4. MAINTENANCE	7
APPENDIX REPLACEMENT OF PRINTER ASSEMBLY/THERMAL HEAD	AP-1
SPECIFICATIONS	SP-1
PACKING LIST.....	A-1
OUTLINE DRAWING.....	D-1
INTERCONNECTION DIAGRAM	S-1

1. OPERATION

1.1 General

Operation of the PP-505 is simple; just turn on the power. The depth graph or the log, whichever is selected for printing, is printed out at the interval set.

Below are example printouts.

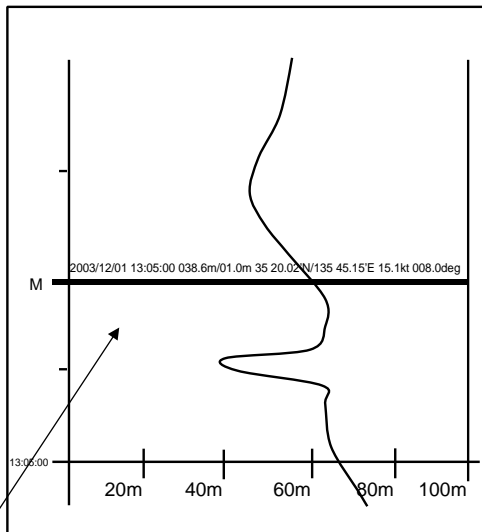

Depth graph

2003/12/01	13:05:00	038.6m/01.0m	35	20.02°N	135 45.15°E	15.1kt	008.0deg
2003/12/01	13:05:00	038.6m/01.0m	35	20.02°N	135 45.15°E	15.1kt	008.0deg
2003/12/01	13:05:00	038.6m/01.0m	35	20.02°N	135 45.15°E	15.1kt	008.0deg
2003/12/01	13:05:00	038.6m/01.0m	35	20.02°N	135 45.15°E	15.1kt	008.0deg
2003/12/01	13:05:00	038.6m/01.0m	35	20.02°N	135 45.15°E	15.1kt	008.0deg

Depth data log

Marker

1.2 Panel

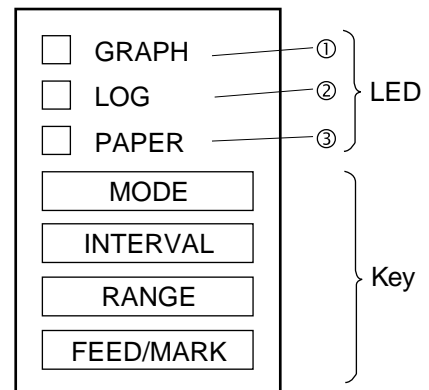
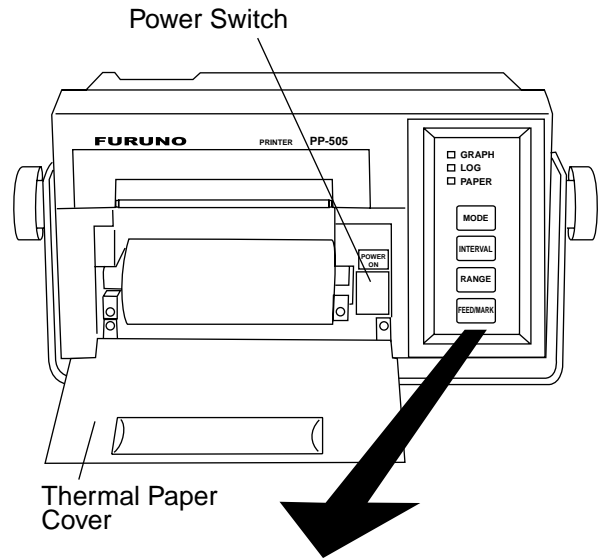

Indicators

There are three (red) LEDs on the front panel which light or blink according to equipment status.

- ① GRAPH
Lights while the depth graph is being printed.
- ② LOG
Lights while the depth data log is being printed.
- ③ PAPER
Blinks when the paper has run out, and is accompanied by the audible alarm. The audible alarm sounds for five seconds; you may silence it sooner by hitting any key.

Changing the mode

Press the [MODE] key to change the printing mode from depth graph to log printing alternately.

The printing interval setting is printed whenever the [MODE] key is pressed.

Changing the printing interval

Press the [INTERVAL] key to choose printing interval.

Depth graph: 9 s → 45 s → 90 s → 450 s
Log: 10 s → 30 s → 1 m → 10 m

The latest data of the printing interval is printed.

When the printing interval is changed, the printing interval setting is printed and marked with an asterisk.

Note: You can skip over setting(s) by pressing the key consecutively within one second.

Changing the depth range

Press the [RANGE] key to change the depth range.

When the depth range is changed, the depth is printed and marked with an asterisk.

Range: 5 m → 10 m → 20 m → 40 m →
100 m → 200 m → 400 m → 800 m

Note1: Depth range automatically changes depending on the depth range on the navigational echo sounder.

Note2: You can skip over setting(s) by pressing the key consecutively within one second.

Feeding the paper/Printing the marker

To feed the paper, press and hold down the [FEED/MARK] key.

Press the [FEED/MARK] key momentarily to print the marker.

1.3 Turning on the Power

Flip down the thermal paper cover and turn on the [POWER] switch. The PP-505 then carries out the diagnostic test. After the test has been completed, the printer is ready to print depth data.

Note: "Disconnect" is printed if data from the navigation echo sounder is not being received during printing or the navigation echo sounder is displaying the system menu.

To turn off the power, press the [POWER] switch.

2. REPLACEMENT OF THERMAL PAPER

When the thermal paper runs out, the PAPER LED blinks, printing stops automatically and the aural alarm sounds for five seconds.

With 1 meter of paper remaining, a red paper end mark appears on the paper. When the red mark appears, replace the thermal paper as shown in the procedure below.

REQUIRED THERMAL PAPER
 Type: TP0340 (112 mmx40 m)
 Code No.: 000-801-765
 Be sure to use the specified thermal paper.

1. Press the [FEED/MARK] key to draw out the remaining thermal paper.
2. Pull the thermal paper cover forward and take out the paper spool.
3. Curve the leading edge of the new roll paper to ensure smooth feeding, and set the paper spool to the new roll paper.

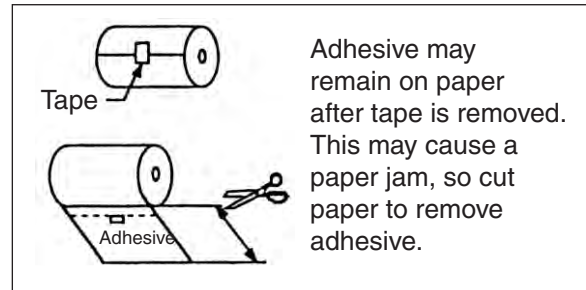
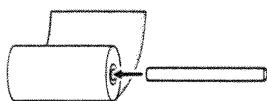
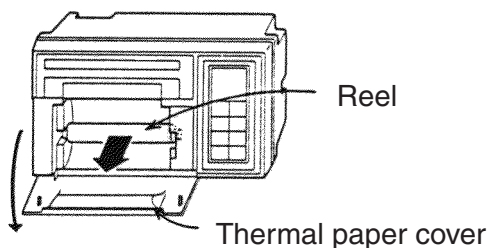
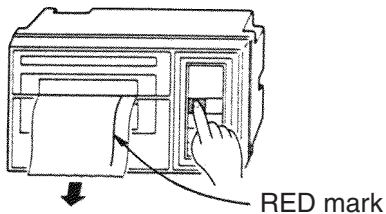

4. Insert the paper into the paper insertion slot just above the paper container and press the [FEED/MARK] key to feed out the paper.
5. Set the paper in the paper container.

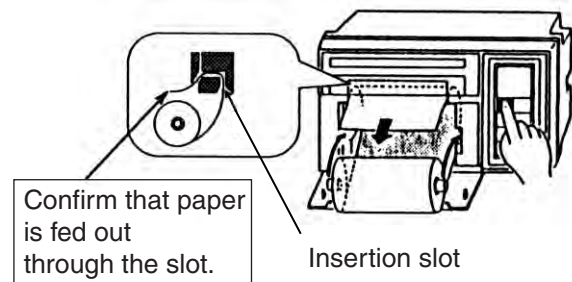

6. Press the [FEED/MARK] key to confirm that the paper is properly aligned.
 If the paper comes out with its edges wrinkled, continue to press the [FEED/MARK] key. Correct alignment will be made automatically.
7. Close the thermal paper cover.
8. Press the [MODE] key to complete the replacement of thermal paper. (The PAPER LED goes off.)

Note: If the PP-505 receives data when there is no paper it doesn't print them out after replacing the thermal paper.

Remedy for paper jam

If the paper is jammed cut it off at the front panel and rewind it into the paper container by hands.

3. INSTALLATION

3.1 Complete Set

Name	Type	Mass	Qty	Remark
Main Unit	PP-505	3.1 kg (with hanger)	1	
Spare Parts	SP08-01600		1	
Installation Materials	CP16-00800		1	
Accessories	FP08-00500		1	
Flush Mount Kit	OP08-4		1	Option (004-511-330)

3.2 General Mounting Considerations

This equipment can perform its intended functions only if it is installed properly. Keep in mind the following when selecting a mounting location.

Water spray

The PP-505 is designed and constructed to be able to withstand the humidity and corrosive atmosphere common to the pilothouse, but it is not designed to be used outside, directly exposed to the environment. Salt water spray will most assuredly cause damage to the sensitive components inside.

Mechanical shock and vibration

The PP-505 is constructed to withstand minor shocks and engine vibration, but excessive and continued shock can shorten the life of the precision printer mechanism. Shock may also degrade the print quality due to uneven contact between the printer head and the thermal paper.

Heat accumulation

The PP-505 consumes very little power, so there is no need for forced air ventilation. However, it is recommended to provide at least some space around the unit to allow for circulation of cooling air.

The unit should be kept out of direct sunlight because of heat that can build up inside the cabinet. Excessive heat can darken the thermal paper.

Onboard noise

To avoid mutual interference with other power equipment, do not install this unit near a power cable or equipment having a motor.

Compass safe distance

A magnetic compass will be affected if the printer is placed too close to the compass. Observe the following compass safe distances to prevent deviation to the compass.

Standard: 1.1 m

Steering: 0.8 m

3.3 Tabletop/Bulkhead Mount

The main unit can be mounted on a desktop, bulkhead, or in a panel. Make sure the selected location is strong enough to support the main unit against possible vibration and shock. If necessary, appropriate reinforcement measures should be made on the mounting area.

Tabletop mount

1. Drill four pilot holes for the hanger.
2. Fix the hanger with the tapping screws (5×20) supplied.
3. Place the unit in the hanger and tighten knobs.

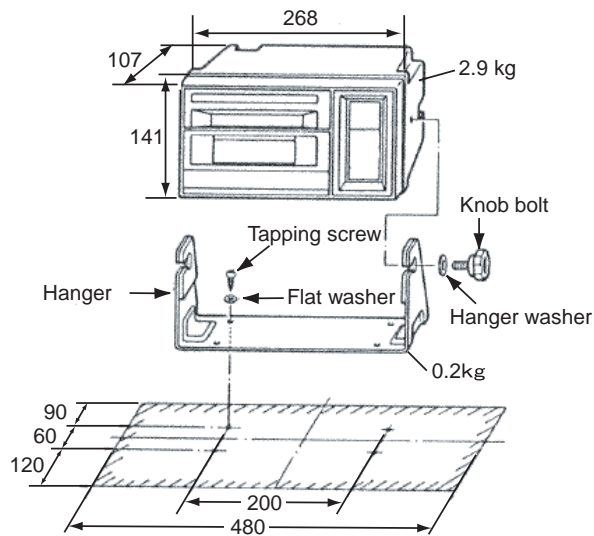

Bulkhead mount

When the unit is installed on the bulkhead, fix the hanger as shown below.

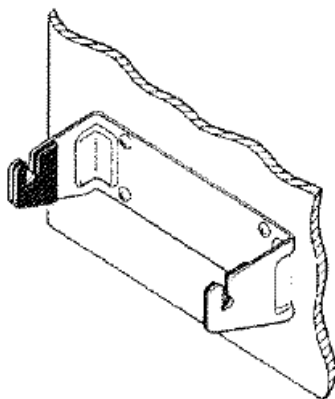

3.4 Flush Mount

Flush mount panel kit is optionally supplied.

Flush mount kit OP08-4 (Code No.: 004-511-330)

Name	Type	Code No.	Qty.
Flush mount panel	22-008-0125	100-103-351	1
Tapping screw	5x20	000-163-867-10	4
Nylon washer	2.8x7x0.5	000-800-728	4
Pan head screw	M3x8	000-163-669-10	4
Hex. bolt	M8x16	000-162-291-10	2
Flat washer	M5	000-864-128	4
Flat washer	M8	000-864-130	2
Spring washer	M8	000-864-262	2
Rosette washer	M3	000-864-900	4
Flush mount angle	22-008-0126	100-103-361-10	2
Liner	22-008-0127	100-103-371	2

3. INSTALLATION

1. Referring to the illustration below, prepare a cutout in the mounting area and drill four pilot holes for the flush mount angles. Refer to the outline drawing at end of manual.
2. Fix the liner and the flush mount angles to the main unit.
3. Connect the cables at the rear of main unit.
4. Fix the main unit to the panel cutout with four tapping screws.
5. Fix the flush mount panel to the flush mount angles with the screws and washers supplied.

3.5 Wiring

Refer to the interconnection diagram at end of manual for connection.

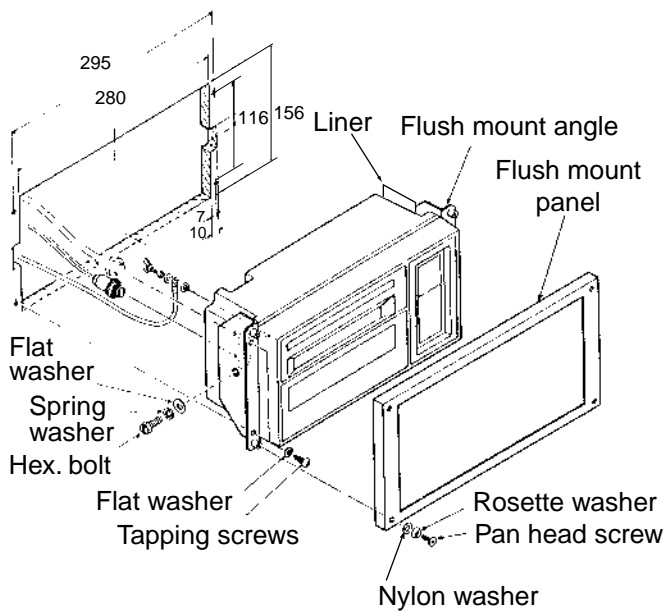

4. MAINTENANCE

Checking the power connector

Check for loosened or disconnected power connector.

 WARNING	
	Do not open the cover of the equipment. This equipment uses high voltage electricity which can shock or burn. Only qualified personnel should work inside the equipment.
Do not disassemble or modify the equipment. Fire, electrical shock or serious injury can result.	

Diagnostic test

When turning on the power, if any fault is detected, the appropriate LED lights.

GRAPH: ROM error

LOG: RAM1 error

PAPER: RAM2 error

If any LEDs light, contact your dealer.

Cleaning

Accumulated dust should be regularly removed from both exterior surfaces and the interior. The only recommended cleaning material for exterior surfaces is a soft cloth. For the interior, use a handheld vacuum. **BE SURE TO TURN OFF THE POWER BEFORE CLEANING THE INSIDE OF THE UNIT.** Do not use chemical-based cleaners to clean the display unit—they can remove paint and markings.

Fuse Replacement

To protect the equipment from serious damage, a 3A fuse is provided on the rear cabinet of the main unit. The fuse protects against overvoltage/reverse polarity of the ship's mains or internal fault of the equipment. If the fuse has blown, first find out the cause of the trouble before replacing it. A fuse rated for more than 3 A should not be used, since it may permanently damage the equipment. Damage due to overfusing is not covered by the warranty.

 CAUTION
Use the correct fuse. Use of the wrong fuse can cause fire or damage the equipment.

APPENDIX REPLACEMENT OF PRINTER ASSEMBLY/TERMAL HEAD

1. Loosen the four M4 × 15 screws fixing the rear cabinet to the main unit assembly.
2. Disconnect the connectors connected to the rear cabinet to detach the rear cabinet.

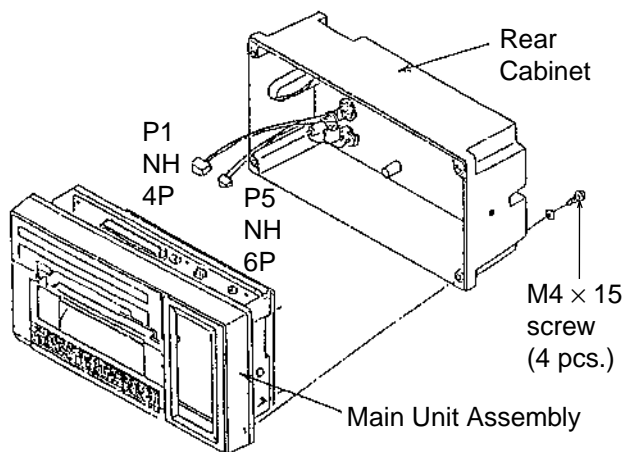

4. Move the carriage to position (A) by rotating the carriage shaft by fingers, as shown below, where the thermal head assembly can be replaced easily.

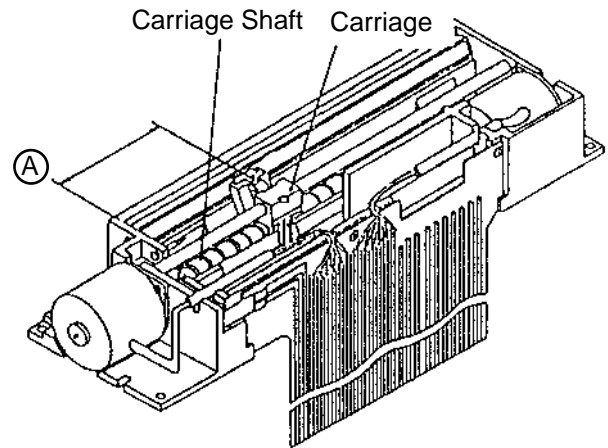

3. Separate the panel assembly from the main unit assembly by removing the recording paper from the paper container.

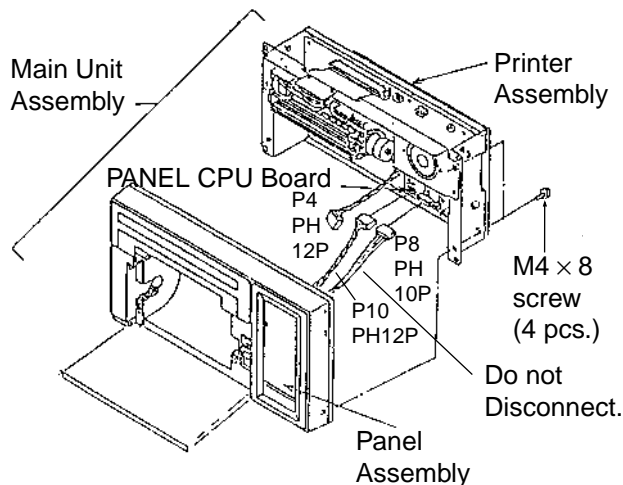

5. Remove the flexible cable support from the carriage by lifting it toward direction (B) as in the figure below.

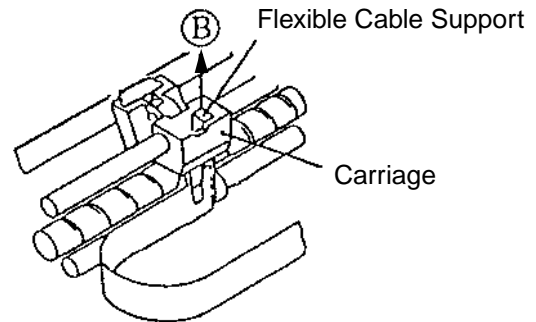

6. Pull out the connector end of the flexible cable from the connector. Take care not to damage the flexible cable.

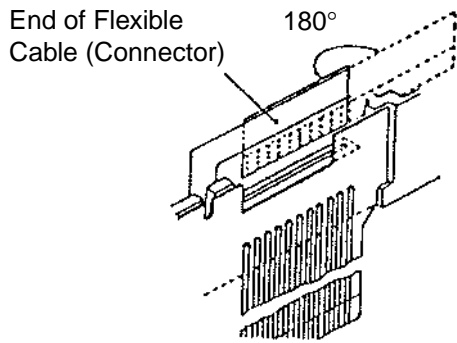

7. Remove the thermal head from the head holder with a screwdriver as shown below, and then take the thermal head assembly out of the printer assembly.

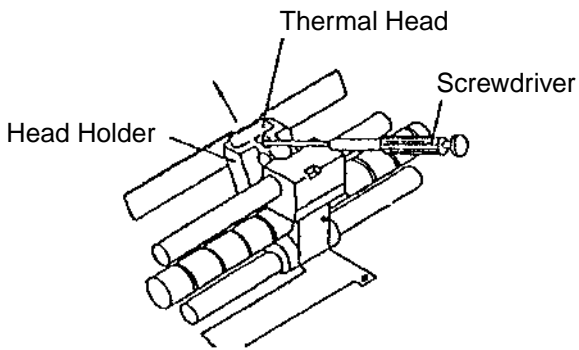

8. As shown below, pass the flexible cable (connector side) of a new thermal head assembly beneath the guide pins.

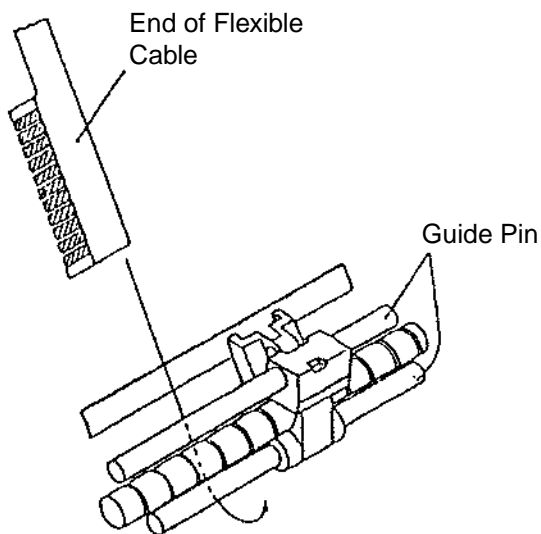

9. Hold the flexible cable end with a tweezers and pull it out until it is positioned as shown below.

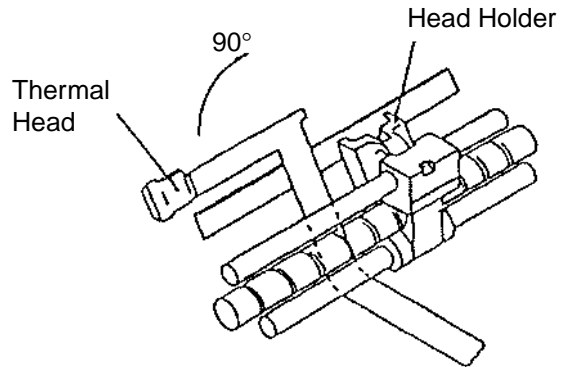

10. Turn the head by 90° so that it is parallel with the head holder as shown below. While pulling the head holder toward you, insert the head into the head holder.

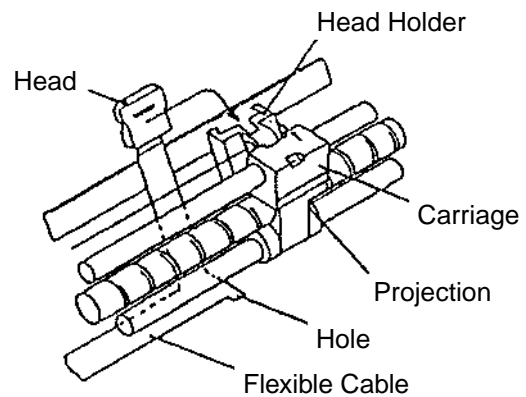

11. Fix the flexible cable to the carriage with the flexible cable support, inserting the projection on the carriage into the hole of the cable.

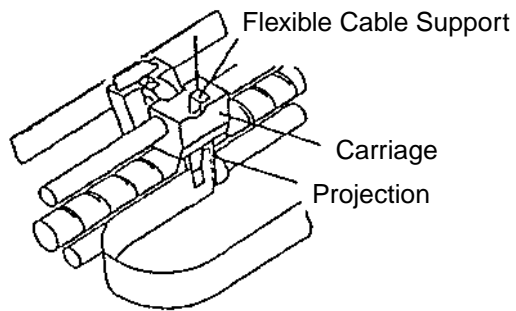

12. Fold back the end of the cable and insert it into the connector.

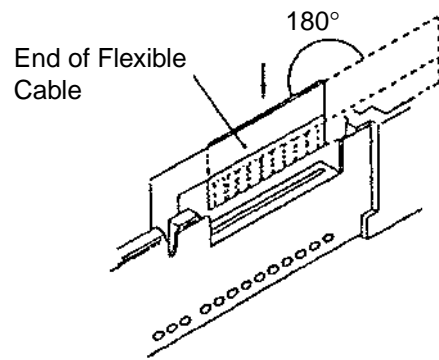

**SPECIFICATIONS OF PRINTER
PP-505-FE (PRINTER FOR FE-700/800)**

1 DATA FORMAT

- 1.1 Receiving system RS-232C
- 1.2 Speed 9600 bps
- 1.3 Data length 8 bits
- 1.4 Parity Non
- 1.5 Stop bit 1 bit

2 PRINTER SECTION

- 2.1 Printing system 9 dots serial thermal head printing system
- 2.2 Character Alphanumeric
- 2.3 Dot pitch 0.28 mm/ dot
- 2.4 Number of dot in line 300 dots
- 2.5 Number of characters Max. 80 characters/ line
- 2.6 Print speed 31 cps
- 2.7 Roll paper TP-0340, 112 mm (W) x 40 m (L)

3 POWER SUPPLY

12-24 VDC, 15 W max. (receiving), 9 W (stand-by)

4 ENVIRONMENTAL CONDITION

- 4.1 Ambient temperature -15°C to +55°C
- 4.2 Relative humidity 95% at 40°C
- 4.3 Waterproofing IPX0
- 4.4 Bearing vibration IEC 60945







5 COATING COLOR

Chassis: 2.5GY5/1.5, Panel: N3.0

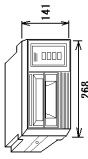
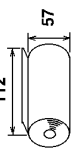
PACKING LIST

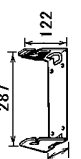
PP-505-FE

A-1

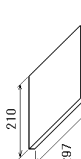
NAME	UNIT	OUTLINE	DESCRIPTION/CODE No.	QTY
ユニット				
プリンター			PP-505-FE	1
予備品				
記録紙(感熱)			TP0340 112MM X40M	1
RECORDING PAPER (THERMAL)			000-801-765-10	
予備品			SP08-01000	1
SARE PARTS			000-040-143-00	
付属品				
ハンガ-組品			FP08-00550	1
HANGER FIXING SCREW KIT			004-511-570-00	
ハンガ-組品			FP08-00510	1
HANGER ASSY.			004-511-550-00	
工事材料				
ケーブル組品			08S0157	1
POWER CABLE ASSY.			08S0157-2	
			000-116-030-11	
			000-116-030-00	
コネクタ			CP16-00810	1
CONNECTOR			005-948-060-00	
図書				
取扱説明書(英)			OME-23662-*	1
OPERATOR'S MANUAL			000-148-220-1*	
取扱説明書(和)			OMJ-23662-*	1
OPERATOR'S MANUAL			000-148-219-1*	

型式/コード番号が空段の場合、下段より上段に代わる過渡期品であり、どちらかが入っています。なお、品質は変わりません。
TWO TYPES AND CODES MAY BE LISTED FOR AN ITEM. THE LOWER PRODUCT MAY BE SHIPPED IN PLACE OF THE UPPER PRODUCT. QUALITY IS THE SAME.
(略図の寸法は、参考値です。 DIMENSIONS IN DRAWING FOR REFERENCE ONLY.)

A-2

FURUNO

工事材料表

PP-505-*

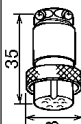
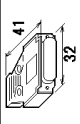
番号	名称	略図	型名/規格	数量	用途/備考
INSTALLATION MATERIALS					
1	7-糸線 GROUNDING WIRE		08S0087-0 CODE NO. 000-108-138-10	1	
2	コネクタ (FM14) CONNECTOR		FM14-7P CODE NO. 000-166-038-10	1	
3	コネクタ (XM2) CONNECTOR (D-SUB)		XM2S-0913-S012 CODE NO. 001-115-840-10	1	

型式/コード番号が2段の場合、下段より上段に代わる過渡期品であり、どちらかが入っています。なお、品質は変わりません。
TWO TYPES AND CODES MAY BE LISTED FOR AN ITEM. THE LOWER PRODUCT MAY BE SHIPPED IN PLACE OF THE UPPER PRODUCT. QUALITY IS THE SAME.
(略図の寸法は、参考値です。 DIMENSIONS IN DRAWING FOR REFERENCE ONLY.)

寸法区分 (mm) Dimensions	公差 (mm) Tolerance
L ≤ 50	± 1.5
50 < L ≤ 100	± 2.5
100 < L ≤ 500	± 3

表 1 TABLE 1

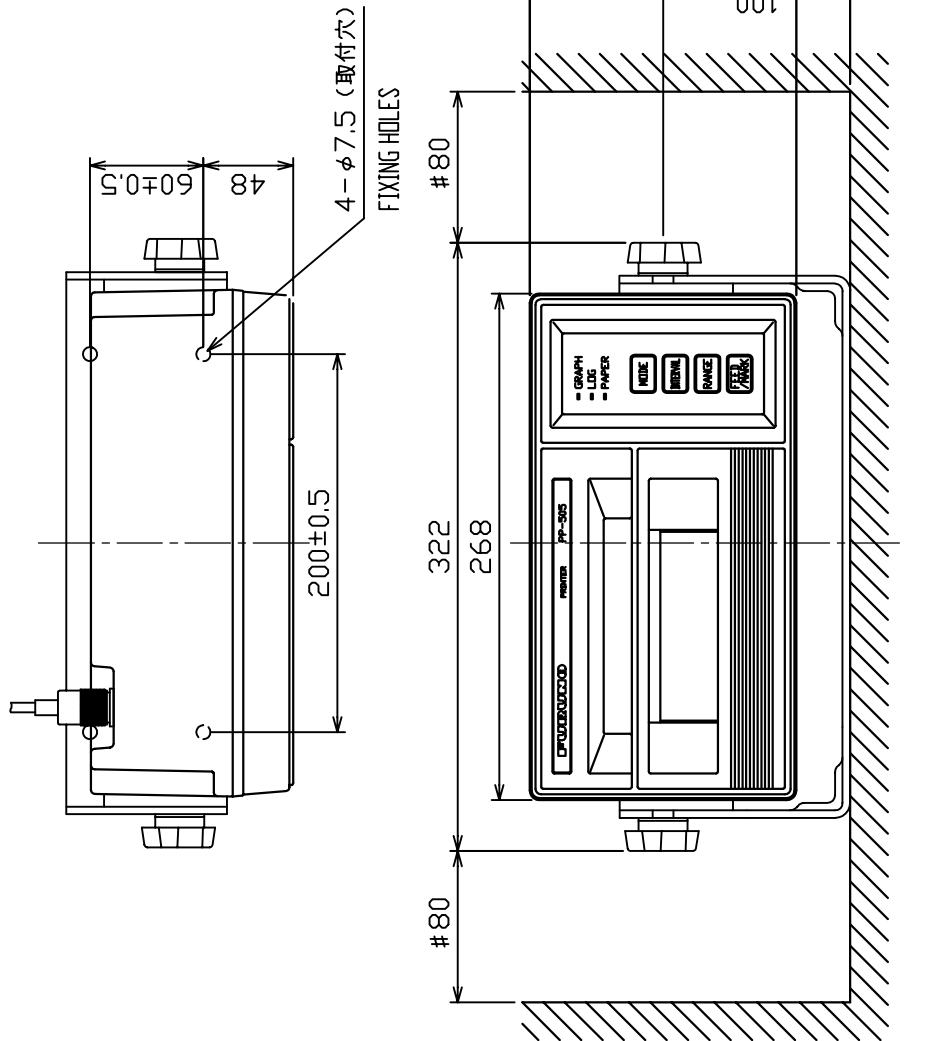

注 記 1) # 印寸法は最小サービス空間寸法とする。
 2) 指定外の寸法公差は表 1 による。

NOTE 1. # RECOMMENDED SERVICE CLEARANCE.
 2. TABLE 1 INDICATES TOLERANCE OF DIMENSIONS WHICH IS NOT SPECIFIED.

DRAWN	Dec. 5 '03	T. Shishido	TITLE	PP-505-FF
CHECKED	Dec. 5 '03	T. Takano	名 称	プリンタ
APPROVED	Dec. 08 '03	T. Masaguchi	外寸図 (卓上装備)	
SCALE	1/4	MASS 2.9 kg	NAME	PRINTER (TABLETOP MOUNT)
DWG No.	C2366-G10-B			OUTLINE DRAWING
				16-010-005G-0

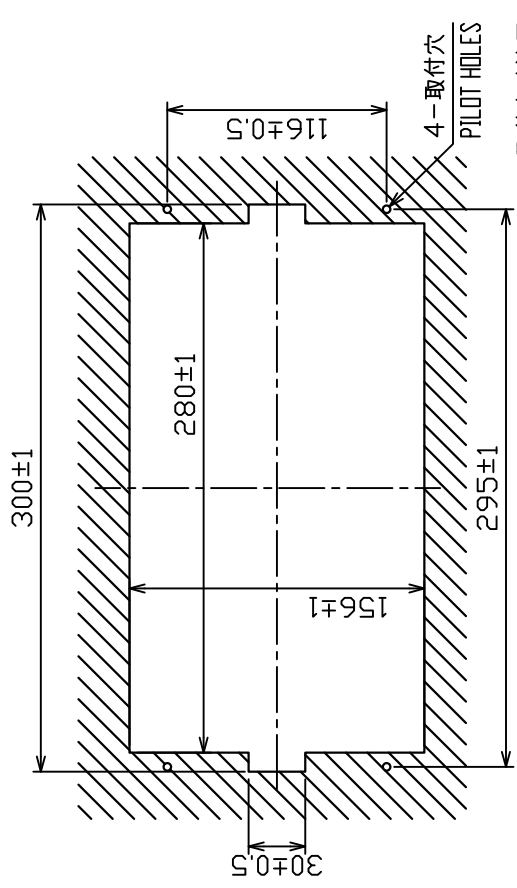

取付穴寸法図
CUTOUT DIMENSIONS

表 1 TABLE 1

寸法区分 (mm) DIMENSION	公差 (mm) TOLERANCE
L ≤ 50	±1.5
50 < L ≤ 100	±2.5
100 < L ≤ 500	±3

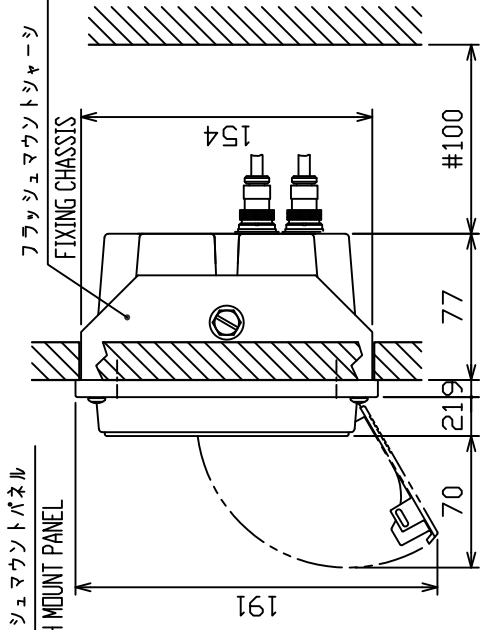
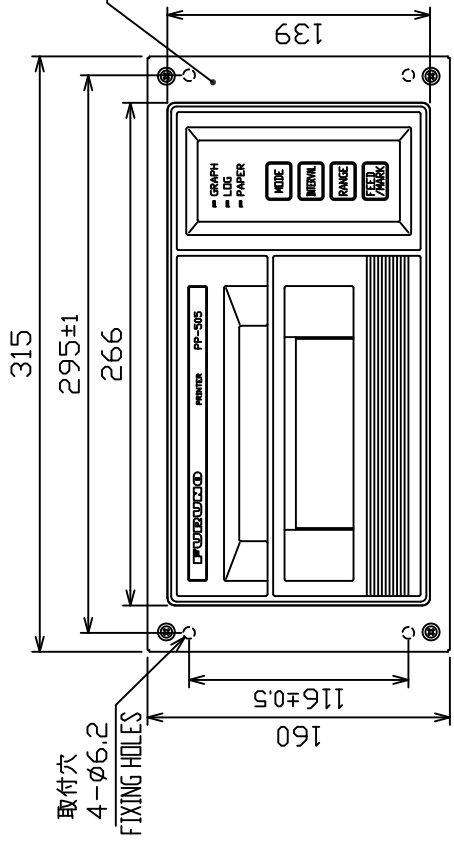
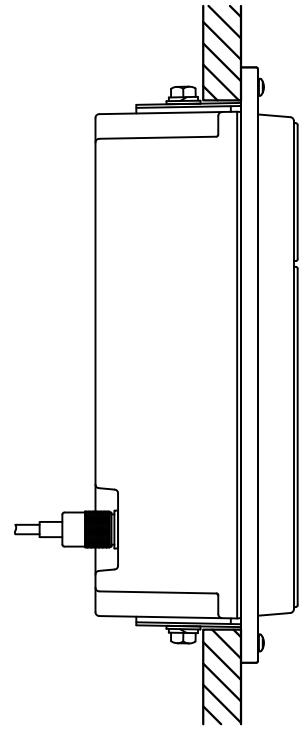

注 記

- 1) 指定外の寸法公差は表 1 による。
 - 2) #印は最小サービスインスペーシングとする。
 - 3) 取付用ネジは M5 ボルトまたはタッピングネジ呼び径φ5 を使用のこと。
- NOTE
1. TABLE 1 INDICATES TOLERANCE OF DIMENSIONS WHICH IS NOT SPECIFIED.
 2. # MINIMUM SERVICE CLEARANCE.
 3. USE M5 BOLTS OR TAPPING SCREWS φ5 FOR FIXING THE UNIT.

DRAWN	3/Sep/09	T. YAMASAKI	TITLE	PP-505-FE
CHECKED	3/Sep/09	T. TAKENO	名称	プリンタ(埋込装置)
APPROVED	4/Sep/09	R. Esumi	外寸図	
SCALE	1/4	質量 2.9 kg	NAME	PRINTER (FLUSH MOUNT)
DWG. No.	C2366-G11-C		REF. No.	16-010-015G-1

4

3

2

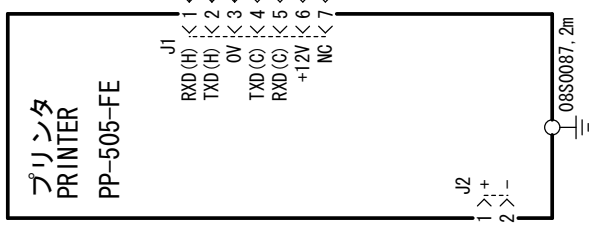
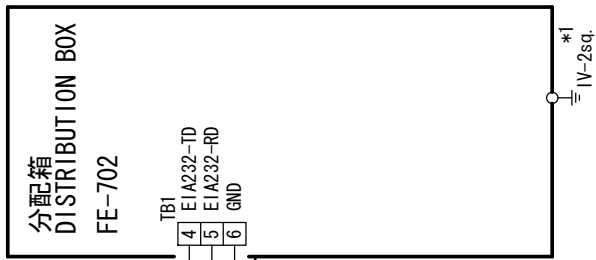

*1
TPYCYS-1.5. MAX. 10m

FM14-7P

J1

RXD(H) < 1
TXD(H) < 2
OV < 3
TXD(C) < 4
RXD(C) < 5
+12V < 6
NC < 7

*3

*2
FM14-2P

アカ RED → 1 > +
ク ロ BLK → 2 > -

08S0157, 3m

12-32 VDC

08S0087, 2m

08S0087, 2m

注記

- * 1) 造船所手配。
- * 2) 工場にて取付済み。
- * 3) コネクタケースでアースをとる。

NOTE

- * 1: SHIPYARD SUPPLY.
- * 2: FITTED AT FACTORY.
- * 3: GROUND THRU CONNECTOR CLAMP.

DRAWN	21/Apr/2014	I. YAMASAKI	TITLE	PP-505-FE
CHECKED	21/Apr/2014	H. MAKI	名称	プリンタ
APPROVED	21/Apr/2014	H. MAKI	相互結線図	相互結線図
SCALE	MASS		NAME	PRINTER
DWG. No.	C2366-C03-F	REF. No.	16-006-3022-0	INTERCONNECTION DIAGRAM

ECF

(Elemental Chlorine Free)

The paper used in this manual
is elemental chlorine free.

FURUNO ELECTRIC CO., LTD.

9-52 Ashihara-cho,
Nishinomiya, 662-8580, JAPAN

• FURUNO Authorized Distributor/Dealer

All rights reserved. Printed in Japan

Pub. No. OME-23662-A4

(TAHA) PP-505-FE

A : JUL. 2003

A4 : MAY 26, 2014



0 0 0 1 4 8 2 2 0 1 0