

FURUNO

OPERATOR'S MANUAL

Bottom Discrimination Sounder

Model

BBDS1

Multi-Language Operator's Guide
Download Link

Multi-Language Operator's Guide gives you the basic information on the operation of this model. Please visit our website from the following two-dimensional code and download.



Operator's Guide is available in the following languages.

English, French, Spanish, German, Italian, Portuguese, Danish, Swedish, Norwegian, Finnish, Dutch and Japanese.

IMPORTANT NOTICES

General

- This manual has been authored with simplified grammar, to meet the needs of international users.
- The operator of this equipment must read and follow the instructions in this manual. Wrong operation or maintenance can void the warranty or cause injury.
- Do not copy any part of this manual without written permission from FURUNO.
- If this manual is lost or worn, contact your dealer about replacement.
- The contents of this manual and the equipment specifications can change without notice.
- The example screens (or illustrations) shown in this manual can be different from the screens you see on your display. The screens you see depend on your system configuration and equipment settings.
- Save this manual for future reference.
- Any modification of the equipment (including software) by persons not authorized by FURUNO will void the warranty.
- The following concern acts as our importer in Europe, as defined in DECISION No 768/2008/EC.
 - Name: FURUNO EUROPE B.V.
 - Address: Siriusstraat 86, 5015 BT, Tilburg, The Netherlands
- The following concern acts as our importer in UK, as defined in SI 2016/1025 as amended SI 2019/470.
 - Name: FURUNO (UK) LTD.
 - Address: West Building Penner Road Havant Hampshire PO9 1QY, U.K.
- All brand, product names, trademarks, registered trademarks, and service marks belong to their respective holders.

How to discard this product

Discard this product according to local regulations for the disposal of industrial waste. For disposal in the USA, see the homepage of the Electronics Industries Alliance (<http://www.eiae.org/>) for the correct method of disposal.

How to discard a used battery

Some FURUNO products have a battery(ies). To see if your product has a battery, see the chapter on Maintenance. If a battery is used, tape the + and - terminals of the battery before disposal to prevent fire, heat generation caused by short circuit.

In the European Union

The crossed-out trash can symbol indicates that all types of batteries must not be discarded in standard trash, or at a trash site. Take the used batteries to a battery collection site according to your national legislation and the Batteries Directive 2006/66/EU.

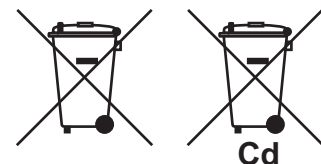

In the USA

The Mobius loop symbol (three chasing arrows) indicates that Ni-Cd and lead-acid rechargeable batteries must be recycled. Take the used batteries to a battery collection site according to local laws.

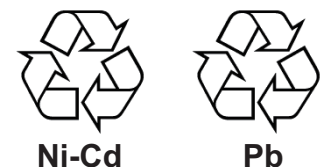



In the other countries

There are no international standards for the battery recycle symbol. The number of symbols can increase when the other countries make their own recycle symbols in the future.









SAFETY INSTRUCTIONS





The user and installer must read the appropriate safety instructions before attempting to install or operate the equipment.

 WARNING	Indicates a potentially hazardous situation which, if not avoided, could result in death or serious injury.
 CAUTION	Indicates a potentially hazardous situation which, if not avoided, may result in minor or moderate injury.





 Warning, Caution	 Prohibitive Action	 Mandatory Action
--	--	--

Safety instructions for the operator

 WARNING	
	Do not open the equipment. Only qualified personnel should work inside the equipment.
	Do not disassemble or modify the equipment. Fire, electrical shock or serious injury can result.
	Turn off the equipment immediately if it is emitting smoke or fire. Fire or electrical shock can result if the power is left on.
	Turn off the power immediately if water leaks into the equipment or an object is dropped inside the equipment. Continued use can cause fire or electrical shock.
	Turn off the power immediately if you feel the equipment is acting abnormally. If the equipment is very warm or is emitting strange noises turn off the power immediately and contact your dealer for advice.





 WARNING	
	Do not operate the equipment with wet hands. Electrical shock can result.
	Do not place liquid-filled containers on the top of the equipment. Electrical shock can result.
	Do not install the equipment where it may be subjected to rain or water splash. Fire or electrical shock can result if water gets inside the equipment.
	Use the proper fuse. Use of a wrong fuse can damage the equipment and may cause fire.

A warning label is attached to the equipment. Do not remove the label. If a label is missing or illegible, contact a FURUNO agent or dealer about replacement.

 WARNING 
To avoid electrical shock, do not remove cover. No user-serviceable parts inside.
 

Name: Warning Label (1)
Type: 86-003-1011-3
Code No.: 100-236-233-10

Safety instructions for the installer

 WARNING	
	<p>Do not open the equipment.</p> <p>Only qualified personnel should work inside the equipment.</p>
	<p>Turn off the power at the main switchboard before beginning the installation.</p> <p>Fire or electrical shock can result if the power is left on.</p>
	<p>Confirm that there is no water leakage at the transducer and temperature sensor.</p> <p>Water leakage can sink the vessel. Also, confirm that neither the transducer or sensor is loosened by vibration. The installer is solely responsible for the installation.</p>
	<p>Confirm that the power supply voltage is within the rating of this equipment.</p> <p>Incorrect voltage will damage the equipment and may cause fire.</p>





 CAUTION					
	<p>The transducer cable must be handled carefully, following the guidelines below.</p> <ul style="list-style-type: none"> • Keep fuels and oils away from the cable. • Locate the cable away from chemicals. • Locate the cable away from locations where it might be damaged. 				
	<p>Do not turn on the power with the transducer exposed to air.</p> <p>Damage to the transducer may result.</p>				
	<p>Observe the following compass safe distances to prevent interference to a magnetic compass:</p> <table border="1" style="margin-left: auto; margin-right: auto;"> <thead> <tr> <th>Standard compass</th> <th>Steering compass</th> </tr> </thead> <tbody> <tr> <td style="text-align: center;">0.30 m</td> <td style="text-align: center;">0.30 m</td> </tr> </tbody> </table>	Standard compass	Steering compass	0.30 m	0.30 m
Standard compass	Steering compass				
0.30 m	0.30 m				

TABLE OF CONTENTS

FOREWORD	v
SYSTEM CONFIGURATION	vi
EQUIPMENT LIST	vii
1. MOUNTING	1
1.1 Bottom Discrimination Sounder.....	1
1.2 Transducer 520-5PSD, 520-5MSD	2
1.2.1 Mounting location.....	2
1.2.2 Acceptable mounting locations	3
1.2.3 Installation Procedure	4
1.3 Transducer 525-5PWD (transom mount).....	5
1.3.1 Installation for flat hulls	5
1.3.2 Installation for deep-V hulls	6
1.3.3 Transducer preparation	6
1.4 Optional Water Temperature Sensor ST950-FJ46-1, ST950-FJ46-2	7
1.5 Optional Triducers	8
1.5.1 Thru-hull triducer	8
1.5.2 Transom route triducer	8
2. WIRING	13
2.1 Connections	13
2.2 Optional Temperature/Speed Sensor, Temperature Sensor	14
2.3 Wiring Optional 1 kW Transducer	15
3. INITIAL SETTINGS, OPERATION.....	16
3.1 MODE SW.....	16
3.2 Operation Check (LED).....	17
4. MAINTENANCE	18
4.1 Maintenance.....	18
4.2 Replacing the fuse	18
APPX. 1 INSTALLATION OF TEMPERATURE SENSORS.....	AP-1
SPECIFICATIONS	SP-1
PACKING LIST	A-1
OUTLINE DRAWING	D-1
INTERCONNECTION DIAGRAM	S-1

FOREWORD

A Word to the Owner of the BBDS1

Congratulations on your choice of the BBSD1 Bottom Discrimination Sounder. We are confident you will see why the FURUNO name has become synonymous with quality and reliability.

Since 1948, FURUNO Electric Company has enjoyed an enviable reputation for innovative and dependable marine electronics equipment. This dedication to excellence is furthered by our extensive global network of agents and dealers.

Your equipment is designed and constructed to meet the rigorous demands of the marine environment. However, no machine can perform its intended function unless properly operated and maintained. Please carefully read and follow the operation and maintenance procedures set forth in this manual.

Thank you for considering and purchasing FURUNO.

We would appreciate feedback from you, the end-user, about whether we are achieving our purposes.

Features:

The BBDS1 features the following:

- Onboard bottom discrimination capability to assist with fishing.
- Displays fish icons which allow the user to easily discern the actual size of fish (ACCU-FISH™).

Operational cautions:

Please keep the following in mind when using the Bottom Discrimination Sounder:

- The BBDS1 is for use with NavNet 3D (MFD8/12/BB), NavNet TZtouch (TZT9/14/BB) and NavNet TZtouch2 (TZTL12F/15F, TZT2BB).
- Use at a depth of 5 m - 100 m.
- Use a ship speed of 10 kt or less.
- Enter the ship's draft value via the NavNet 3D/TZtouch/TZtouch2.

CE/UKCA declaration

With regards to CE/UKCA declarations, please refer to our website (www.furuno.com) for further information about RoHS conformity declarations.

Disclosure of Information about China RoHS

With regards to China RoHS information for our products, please refer to our website (www.furuno.com).

SYSTEM CONFIGURATION

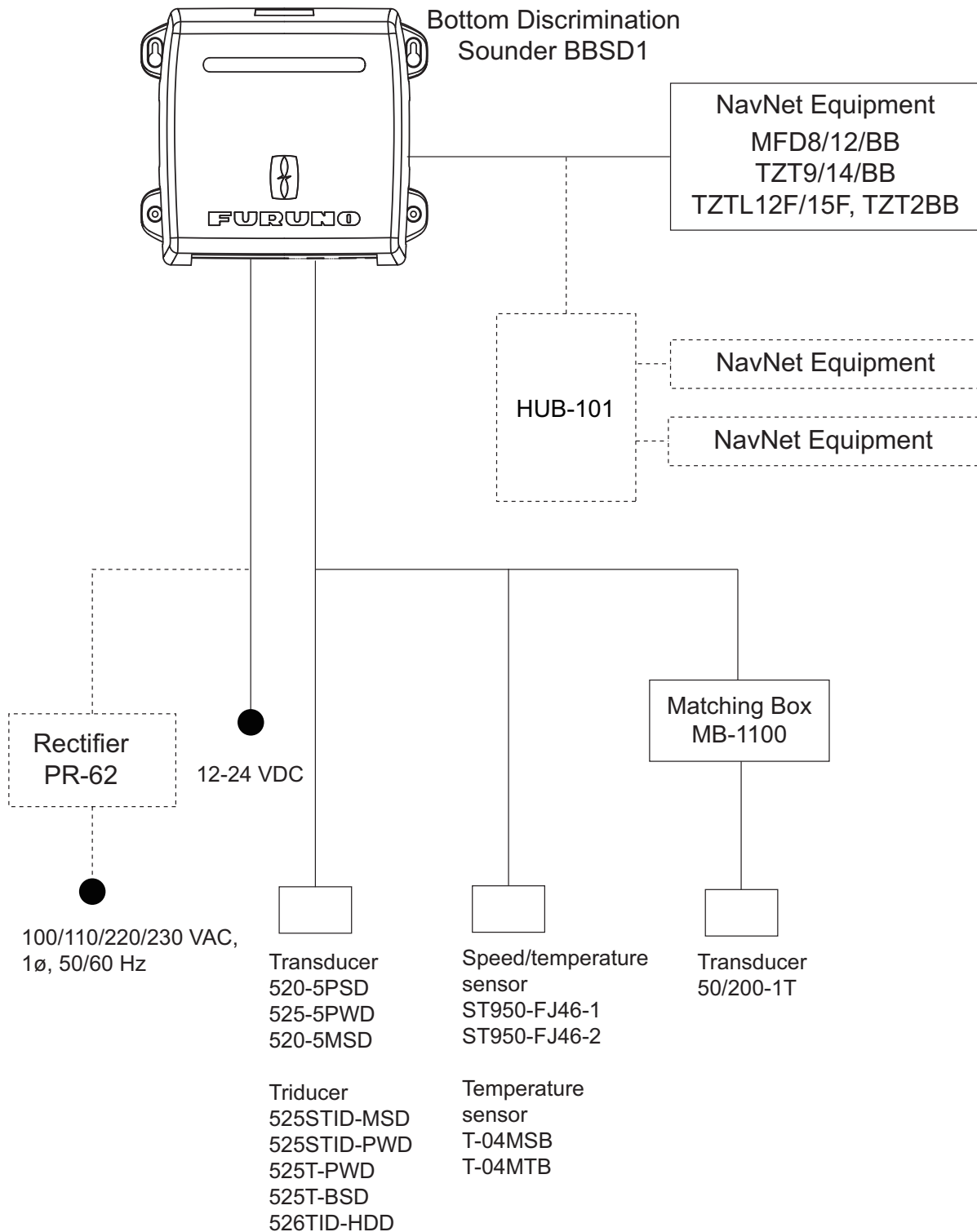

*: HUB-101 may be connected to 3 sets of MFB8/12/MFDBB

EQUIPMENT LIST

Standard supply

Name	Type	Code No.	Qty	Remarks
Bottom Discrimination Sounder	BBDS1	-	1	
Spare Parts	SP02-05201	001-007-860	1 set	Fuse
Installation Materials	CP02-08700	000-017-040	1 set	See Packing List

Optional supply

Name	Type	Code No.	Remarks
Matching Box	MB-1100	000-041-353	For 1 kW
Cable Assy	MOD-Z072-020+	000-167-175-10	2 m LAN cable
	MOD-Z072-100+	000-167-177-10	10 m LAN cable
Triducer	525STID-MSD	000-011-783	Thru-hull mount, metal
	525T-BSD	000-177-685-10	
	526TID-HDD	000-177-689-10	Thru-hull mount, metal, 1 kW MB-1100 is not required.
	525STID-PWD	000-011-784	Transom mount, resin
	525T-PWD	000-177-688-10	
Transducer	520-5PSD	000-015-204	Thru-hull mount, resin
	520-5PWD	000-146-966	Transom mount, resin
	520-5MSD	000-015-212	Thru-hull mount, metal
	50/200-1T	000-015-170	10 m, 1 kW
Speed/ Temperature sensor	ST950-FJ46-1	000-200-363-10	Thru-hull mount, plastic
	ST950-FJ46-2	000-200-364-10	Thru-hull mount, stainless steel
Temperature sensor	T-04MSB	000-026-893	Thru-hull mount
	T-04MTB	000-026-894	Transom mount
Cable Assy.	02S4147	000-141-082	For Speed/Temp sensor, Temp. sensor
Extension Cable*	C332 10M	000-192-786-10	10m, for transducer
Rectifier	PR-62	000-013-484	100 V AC
		000-013-485	110 V AC
		000-013-486	220 V AC
		000-013-487	230 V AC

*: Use of the extension cable may cause the following problems:

- Reduced detection ability
- Wrong ACCU-FISH™ information (fish length smaller than actual length, fewer fish detections, error in individual fish detection).
- Wrong speed data
- No TD-ID recognition

1. MOUNTING

1.1 Bottom Discrimination Sounder

! CAUTION

Do not apply paint, rust protection, etc, to coated surface parts of the unit. These may damage the coated surface areas.

Be especially careful not to apply chemicals to the coated connectors.

The Bottom Discrimination Sounder can be installed on a desktop, deck or on a bulkhead. When selecting a mounting location for the Bottom Discrimination Sounder, keep the following in mind:

- Locate the unit away from areas where rain and splash can occur.
- The temperature and humidity should be moderate and stable.
- Locate the unit away from exhaust pipes and vents.
- Locate the unit where shock and vibration are minimal.
- The mounting location should be well ventilated.
- Keep the unit away from electromagnetic field-generating equipment such as motors and generators.
- Leave slack in cables for maintenance and servicing ease.
- A magnetic compass will be affected if the unit is placed too close to it. Observe the compass safe distances noted in the safety instructions to prevent disturbance to the magnetic compass.
- Fasten the Bottom Discrimination Sounder to the mounting location with four self-tapping screws (4×20, supplied). Fasten as specified by the drawing at the end of this book. If fastening to an upright wall or bulkhead, mount the unit vertically, not sideways.

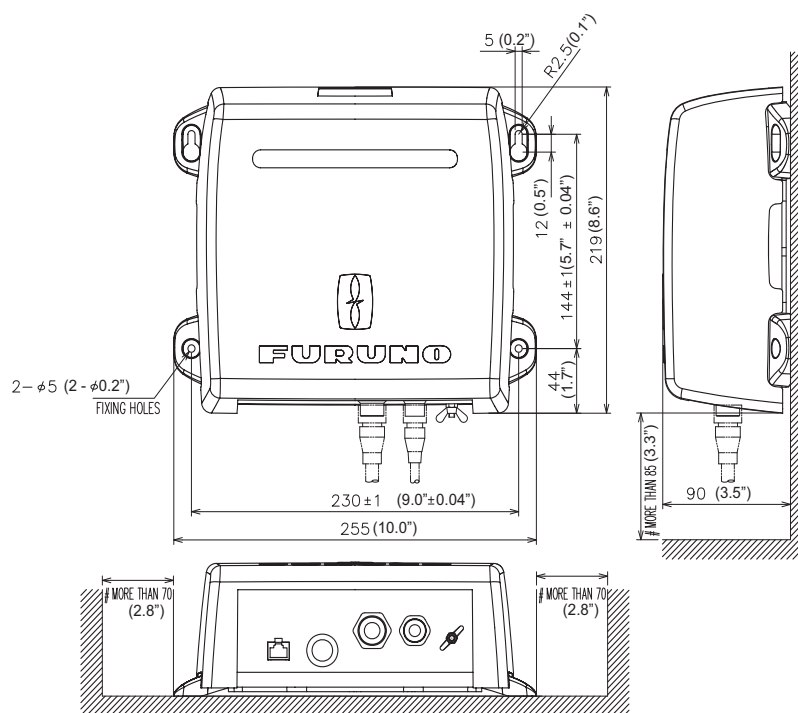

1.2 Transducer 520-5PSD, 520-5MSD

1.2.1 Mounting location

The performance of this sounder is directly related to the mounting location of the transducer, especially for high-speed cruising. The installation should be planned in advance, keeping the standard cable length and the following factors in mind:

- When the boat has a keel, the transducer should be at least 15-30 cm (5.9" - 11.8") away from it. Typical thru-hull mountings are shown in the figure on the next page.
- Air bubbles and turbulence caused by movement of the boat seriously degrade the sounding capability of the transducer. The transducer should, therefore, be located in a position where water flow is the smoothest. Noise from the propellers also adversely affects performance and the transducer should not be mounted nearby. The lifting strakes are notorious for creating acoustic noise, and these must be avoided by keeping the transducer inboard of them.
- The transducer must always remain submerged, even when the boat is rolling, pitching or up on a plane at high speed.
- A practical choice would be somewhere between 1/3 and 1/2 of the boat's length from the stern. For planing hulls, a practical location is generally rather far astern, so that the transducer is always in water regardless of the planing attitude

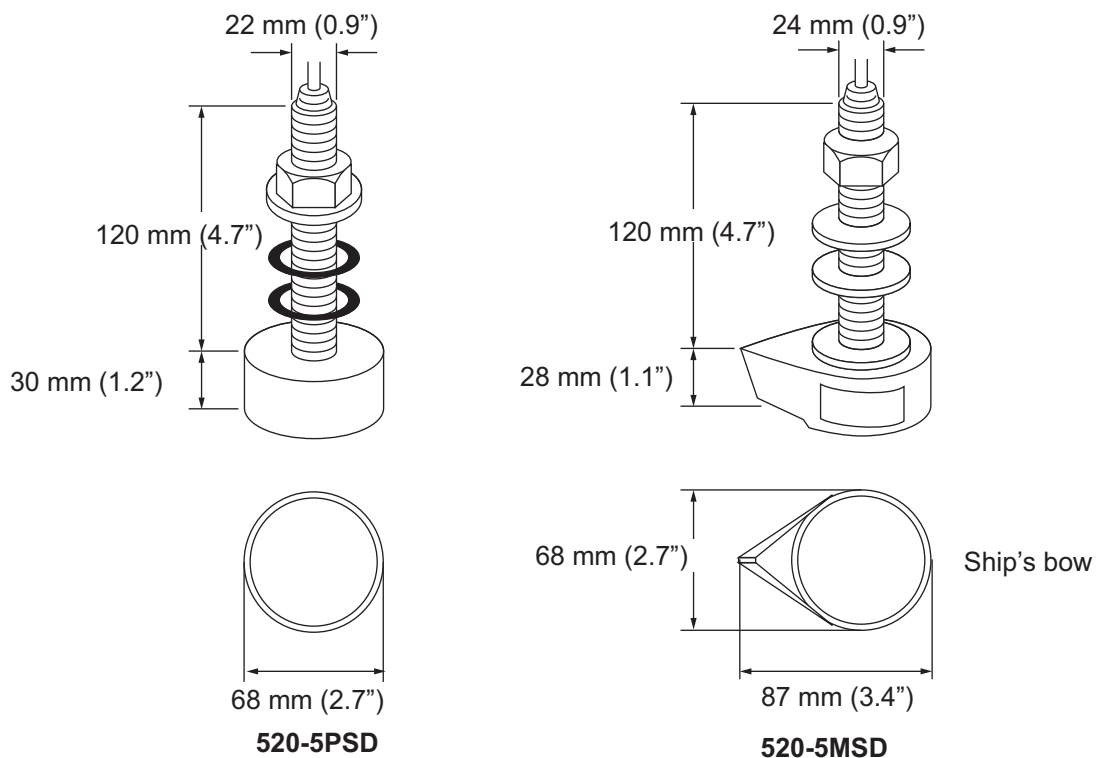

1. MOUNTING

1.2.2 Acceptable mounting locations

Deep V-hull

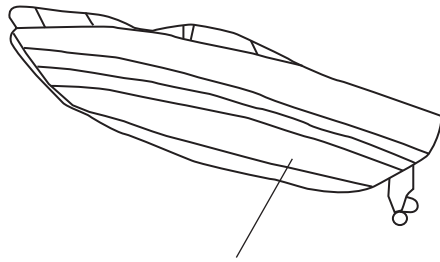

- * Position 1/2 to 1/3 length of the hull from stern.
- * 15-30 cm from keel line (inside first lifting strakes).

High speed V-planning hull

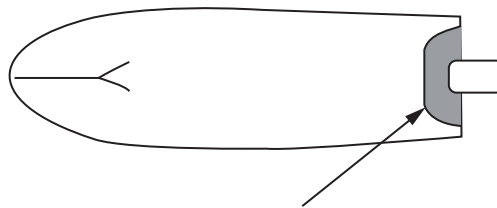
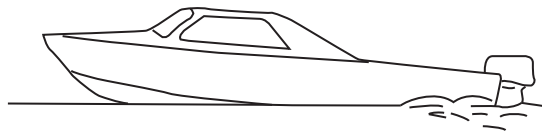

- * Within the submerged bottom area
- * Deadrise angle within 15°

1.2.3 Installation Procedure

1. With the boat hauled out of the water, mark the location selected for mounting the transducer on the bottom of the hull. If the hull is not level within 15 degrees in any direction, fairing blocks made out of teak should be used between the transducer and hull, both inside and outside, to keep the transducer face parallel with the water line. Fabricate the fairing block as shown below and make the entire surface as smooth as possible to provide an undisturbed flow of water around the transducer.

The fairing block should be smaller than the transducer itself to provide a channel to divert turbulent water around the sides of the transducer rather than over its face.

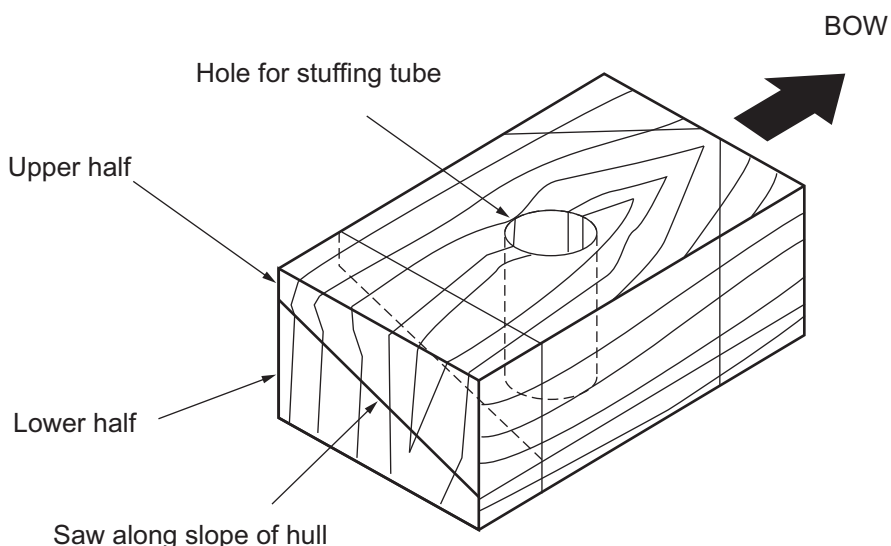

2. Drill a hole just large enough to pass the threaded stuffing tube of the transducer through the hull, making sure it is drilled vertically.
3. Apply a sufficient amount of high quality caulking compound to the top surface of the transducer, around the threads of the stuffing tube and inside the mounting hole (and fairing blocks if used) to ensure watertight mounting.
4. Mount the transducer and fairing blocks and tighten the locking nuts. Be sure that the transducer is properly oriented and its working face is parallel to the water line.

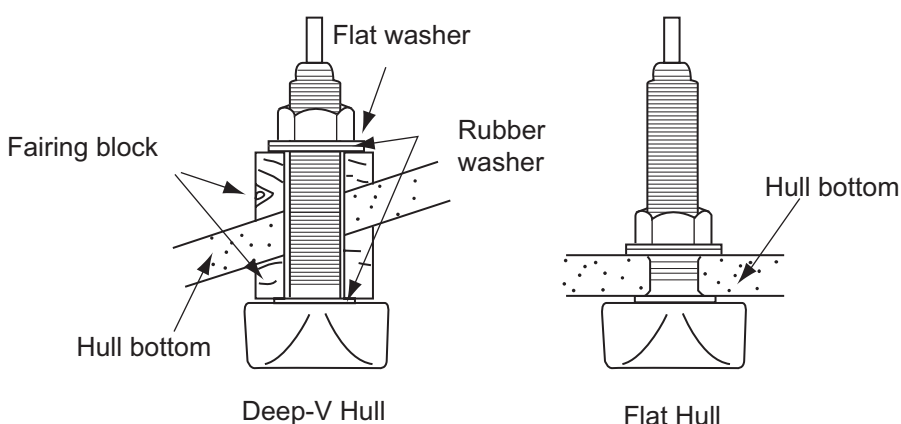

Note: Do not over-stress the stuffing tube and locking nuts through excessive tightening, since the wood block will swell when the boat is placed in the water. It is suggested that the nut be tightened lightly at installation and retightened several days after the boat has been launched.

1. MOUNTING

1.3 Transducer 525-5PWD (transom mount)

This type of mounting is very commonly employed for outboard motor boats. Do not use this method on an inboard motor boat because turbulence is created by the propeller ahead of the transducer.

There are two methods of installation: flush with hull (for flat hulls) and projecting from hull (for deep V-hulls).

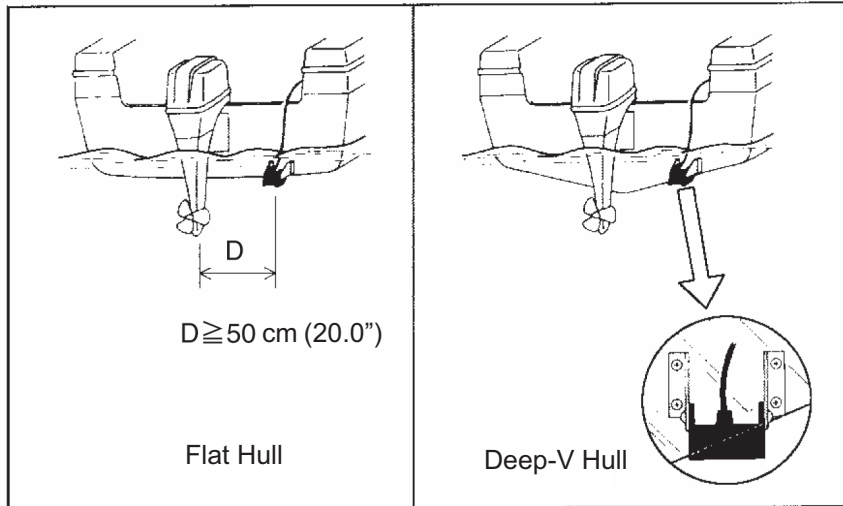

1.3.1 Installation for flat hulls

A suitable mounting location is at least 50 cm (20.0") away from the engine and where the water flow is smooth.

1. Drill four pilot holes in the mounting location.
2. Attach the transducer to the bracket with self-tapping screws (supplied).
3. Adjust the transducer position so the transducer faces right to the seabed.

Note: If necessary, to improve water flow and minimize air bubbles staying on the transducer face, incline the transducer about 5 degrees at the rear. This may require a certain amount of experimentation for fine tuning at high cruising speeds.

4. Fill the gap between the wedge front of the transducer and transom with epoxy material to eliminate any air spaces, and affix tape as shown.

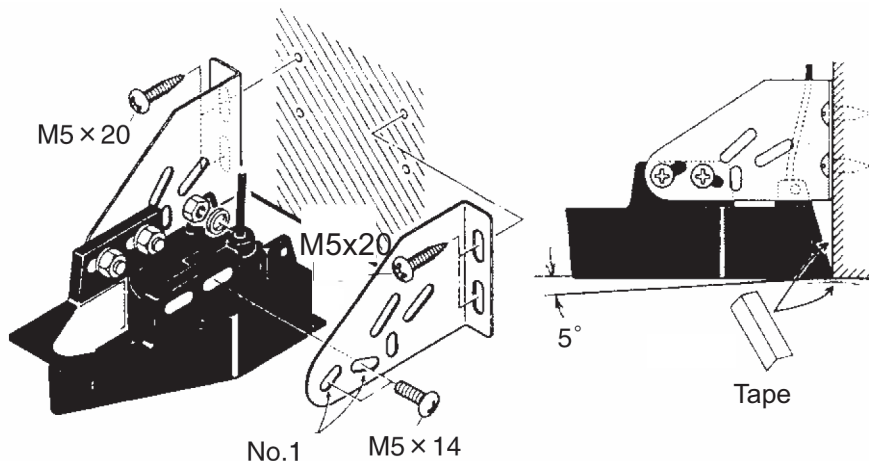

1.3.2 Installation for deep-V hulls

This method is employed on deep-V hulls and provides good performance because the effects of air bubbles are minimal. Install the transducer parallel with water surface; not flush with hull. If the boat is placed on a trailer care must be taken not to damage the transducer when the boat is hauled out of the water and put on the trailer.

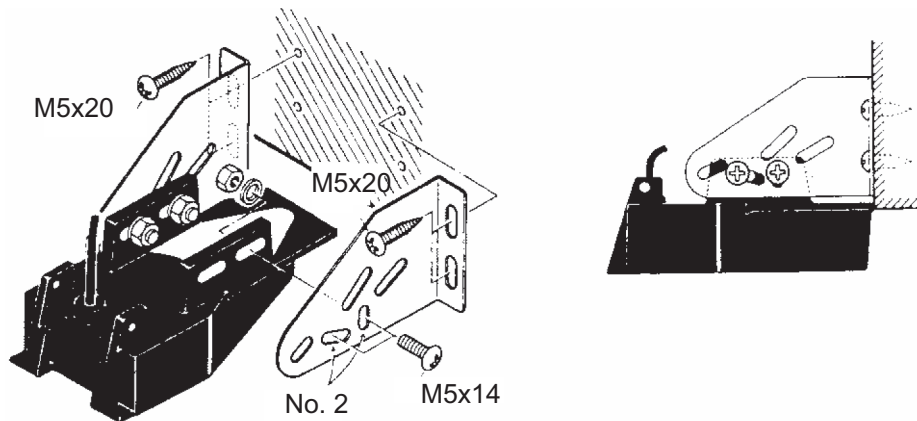

1.3.3 Transducer preparation

Before putting the boat in water, wipe the face of the transducer thoroughly with a detergent liquid soap. This will lessen the time necessary for the transducer to have good contact with the water. Otherwise the time required for complete "saturation" will be longer, and the performance will be reduced.

Note: Do not paint the transducer surface. Performance will be affected.

1. MOUNTING

1.4 Optional Water Temperature Sensor ST950-FJ46-1, ST950-FJ46-2

Select a suitable mounting location considering the following points:

- Select a mid-boat flat position. The sensor does not have to be installed perfectly perpendicular. The sensor must not be damaged in dry-docking operation.
- Select a place apart from equipment generating heat.
- Select a place in the forward direction viewing from the drain hole, to allow for circulation of cooling water.
- Select a place free from vibration.

Procedure

1. Dry-dock the boat.
2. Make a hole of approx. 51 mm (2.0") in diameter in the mounting location.
3. Unfasten locknut and remove the sensor section.
4. Apply high-grade silicone sealant to the flange of the sensor.
5. Pass the sensor casing through the hole.
6. Face the notch on the sensor casing and tighten the locknut.
7. Set the sensor section to the sensor casing and tighten the locknut.
8. Launch the boat and check for water leakage around the sensor.

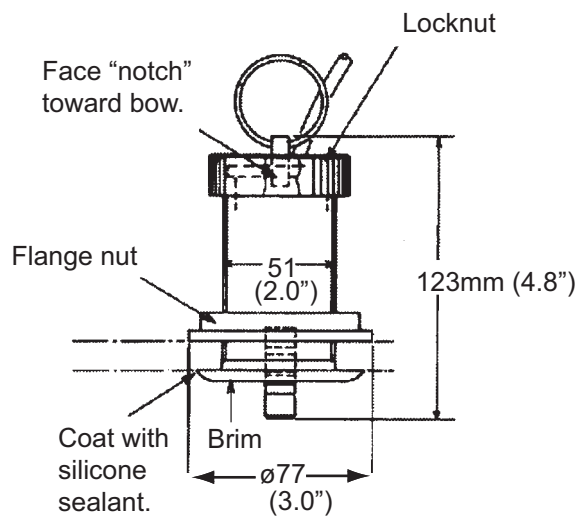

1.5 Optional Triducers

1.5.1 Thru-hull triducer

525STID-MSD

See section 1.4 for how to install the 525STID-MSD.

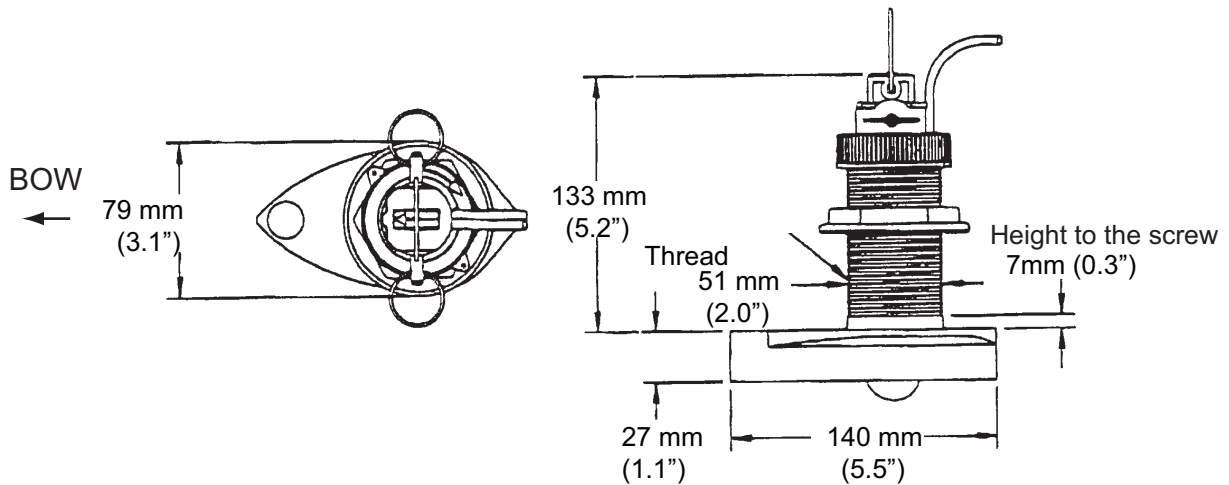

525T-BSD/526TID-HDD

For details of the installation, see the manual of the triducer.

1.5.2 Transom route triducer

525T-BSD/526TID-HDD

For details of the installation, see the manual of the triducer.

525STID-PWD

! CAUTION

Do not install the triducer in the following locations:

- Near any water drain or vent
- Near overhangs, braces, or behind fixtures
- Near any unstable area of the ship's bottom
- Near any areas with peeling paint

Do not install the triducer where it can be a hindrance during any of the following times:

- When pulling a trailer
- When launching
- When being towed
- When ship is in drydock

1. MOUNTING

Mounting location

To ensure the best performance, the sensor must be submerged in aeration-free and turbulence-free water. Mount the sensor close to the centerline of the boat. On slower heavier displacement hulls, positioning it farther from the centerline is acceptable.

Allow adequate space above the bracket for it to release and rotate the sensor upward.

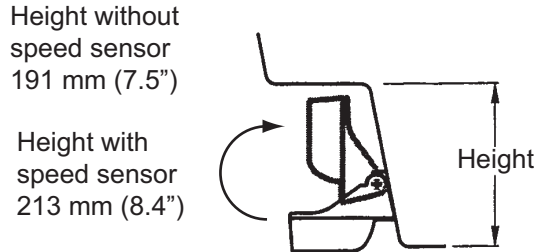

Note 1: Do not mount the sensor in an area of turbulence or bubbles: near water intake or discharge openings; behind strakes, struts, fittings, or hull irregularities; behind eroding paint (an indication of turbulence).

Note 2: Avoid mounting the sensor where the boat may be supported during trailering, launching, hauling, and storage.

Note 3: For single drive boat, mount on the starboard side at least 75 mm (3.0") beyond the swing radius of the propeller.

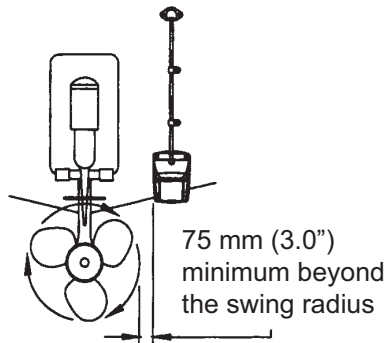

Note 4: For twin drive boat, mount between the drives.

Installation of Bracket

1. Cut out the installation template (enclosed with transducer) along the dotted line.
2. At the selected location, position the template, so the arrow at the bottom is aligned with the bottom edge of the transom. Being sure the template is parallel to the waterline, tape it in place.

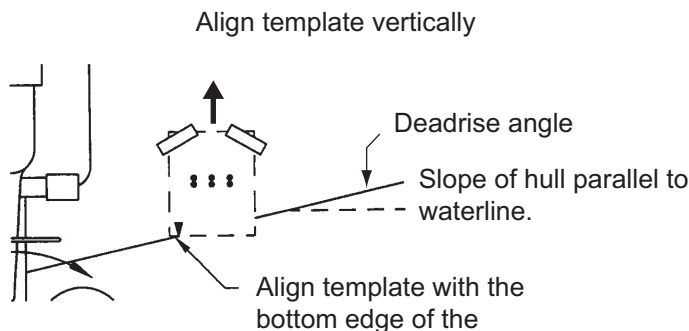

Warning: Always wear safety goggles and a dust mask.

3. Using a 4 mm, #23, or 9/64" bit, drill three holes 22 mm (0.9") deep at the locations indicated. To prevent drilling too deeply, wrap masking tape around the bit 22 mm (0.9") from the point. Fiberglass hull: Minimize surface cracking by chamfering the gelcoat. If a chamfer bit or countersink bit is not available, start drilling with a 6mm or 1/4" bit to a depth of 1 mm (0.04")
4. If you know your transom angle, the bracket is designed for a standard 13° transom angle. **11°-18° angle:** No shim is required. Skip to step 3 in "Adjusting".
Other angles: A shim is required. Skip to step 2 in "Adjusting". If you do not know the transom angle, temporarily attach the bracket and sensor to the transom to determine if the plastic shim is needed.
5. Using the three #10 x 1-1/4" self-tapping screws, temporarily screw the bracket to the hull. DO NOT tighten the screws completely at this time. Follow the step 1-4 in "Attaching the sensor to the bracket", before proceeding with "Adjusting".

Attaching the sensor to the bracket

1. If the retaining cover near the top of the bracket is closed, open it by depressing the latch and rotating the cover downward.

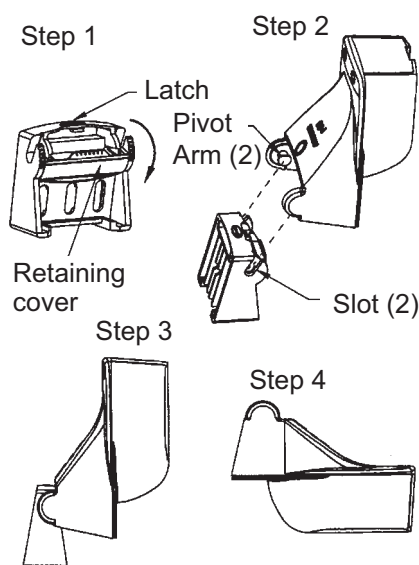

2. Insert the sensor's pivot arms into the slots near the top of the bracket.
3. Maintain pressure until the pivot arms click into place.
4. Rotate the sensor downward until the bottom snaps into the bracket.
5. Close the retaining cover to prevent the accidental release of the sensor when the boat is underway.



Adjusting

1. Using a straight edge, align the underside of the sensor relative to the underside of the hull. The stern of the sensor should be 1-3 mm (1/16-1/8") below the bow of the sensor or parallel to the bottom of the hull.
Note: Do not position the bow of the sensor lower than the stern because aeration will occur.
2. To adjust the sensor's angle relative to the hull, use the tapered plastic shim provided. If the bracket has been temporarily fastened to the transom, remove it. Key the shim in place on the back of the bracket.

1. MOUNTING

2°-10° transom angle (stepped transom and jet boats): Position the shim with the tapered end down.

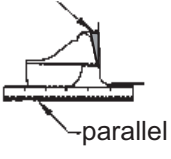
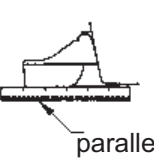
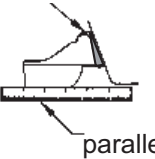
19°-22° transom angle (small aluminum and fiberglass boats): Position the shim with the tapered end up.

2°-10° transom angle	11° transom angle	19°-22° transom angle
Shim with taper up 	No shim 	Shim with taper down 
12°-18° transom angle		
		
Slight angle, no shim		

- If the bracket has been temporarily fastened to the transom, remove it. Apply a marine sealant to the threads of the three #10 x 1-1/4" self-tapping screws to prevent water seeping into the transom. Screw the bracket to the hull. Do not tighten the screws completely at this time.
- Repeat step 1 to ensure that the angle of the sensor is correct.
Note: Do not position the sensor farther into the water than necessary to avoid increasing drag, spray, and water noise and reducing boat speed.
- Using the vertical adjustment space on the bracket slots, slide the sensor up or down to provide a projection of 3 mm (1/8"). Tighten the screws.

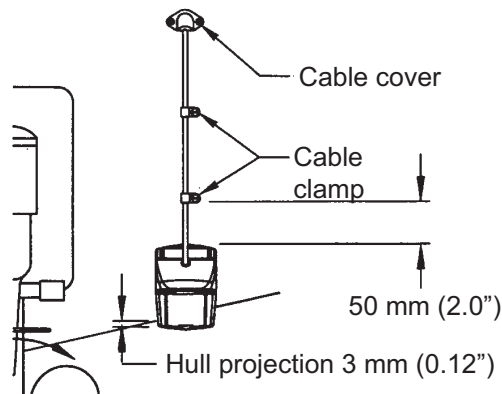

Cable routing

Route the sensor cable over the transom, through a drain hole, or through a new hole drilled in the transom above the waterline.

Never cut the cable or remote the connector; this will void the warranty. Always wear safety goggles and a dust mask.

1. If a hole must be drilled, choose a location well above the waterline. Check for obstructions such as trim tabs, pumps, or wiring inside the hull. Mark the location with a pencil. Drill a hole through the transom using a 19 mm or 3/4" bit (to accommodate the connector).
2. Route the cable over or through the transom.
3. On the outside of the hull secure the cable against the transom using the cable clamps. Position a cable clamp 50 mm (2.0") above the bracket and mark the mounting hole with a pencil.
4. Position the second cable clamp halfway between the first clamp and the cable hole. Mark this mounting hole.
5. If a hole has been drilled in the transom, open the appropriate slot in the transom cable cover. Position the cover over the cable where it enters the hull. Mark the two mounting holes.
6. At each of the marked locations, use a 3 mm or 1/8" bit to drill a hole 10 mm (0.4") deep. To prevent drilling too deeply, wrap masking tape around the bit 10 mm (0.4") from the point.
7. Apply marine sealant to the threads of the #6 x 1/2" self-tapping screw to prevent water from seeping into the transom. If you have drilled a hole through the transom, apply marine sealant to the space around the cable where it passes through the transom.
8. Position the two cable clamps and fasten them in place. If used, push the cable cover over the cable and screw it in place.
9. Route the cable to the instrument being careful not to tear the cable jacket when passing it through the bulkhead(s) and other parts of the boat. To reduce electrical interference, separate the sensor cable from other electrical wiring and "noise" sources. Coil any excess cable and secure it in place with zip-ties to prevent damage.

2. WIRING

2.1 Connections

Connect the NavNet equipment, power cable and transducer cable as shown in the figure below.

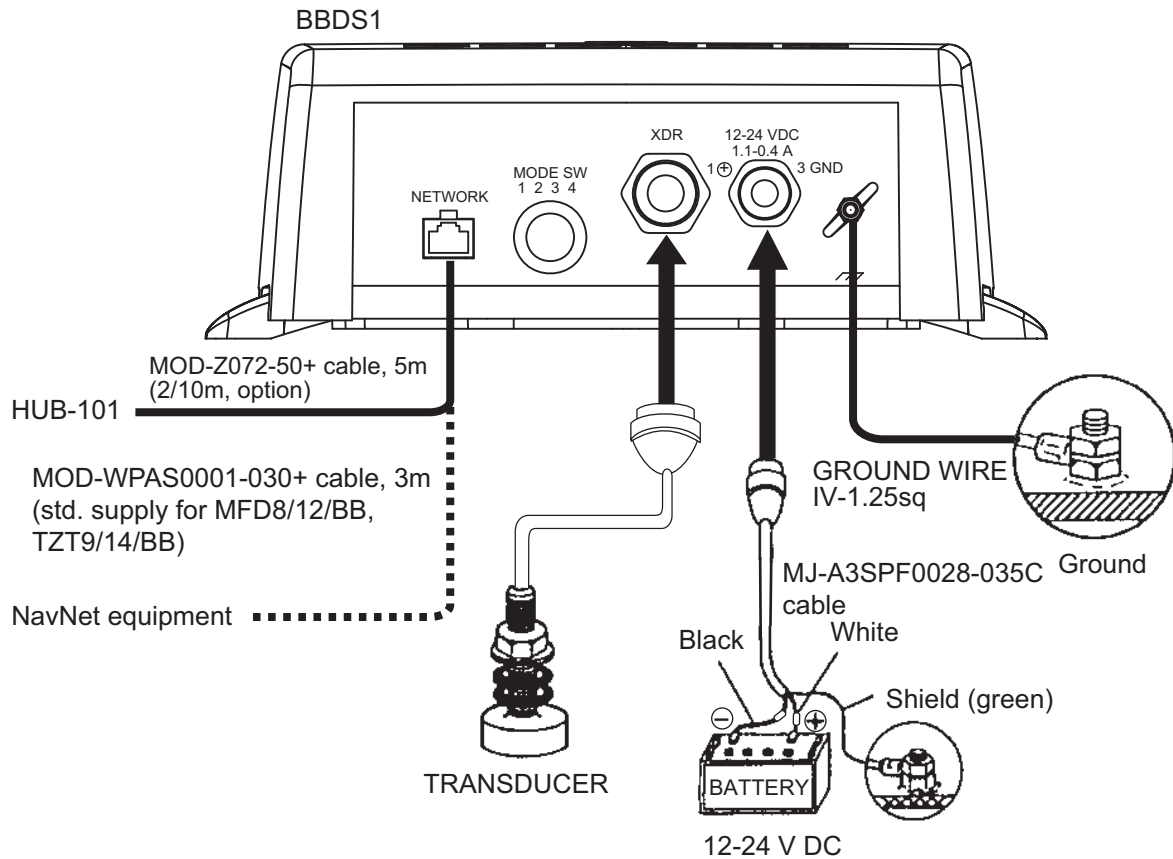

Ground

Connect the ground wire (1.25sq) to ship's ground to prevent interference to the picture. Shorten the ground wire as much as possible. For FRP vessels, install a ground plate that measures about 20 cm by 30 cm (8" x 12") on the outside of the hull bottom to provide a ground point.

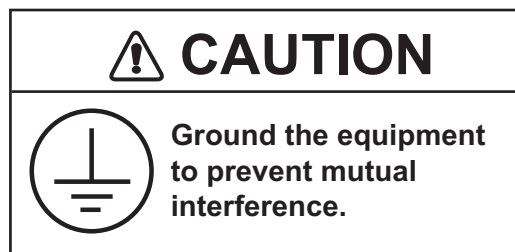

Note: Use a "closed-type" lug  to make the ground connection at the Bottom Discrimination Sounder.

External KP

Consult with your dealer if connection of an external KP is required to reduce interference from another transducer.

2.2 Optional Temperature/Speed Sensor, Temperature Sensor

Connect the temperature/speed sensor or temperature sensor to the XDR port with the cable asy. (Type: 02S4147, Code No.: 000-141-082, option).

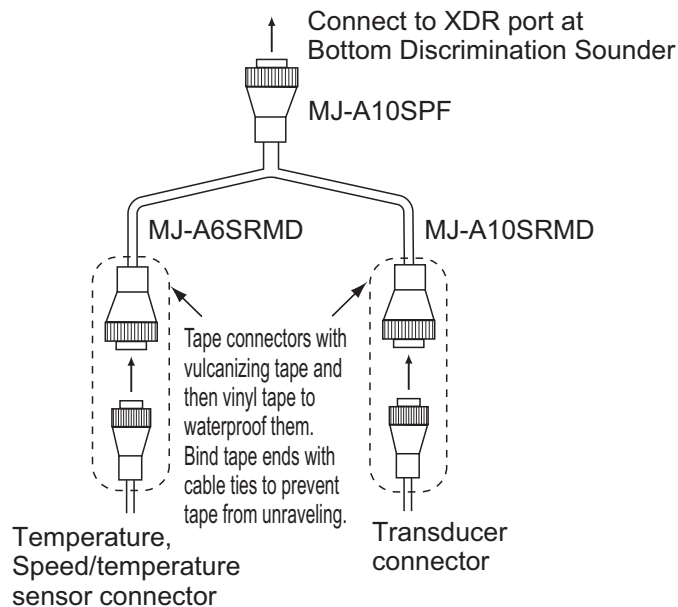
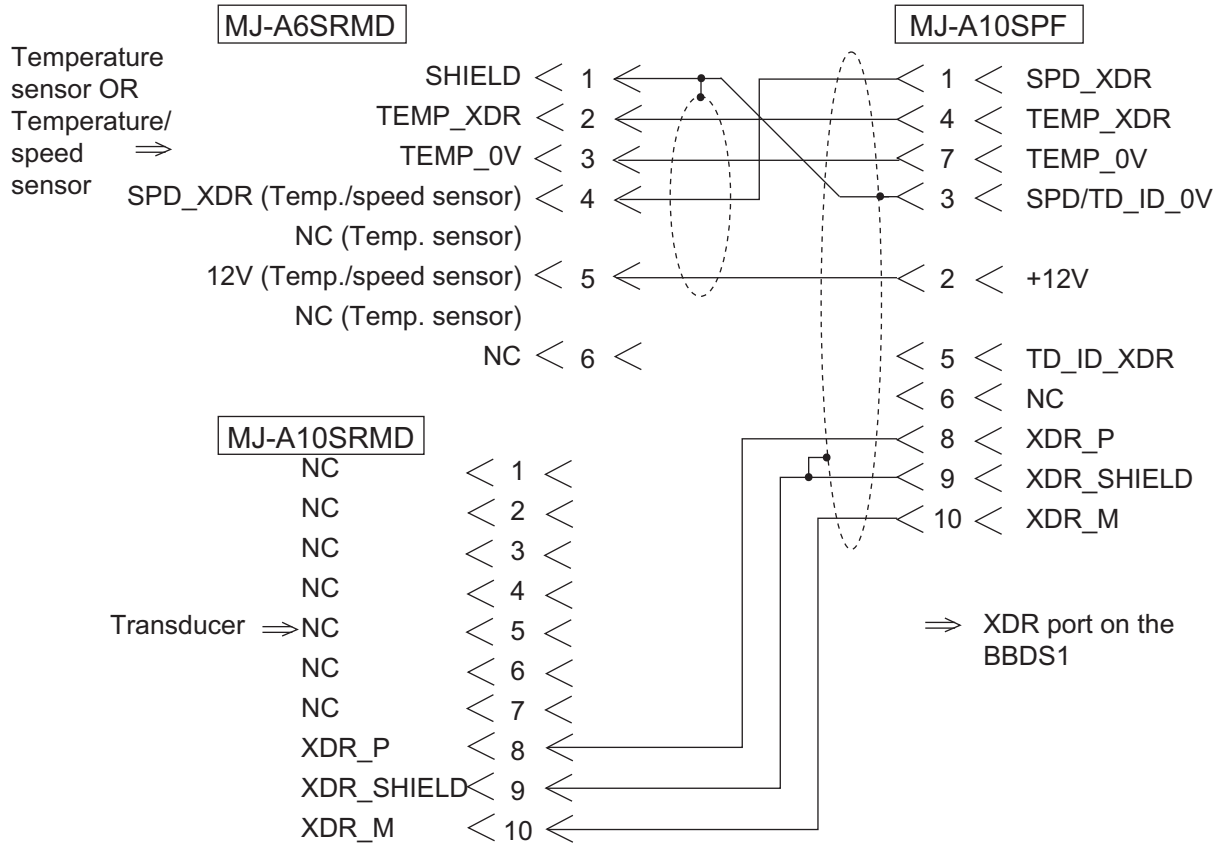

2.3 Wiring Optional 1 kW Transducer

To connect optional transducer 50/200-1T, the optional Matching Box MB-1100 is required.

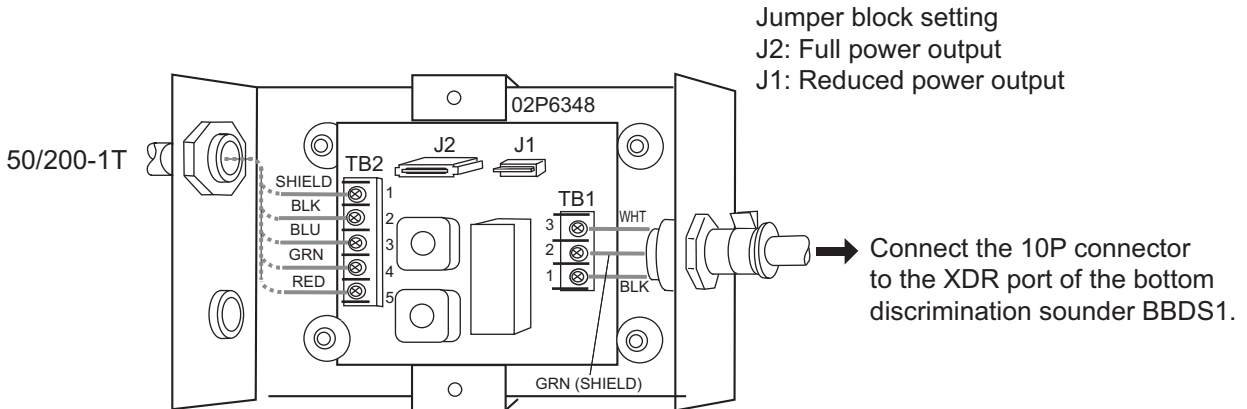

Matching Box: Type MB-1100. Code Number 000-041-353

Name	Type	Code no.	Qty	Remarks
Matching Box	MB-1100	000-041-000	1	Cable w/10P connector supplied for connection to Bottom Discrimination Sounder.
Crimp-on Lug	FV1.25-3 Red	000-166-756-10	6	1 spare supplied
Cord Lock	NC-1	000-168-230-10	1	For use with separate transducer. Do not use.

Fabrication of transducer cable

Fabricate the transducer cable as illustrated below to connect it to the Matching Box.

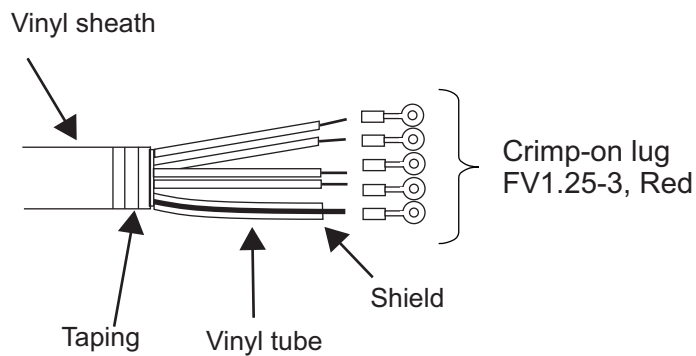

3. INITIAL SETTINGS, OPERATION

After connecting the NavNet equipment, select the transmission power from the NavNet equipment startup wizard. Refer to the respective Instruction Manual.

3.1 MODE SW

The MODE switch provides the functions described in the table below. Remove the rubber cap to access the switch and set switches with a plastic screwdriver or the like.

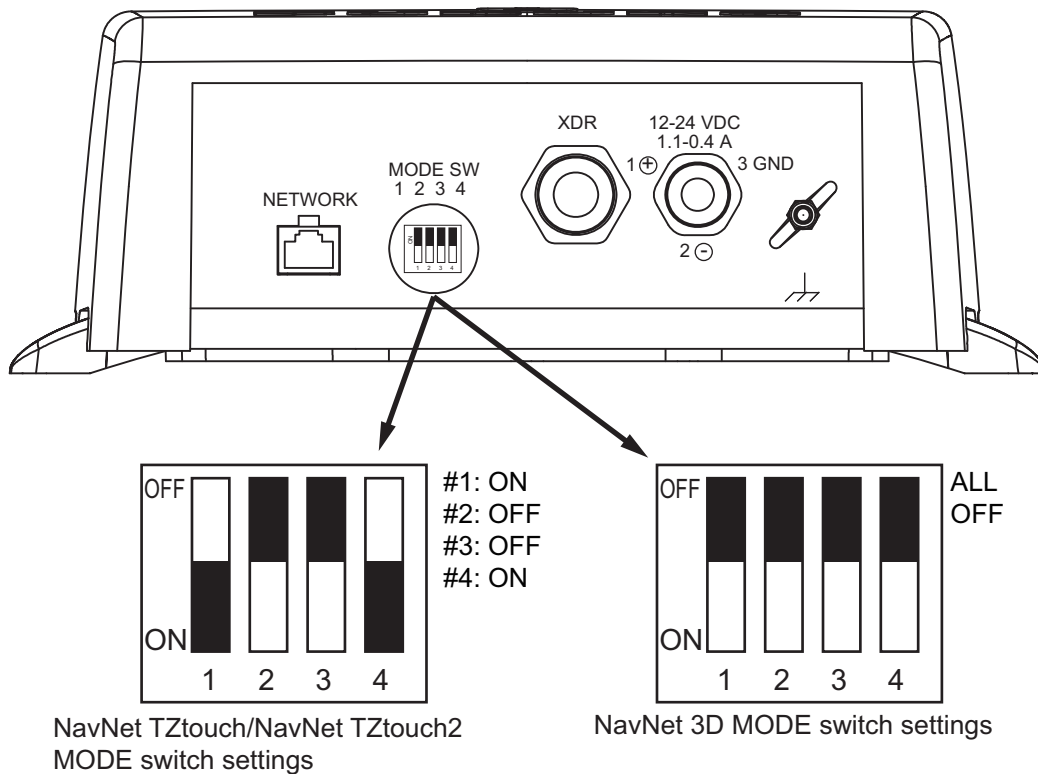

SW No.	Function, description	Setting content
1 (Default: ON)	Power from Navnet equipment	OFF: Sounder powered on/off by NavNet equipment. ON: Sounder not powered on/off by Navnet equipment.
2 (Default: OFF)	IP number (Currently no use)	OFF: IP0 ON: IP1 Note: When installing the below-mentioned units to a NavNet network other than the NavNet 3D network, turn the 1st unit OFF and the 2nd unit ON. <ul style="list-style-type: none"> • BBDS1, 2 units • DFF1, 2 units • BBDS1, 1 unit, DFF1, 1 unit (total of 2 units)
3 (Default: OFF)	Factory testing	OFF: Testing OFF ON: Testing ON
4 (Default: ON)	Automatic IP setting (Currently no use)	OFF: Automatic IP enabled ON: Automatic IP disabled

For NavNet 3D, turn off all switches.

3.2 Operation Check (LED)

The BBDS1 is powered on and off according to the NavNet series it is connected to:

NavNet TZtouch/TZtouch2: Powered on and off from the mains switchboard.

NavNet 3D: Powered on and off from a display unit.

The LED on the Bottom Discrimination Sounder lights or flashes according to equipment state, as described in the table below.

LED state	Meaning
Lit continuously	NavNet equipment is not showing the sounder display, or sounder is not connected to NavNet equipment.
Flashing every two seconds	Normal operation
Flashing every four seconds	Factory test mode

* The LED lights for approximately 20 seconds after turning on the power while the equipment is being initialized.

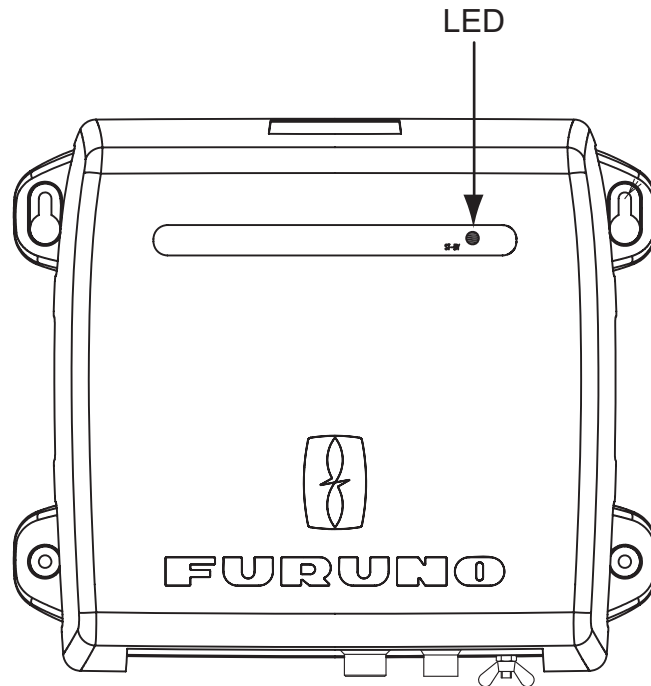

4. MAINTENANCE

WARNING

Do not open the equipment unless totally familiar with electrical circuits and service manual.

Only qualified personnel should work inside the equipment.

4.1 Maintenance

Regular maintenance is essential for good performance. Check the items listed in the table below monthly to help keep your equipment in good shape for years to come.

Item	Action	Performance Schedule
Transducer cable	Check that cable is tightly fastened and is not damaged. Replace if damaged.	Once a month
Power cable, transducer cable plus	Check that they are tightly fastened and not damaged. Refasten if necessary. Replace if damaged.	Once a month
Ground	Check for corrosion. Clean if necessary.	Once a month
Power supply voltage	Check voltage. If out of rating correct problem.	Once a month
Cleaning the Bottom Discrimination Sounder's cabinet	Dust or dirt on the cabinet may be removed with a dry cloth. Do not use chemical-based cleaners to clean the cabinet; they can remove paint and markings.	Once a month
Transducer	Marine life on the transducer face will result in a gradual decrease in sensitivity. Check the transducer face for cleanliness each time the boat is dry-docked. Carefully remove any marine life with a piece of wood or fine-grade sandpaper.	Every time boat is dry docked

4.2 Replacing the fuse

The two 3 A fuses (Type: FGBO-A 125V 3A PBF, Code No. 000-155-850-10) in the snap-in fuse holder on the power cable protect the equipment from equipment fault and reverse polarity of the ship's mains. If the equipment cannot be powered, a fuse may have blown. Find out the cause for blown fuse before replacing a fuse. If a fuse blows again after replacement, contact a FURUNO agent or dealer for advice.

WARNING

Use the proper fuse.

Use of a wrong fuse can result in damage to the equipment or cause fire.

APPX. 1 INSTALLATION OF TEMPERATURE SENSORS

The installation instructions in this chapter are copied from the manufacturer's (AIRMAR Technology Corporation) installation guide, which is included with your sensor.

The model numbers mentioned within the documentation should be read as follows:

T42 => T-04MSB

T80 => T-04MTB

OWNER'S GUIDE & INSTALLATION INSTRUCTIONS

Thru-Hull, Analog High-Precision Temperature Sensor

Model T42

05/28/14

17-437-02, rev. 01

Follow the precautions below for optimal product performance and to reduce the risk of property damage, personal injury, and/or death.

WARNING: Always wear safety goggles and a dust mask when installing.

WARNING: Immediately check for leaks when the boat is placed in the water. Do not leave the boat unchecked for more than three hours. Even a small leak can allow considerable water to accumulate.

CAUTION: Never install a bronze sensor in a metal hull because electrolytic corrosion will occur.

CAUTION: Never install a metal sensor on a vessel with a positive ground system.

CAUTION: Never pull, carry, or hold the sensor by its cable; this may sever internal connections.

CAUTION: Never use solvents. Cleaner, fuel, sealant, paint, and other products may contain solvents that can damage plastic parts, especially the sensor's face.

IMPORTANT: Read the instructions completely before proceeding with the installation. These instructions supersede any other instructions in your instrument manual if they differ.

Applications

- Bronze sensor recommended for fiberglass or wood hull only.
- The hull must be a minimum of 8mm (5/16") thick at the mounting location.

Mounting Location

Choose a location where the temperature sensor will be in contact with the water at all times.

Record the information found on the cable tag for future reference.

Part No. _____ Date _____

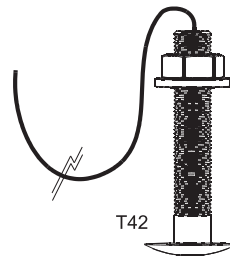

Tools & Materials

- Safety goggles
- Dust mask
- Electric drill
- Drill bit/hole saw/spade bit:
 - Pilot hole 3mm or 1/8"
 - T42 22mm or 7/8"
- Sandpaper
- Mild household detergent or weak solvent (alcohol)
- Marine sealant (suitable for below waterline)
- Slip-joint pliers
- Installation in a cored fiberglass hull (see page 2)
 - Hole saw for hull interior: 30mm or 1-1/4"
 - Cylinder, wax, tape, and casting epoxy
- Water-based anti-fouling paint (**mandatory in salt water**)

Sensor Installation

Hole Drilling

Cored fiberglass hull — Follow separate instructions on page 2.

1. Drill a 3mm or 1/8" pilot hole from inside the hull. If there is a rib, strut, or other hull irregularity near the selected mounting location, drill from the outside.
2. Using the appropriate drill bit, cut a hole perpendicular to the hull from outside the boat.
3. Sand and clean the area around the hole, inside and outside, to ensure that the marine sealant will adhere properly to the hull. If there is any petroleum residue inside the hull, remove it with either mild household detergent or a weak solvent (alcohol) before sanding.

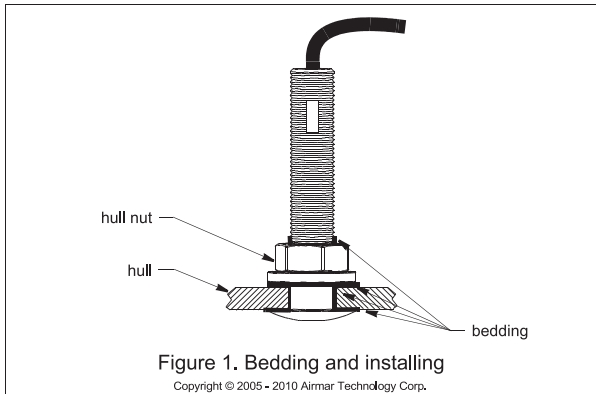

Bedding

CAUTION: Be sure all surfaces to be bedded are clean and dry.

1. Remove the hull nut (see Figure 1).
2. Apply a 2 mm (1/16") thick layer of marine sealant around the flange of the sensor that will contact the hull and up the stem. The sealant must extend 6mm (1/4") higher than the combined thickness of the hull and the hull nut. This will ensure that there is marine sealant in the threads to seal the hull and hold the hull nut securely in place.
3. Apply a 2 mm (1/16") thick layer of marine sealant to the flange of the hull nut that will contact the hull.

Installing

1. From outside the hull, thread the cable through the mounting hole.
2. Push the sensor into the mounting hole using a twisting motion to squeeze out excess marine sealant (see Figure 1).
3. From inside the hull, slide the hull nut onto the cable. Screw the hull nut in place. Tighten it with slip-joint pliers.
Cored fiberglass hull—Do not over tighten, crushing the hull.
Wood hull—Allow for the wood to swell before tightening.
4. Remove any excess marine sealant on the outside of the hull to ensure smooth water flow over the sensor.

Checking for Leaks

When the boat is placed in the water, **immediately** check around the thru-hull sensor for leaks. Note that very small leaks may not be readily observed. Do not leave the boat in the water for more than 3 hours before checking it again. If there is a small leak, there may be considerable bilge water accumulation after 24 hours. If a leak is observed, repeat "Bedding" and "Installing" **immediately** (see page 2).

Cable Routing & Connecting

CAUTION: If the sensor came with a connector, do not remove it to ease cable routing. If the cable must be cut and spliced, use Airmar's splash-proof Junction Box No. 33-035 and follow the instructions supplied. Removing the waterproof connector or cutting the cable, except when using a water-tight junction box, will void the sensor warranty.

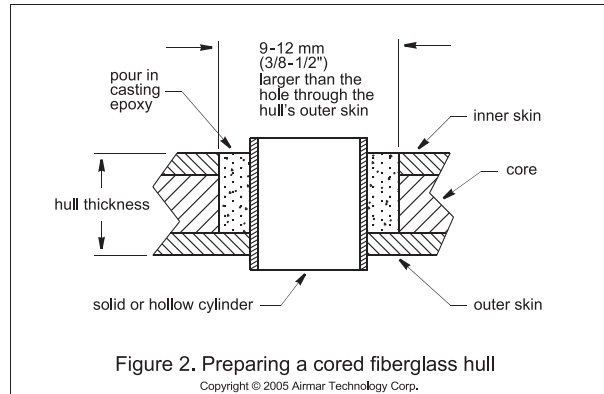

1. Route the cable to the instrument being careful not to tear the cable jacket when passing it through the bulkhead(s) and other parts of the boat. Use grommet(s) to prevent chafing. To reduce electrical interference, separate the transducer cable from other electrical wiring and the engine. Coil any excess cable and secure it in place with cable ties to prevent damage.
2. Refer to the instrument owner's manual to connect the transducer to the instrument.

Installation in a Cored Fiberglass Hull

The core (wood or foam) must be cut and sealed carefully. The core must be protected from water seepage, and the hull must be reinforced to prevent it from crushing under the hull nut allowing the sensor to become loose.

CAUTION: Completely seal the hull to prevent water seepage into the core.

1. Drill a 3mm or 1/8" pilot hole from inside the hull. If there is a rib, strut, or other hull irregularity near the selected mounting location, drill from the outside. (If the hole is drilled in the wrong location, drill a second hole in a better location. Apply masking tape to the outside of the hull over the incorrect hole and fill it with epoxy.)
2. Using the 21 mm or 7/8" drill bit, cut a hole from outside the hull through the *outer skin* only (see Figure 2).
3. From inside the hull using the 30mm or 1-1/4" hole saw, cut through the *inner skin* and most of the core. The core material can be very soft. Apply only light pressure to the hole saw after cutting through the inner skin to avoid accidentally cutting the *outer skin*.
4. Remove the plug of core material so the *inside* of the outer skin and the inner core of the hull is fully exposed. Clean and sand the inner skin, core, and the outer skin around the hole.
5. Coat a hollow or solid cylinder of the correct diameter with wax and tape it in place. Fill the gap between the cylinder and hull with casting epoxy. After the epoxy has set, remove the cylinder.
6. Sand and clean the area around the hole, inside and outside, to ensure that the sealant will adhere properly to the hull. If there is any petroleum residue inside the hull, remove it with either mild household detergent or a weak solvent (alcohol) before sanding.
7. Proceed with "Bedding" and "Installing" (see page 2).

OWNER'S GUIDE & INSTALLATION INSTRUCTIONS

Surface Mount, Analog

Temperature Sensor

Model T80

Record the information found on the cable tag for future reference.

Part No. _____ Date _____

T80



05/28/14

17-5684-01 rev. 01

Follow the precautions below for optimal product performance and to reduce the risk of property damage, personal injury, and/or death.

WARNING: Always wear safety goggles and a dust mask when installing.

WARNING: Below the waterline mount—When the boat is placed in the water, immediately check for leaks around the screws and any other holes drilled in the hull.

CAUTION: Installation on a metal hull—The stainless steel housing must be isolated from a metal hull to prevent electrolytic corrosion. Use marine sealant.

CAUTION: Never install a metal sensor on a vessel with a positive ground system.

IMPORTANT: Read the instructions completely before proceeding with the installation. These instructions supersede any other instructions in your instrument manual if they differ.

Applications

- Measures air or water temperature.
- Stainless steel sensor is compatible with all hull materials. Recommended for aluminum hulls to prevent electrolytic corrosion, provided the stainless steel sensor is isolated from the metal hull by using marine sealant.

Mounting Location

The sensor can be mounted anywhere that you want to know the temperature. For example, you can mount the sensor on the transom, in the live well, or in the engine compartment.

If you are measuring water temperature, choose a location where the sensor will be in contact with the water at all times.

Tools & Materials

Safety goggles
 Dust mask
 Pencil
 Electric drill
 Drill bit/hole saw/spade bit:
 Pilot holes 3 mm or 1/8"
 Transom hole (some installations) 18 mm or 3/4"
 2 Stainless steel, self-tapping screws 4 x 18 mm or #8 x 3/4"
 Marine sealant (suitable for below waterline)
 Screwdriver(s)
 Cable clamp(s) (some installations)
 Grommet(s) (some installations)
 Cable ties

Installation

Mounting on the transom

CAUTION: Mount the sensor as close to the centerline (keel) of the boat as possible to ensure the sensor remains in the water when the boat is turning (see Figure1).

CAUTION: Fiberglass hull—Minimize surface cracking by running the drill in reverse until the gelcoat is penetrated.

CAUTION: If the sensor came with a connector, do not remove it to ease cable routing. If the cable must be cut and spliced, use Airmar's splash-proof Junction Box No. 33-035 and follow the instructions provided. Removing the waterproof connector or cutting the cable, except when using a water-tight junction box, will void the sensor warranty.

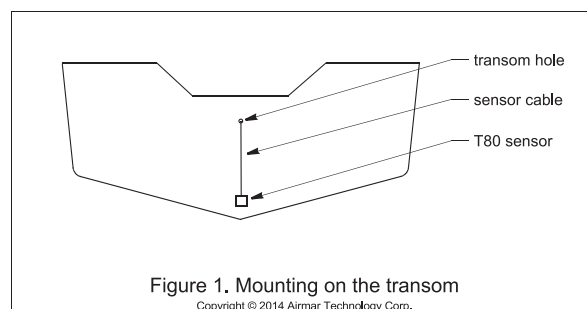

Figure 1. Mounting on the transom

Copyright © 2014 Airmar Technology Corp.

APPX. 1 INSTALLATION OF TEMPERATURE SENSORS

Mount the sensor near the centerline and close to the bottom of the transom.

Route the sensor cable over the transom, through a drain hole, or through a hole that you have drilled in the transom **above the waterline**.

1. Place the sensor against the hull and mark the position of the screw holes with a pencil.
2. Using a 3mm or 1/8" drill bit, drill pilot holes at the marked locations, 10mm (3/8") deep.
3. Apply marine sealant to the threads of the purchased screws to prevent water from seeping into the transom.
4. Screw the temperature sensor to the hull.
5. If a hole must be drilled through the transom, choose a location **well above the waterline**. Check for obstructions such as trim tabs, pumps, or wiring inside the hull. Mark the location with a pencil. Drill a hole through the transom using the appropriate size hole saw or spade bit (to accommodate the connector). Do NOT remove the connector.
6. Route the cable over or through the transom.
7. On the outside of the hull, secure the cable against the transom using a purchased cable clamp(s). Mark the position of the screw hole(s) with a pencil.
8. Using a 3mm or 1/8" drill bit, drill a pilot hole(s) at the marked locations, 10mm (3/8") deep.
9. Apply marine sealant to the threads of the screw(s) to prevent water from seeping into the transom.
10. Fasten the cable clamp(s) in place.
11. If a hole has been drilled through the transom, apply marine sealant to the space around the cable leading through the transom.

Cable Routing & Connecting

1. Route the cable to the instrument, being careful not to tear the cable jacket when passing it through the bulkhead(s) and other parts of the boat. To reduce electrical interference, separate the sensor cable from other electrical wiring and sources of noise. Coil any excess cable and secure it in place with cable ties to prevent damage.
2. Refer to the instrument owner's manual to connect the sensor to the instrument.

Replacement Sensor & Parts

The information needed to order a replacement sensor is printed on the cable tag. Do not remove this tag. When ordering, specify the part number and date. For convenient reference, record this information at the top of page one.

Obtain parts from your instrument manufacturer or marine dealer.

Gemeco (USA)	Tel: 803-693-0777 Fax: 803-693-0477 email: sales@gemeco.com
Airmar EMEA (Europe, Middle East, Africa)	Tel: +33,(0)2.23.52.06.48 Fax: +33,(0)2.23.52.06.49 email: sales@airmar-emea.com



35 Meadowbrook Drive, Milford, New Hampshire 03055-4613, USA
•www.airmar.com

SPECIFICATIONS OF BOTTOM DISCRIMINATION SOUNDER BBDS1

1 GENERAL

- 1.1 Output power 600 W/ 1 kW rms nominal
- 1.2 TX frequency 50 kHz or 200 kHz, 50/200 kHz alternating
- 1.3 Amplifier type Wide dynamic linear amp (double superheterodyne)
- 1.4 Measuring function Fish length measurement, Bottom discrimination,
Heave compensation*, Frequency auto-setting from transducer-ID
data (specified transducer)
*: optional sensor required
- 1.5 Network protocol Ethernet 100BASE-TX
- 1.6 Depth range and Pulse Repetition Rate

Range (m)	PRR (/min.)
2	3000
5	3000
10	1990
40	485
100	195
200	95
400	65
1200	34

2 POWER SUPPLY

12-24 VDC: 1.1-0.4 A (at 1 kW output)

3 ENVIRONMENTAL CONDITION

- 3.1 Ambient temperature -15°C to +55°C
- 3.2 Relative humidity 93% at 40°C
- 3.3 Degree of protection IP20
- 3.4 Vibration IEC 60945-4

4 UNIT COLOR

N3.0

P A C K I N G L I S T

02GH-X-9851 -4 1/1

BBDS1-J/E

A-1

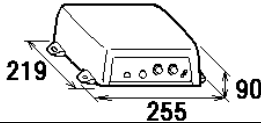
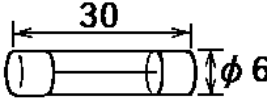
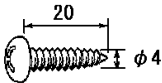
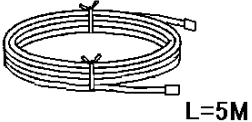
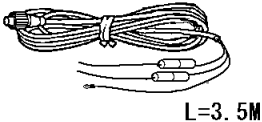
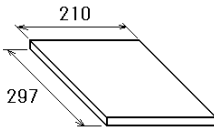
N A M E	O U T L I N E	DESCRIPTION/CODE No.	Q' TY
ユニット UNIT			
底質判別魚探 BOTTOM DISCRIMINATION SOUNDER		BBDS1 000-017-039-00	1
予備品 SPARE PARTS SP02-05201			
ヒューズ GLASS TUBE FUSE		FGBO-A 125V 3A PBF 000-155-850-10	2
工事材料 INSTALLATION MATERIALS CP02-08700			
+トラスタツピンネジ 1シユ SELF-TAPPING SCREW		4X20 SUS304 000-158-850-10	4
ケーブル(組品)LAN LAN CABLE ASSEMBLY		MOD-Z072-050+ 001-167-890-10	1
ケーブル組品MJ POWER CABLE ASSY.		MJ-A3SPF0028-035C 000-164-952-10	1
図書 DOCUMENT			
取扱説明書 OPERATOR'S MANUAL		OM*-20380-* 000-173-390-1* **	1

コード番号末尾の[**]は、選択品の代表コードを表します。

CODE NUMBER ENDING WITH "**" INDICATES THE CODE NUMBER OF REPRESENTATIVE MATERIAL.

(略図の寸法は、参考値です。DIMENSIONS IN DRAWING FOR REFERENCE ONLY.)

C2038-Z01-E

表 1 TABLE 1

寸法区分 (mm) DIMENSION	公差 (mm) TOLERANCE
$L \leq 50$	± 1.5
$50 < L \leq 100$	± 2.5
$100 < L \leq 500$	± 3

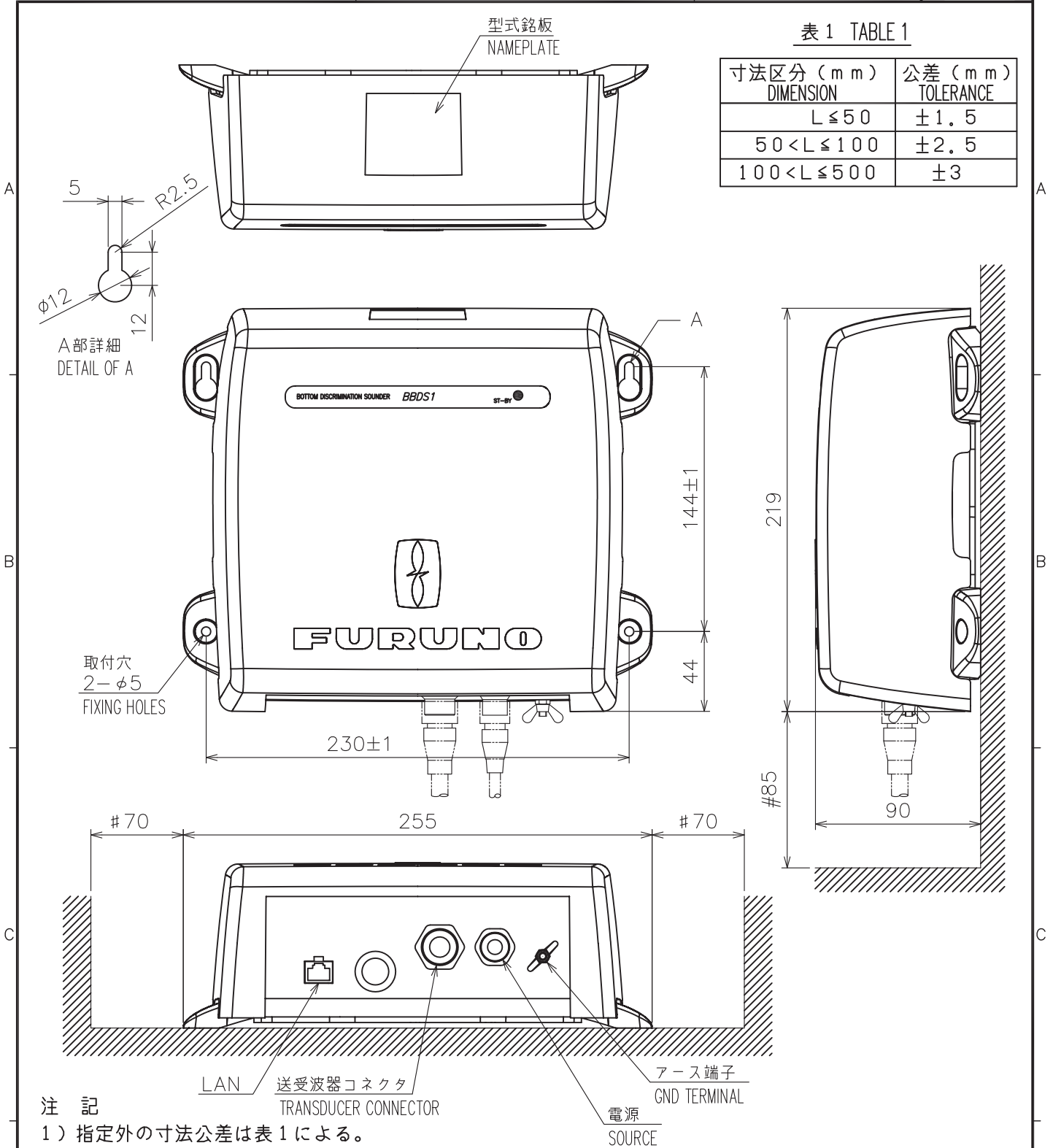

注 記

- 1) 指定外の寸法公差は表 1 による。
- 2) # 印寸法は最小サービス空間寸法とする。
- 3) 取付ネジはトラスタップインネジ呼び径 4X20 を使用のこと。

NOTE

1. TABLE 1 INDICATES TOLERANCE OF DIMENSIONS WHICH IS NOT SPECIFIED.
2. #: MINIMUM SERVICE CLEARANCE.
3. USE TAPPING SCREWS $\phi 4 \times 20$ FOR FIXING THE UNIT.

DRAWN 2/Mar/2010 T.YAMASAKI		TITLE BBDS1
CHECKED 2/Mar/2010 T.TAKAHASHI		名称 底質判別魚探
APPROVED 8/Mar/2010 Y.NISHIYAMA	BBDS1	外寸図
SCALE 1/3	MASS 1.2 ±10% kg	NAME BOTTOM DISCRIMINATION SOUNDER
DWG. No. C2038-G01-A	REF. No. 02-162-100G-0	OUTLINE DRAWING

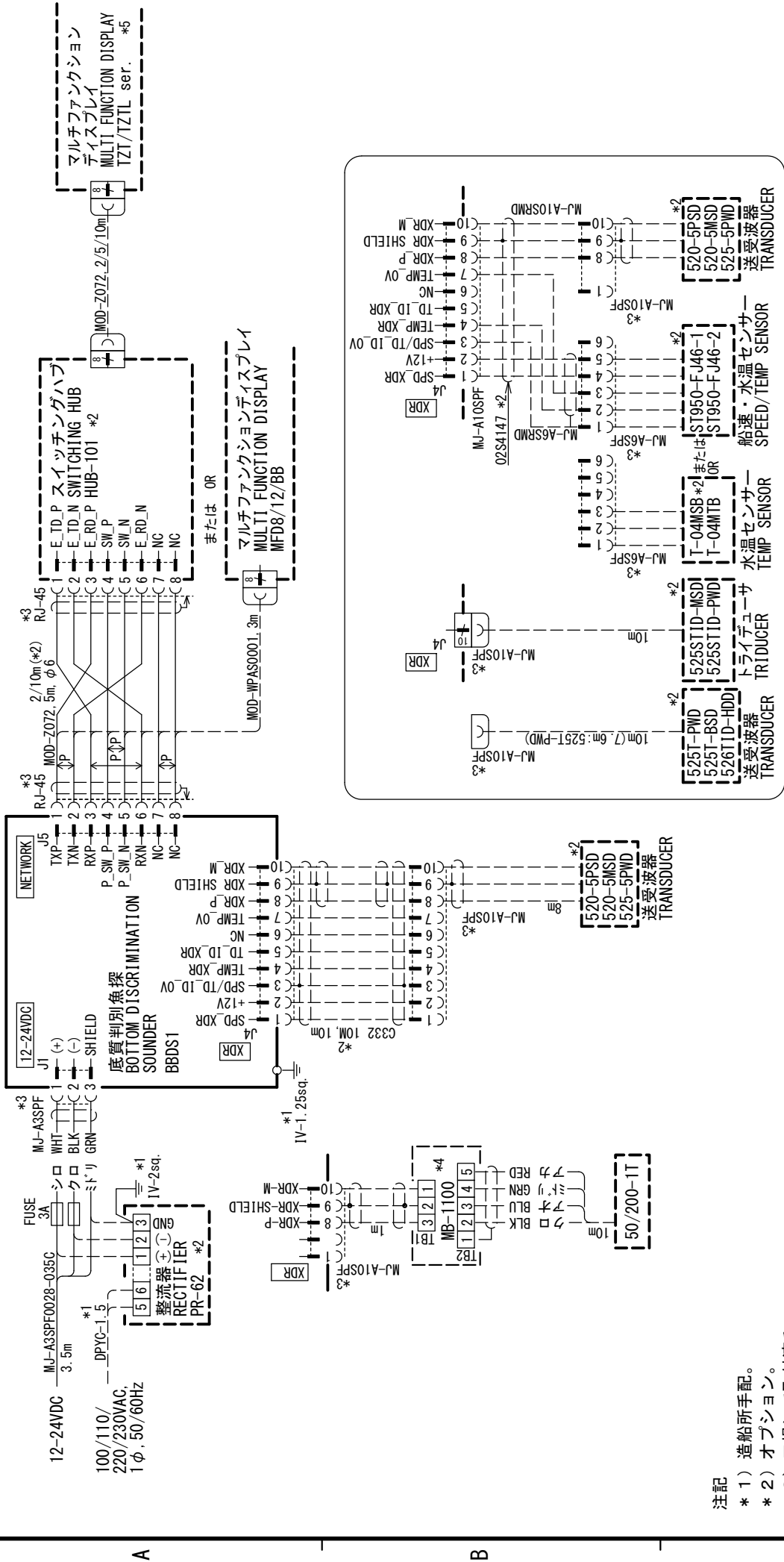

注記

- * 1) 造船所手配。
- * 2) オプション。
- * 3) 工場にて取付済み。
- * 4) BBDS1のジャンパー設定変更が必要。
- * 5) BBDS1のDIPスイッチ設定変更が必要。

NOTE

- * 1: SHIPYARD SUPPLY.
- * 2: OPTION.
- * 3: FITTED AT FACTORY.
- * 4: CHANGE JUMPER SETTING OF BBDS1.
- * 5: CHANGE DIP SWITCH SETTING OF BBDS1.

DRAWN	8/Feb/2023	S. HAN	TITLE	BBDS1
CHECKED	8/Feb/2023	T. YAMASAKI	名称	底質判別魚探
APPROVED	14/Feb/2023	H. MAKI	相互結線図	
SCALE	MASS	kg	NAME	BOTTOM DISCRIMINATION SOUNDER
DWG. No.	C2038-C01-M	REF. No.	02-162-1003-0	INTERCONNECTION DIAGRAM

FURUNO Worldwide Warranty for Pleasure Boats (Except North America)

This warranty is valid for products manufactured by Furuno Electric Co. (hereafter FURUNO) and installed on a pleasure boat. Any web based purchases that are imported into other countries by anyone other than a FURUNO certified dealer may not comply with local standards. FURUNO strongly recommends against importing these products from international websites as the imported product may not work correctly and may interfere with other electronic devices. The imported product may also be in breach of the local laws and mandated technical requirements. Products imported into other countries as described previously shall not be eligible for local warranty service.

For products purchased outside of your country please contact the national distributor of Furuno products in the country where purchased.

This warranty is in addition to the customer's statutory legal rights.

1. Terms and Conditions of Warranty

FURUNO guarantees that each new FURUNO product is the result of quality materials and workmanship. The warranty is valid for a period of 2 years (24 months) from the date of the invoice, or the date of commissioning of the product by the installing certified dealer.

2. FURUNO Standard Warranty

The FURUNO standard warranty covers spare parts and labour costs associated with a warranty claim, provided that the product is returned to a FURUNO national distributor by prepaid carrier.

The FURUNO standard warranty includes:

- Repair at a FURUNO national distributor
- All spare parts for the repair
- Cost for economical shipment to customer

3. FURUNO Onboard Warranty

If the product was installed/commissioned and registered by a certified FURUNO dealer, the customer has the right to the onboard warranty.

The FURUNO onboard warranty includes

- Free shipping of the necessary parts
- Labour: Normal working hours only
- Travel time: Up to a maximum of two (2) hours
- Travel distance: Up to a maximum of one hundred and sixty (160) KM by car for the complete journey

4. Warranty Registration

For the Standard Warranty - presentation of product with serial number (8 digits serial number, 1234-5678) is sufficient. Otherwise, the invoice with serial number, name and stamp of the dealer and date of purchase is shown.

For the Onboard Warranty your FURUNO certified dealer will take care of all registrations.

5. Warranty Claims

For the Standard Warranty - simply send the defective product together with the invoice to a FURUNO national distributor. For the Onboard Warranty – contact a FURUNO national distributor or a certified dealer. Give the product's serial number and describe the problem as accurately as possible.

Warranty repairs carried out by companies/persons other than a FURUNO national distributor or a certified dealer is not covered by this warranty.

6. Warranty Limitations

When a claim is made, FURUNO has a right to choose whether to repair the product or replace it.

The FURUNO warranty is only valid if the product was correctly installed and used. Therefore, it is necessary for the customer to comply with the instructions in the handbook. Problems which result from not complying with the instruction manual are not covered by the warranty.

FURUNO is not liable for any damage caused to the vessel by using a FURUNO product.

The following are excluded from this warranty:

- a. Second-hand product
- b. Underwater unit such as transducer and hull unit
- c. Routine maintenance, alignment and calibration services.
- d. Replacement of consumable parts such as fuses, lamps, recording papers, drive belts, cables, protective covers and batteries.
- e. Magnetron and MIC with more than 1000 transmitting hours or older than 12 months, whichever comes first.
- f. Costs associated with the replacement of a transducer (e.g. Crane, docking or diver etc.).
- g. Sea trial, test and evaluation or other demonstrations.
- h. Products repaired or altered by anyone other than the FURUNO national distributor or an authorized dealer.
- i. Products on which the serial number is altered, defaced or removed.
- j. Problems resulting from an accident, negligence, misuse, improper installation, vandalism or water penetration.
- k. Damage resulting from a force majeure or other natural catastrophe or calamity.
- l. Damage from shipping or transit.
- m. Software updates, except when deemed necessary and warrantable by FURUNO.
- n. Overtime, extra labour outside of normal hours such as weekend/holiday, and travel costs above the 160 KM allowance
- o. Operator familiarization and orientation.

FURUNO Electric Company, March 1, 2011

FURUNO Warranty for North America

FURUNO U.S.A., Limited Warranty provides a twenty-four (24) months LABOR and twenty-four (24) months PARTS warranty on products from the date of installation or purchase by the original owner. Products or components that are represented as being waterproof are guaranteed to be waterproof only for, and within the limits, of the warranty period stated above. The warranty start date may not exceed eighteen (18) months from the original date of purchase by dealer from Furuno USA and applies to new equipment installed and operated in accordance with Furuno USA's published instructions.

Magnetrons and Microwave devices will be warranted for a period of 12 months from date of original equipment installation.

Furuno U.S.A., Inc. warrants each new product to be of sound material and workmanship and through its authorized dealer will exchange any parts proven to be defective in material or workmanship under normal use at no charge for a period of 24 months from the date of installation or purchase.

Furuno U.S.A., Inc., through an authorized Furuno dealer will provide labor at no cost to replace defective parts, exclusive of routine maintenance or normal adjustments, for a period of 24 months from installation date provided the work is done by Furuno U.S.A., Inc. or an AUTHORIZED Furuno dealer during normal shop hours and within a radius of 50 miles of the shop location.

A suitable proof of purchase showing date of purchase, or installation certification must be available to Furuno U.S.A., Inc., or its authorized dealer at the time of request for warranty service.

This warranty is valid for installation of products manufactured by Furuno Electric Co. (hereafter FURUNO). Any purchases from brick and mortar or web-based resellers that are imported into other countries by anyone other than a FURUNO certified dealer, agent or subsidiary may not comply with local standards. FURUNO strongly recommends against importing these products from international websites or other resellers, as the imported product may not work correctly and may interfere with other electronic devices. The imported product may also be in breach of the local laws and mandated technical requirements. Products imported into other countries, as described previously, shall not be eligible for local warranty service.

For products purchased outside of your country please contact the national distributor of Furuno products in the country where purchased.

WARRANTY REGISTRATION AND INFORMATION

To register your product for warranty, as well as see the complete warranty guidelines and limitations, please visit www.furunousa.com and click on "Support". In order to expedite repairs, warranty service on Furuno equipment is provided through its authorized dealer network. If this is not possible or practical, please contact Furuno U.S.A., Inc. to arrange warranty service.

FURUNO U.S.A., INC.
Attention: Service Coordinator
4400 N.W. Pacific Rim Boulevard
Camas, WA 98607-9408
Telephone: (360) 834-9300
FAX: (360) 834-9400

Furuno U.S.A., Inc. is proud to supply you with the highest quality in Marine Electronics. We know you had several choices when making your selection of equipment, and from everyone at Furuno we thank you. Furuno takes great pride in customer service.



Declaration of Conformity



We **FURUNO ELECTRIC CO., LTD.**

(Manufacturer)

9-52 Ashihara-Cho, Nishinomiya City, 662-8580, Hyogo, Japan

(Address)

declare under our sole responsibility that the product

BOTTOM DISCRIMINATION SOUNDER BBDS1

(Model name, type number)

to which this declaration relates conforms to the following standard(s) or other normative document(s)

EU
EMC Directive 2014/30/EU

UK
SI 2016 No.1091 EMC Regulations 2016 as amended

IEC 60945 Ed.4.0: 2002

EN 60945: 2002

For assessment, see

- Test report
Furuno Labotech International Co., Ltd.
FLI 12-10-023, 22 Jun 2010

For assessment, see

- Test report
Furuno Labotech International Co., Ltd.
FLI 12-10-023, 22 Jun 2010

(title and/or number and date of issue of the standard(s) or other normative document(s))

On behalf of Furuno Electric Co., Ltd.

Nishinomiya City, Japan
26 July 2021

(Place and date of issue)

Akihiko Kanechika
Department General Manager
Quality Assurance Department

(name and signature or equivalent marking of authorized person)

PSTI Statement of Compliance

We **FURUNO ELECTRIC CO., LTD.**

(Name of manufacturer of the product)

9-52 Ashihara-Cho, Nishinomiya City, 662-8580, Hyogo, Japan

(Address of manufacturer of the product)

declare under our sole responsibility that the product

**BOTTOM DISCRIMINATION SOUNDER,
BBDS1**

(Product type, batch)

October / 31 / 2025

(Support period for the product)

https://www.furuno.co.jp/en/csr/sociality/customer/product_security.html

(Weblink for latest information and contact to report to the manufacturer security issues)

to which this declaration relates conforms to the following standard(s) or other normative document(s)

Product Security and Telecommunications Infrastructure Act 2022

Product Security and Telecommunications Infrastructure (Security Requirements for
Relevant Connectable Products) Regulations 2023 Schedule 1

On behalf of Furuno Electric Co., Ltd.

Nishinomiya City, Japan
24 April 2024

(Place and date of issue)

Akihiko Kanechika
Department General Manager
Quality Assurance Department

(Signature, name and function of the signatory)





FURUNO ELECTRIC CO., LTD.

9-52, Ashihara-cho,
Nishinomiya, 662-8580, JAPAN

·FURUNO Authorized Distributor/Dealer

All rights reserved. Printed in Japan

A: JUL. 2010
N: JUN. 05, 2024

Pub. No. OME-20380-N
(REFU) BBDS1

