



INSTRUCTION MANUAL

VHF-UHF FM REPEATER

X↔BAND 50 REPEATER



IMPORTANT

READ THIS INSTRUCTION MANUAL CAREFULLY before attempting to operate the repeater.

SAVE THIS INSTRUCTION MANUAL—This manual contains important safety and operating instructions for the series.

PRECAUTION

⚠WARNING HIGH VOLTAGE! NEVER attach an antenna or internal antenna connector during transmission. This may result in an electrical shock or burn.

⚠WARNING HIGH VOLTAGE! NEVER install the antenna at any place that person touch the antenna easily during transmission. This may result in an electrical shock or burn.

⚠NEVER apply AC to the [BATTERY] terminals on the repeater rear panel. This could cause a fire or damage the repeater.

⚠NEVER apply more than 16 V DC, such as a 24 V battery, to the [BATTERY] terminals on the repeater rear panel. This could cause a fire or damage the repeater.

⚠NEVER let metal, wire or other objects touch any internal part or connectors on the rear panel of the repeater. This may result in an electric shock.

⚠NEVER expose the repeater to rain, snow or any liquids.

AVOID using or placing the repeater in areas with temperatures below -30°C (-22°F) or above $+60^{\circ}\text{C}$ ($+140^{\circ}\text{F}$). Be aware that temperatures on a vehicle's dashboard can exceed 80°C ($+176^{\circ}\text{F}$), resulting in permanent damage to the repeater if left there for extended periods.

AVOID placing the repeater in excessively dusty environments or in direct sunlight.

EXPLICIT DEFINITIONS

WORD	DEFINITION
WARNING	Personal injury, fire hazard or electric shock may occur.
CAUTION	Equipment damage may occur.
NOTE	If disregarded, inconvenience only. No risk of personal injury, fire or electric shock.

AVOID putting anything on top of the repeater. This will obstruct heat dissipation. Place the repeater in a secure place to avoid inadvertent use by children.

BE CAREFUL! The heatsinks will become hot when operating the repeater continuously for long periods.

BE CAREFUL! If a linear amplifier is connected, set the repeater's RF output power to less than the linear amplifier's maximum input level, otherwise, the linear amplifier will be damaged.

Use Icom microphones only (optional). Other manufacturer's microphones have different pin assignments, and connection to the X—Band series may damage the repeater.

For U.S.A. only

CAUTION: This repeater is intended for use as a fixed station with the antenna located outdoors on the rooftop or on antenna tower, or indoors with the antenna located near the repeater.

The Icom America Systems logo is a trademark of Icom, Inc.

FORWARD

Thank you for purchasing this Icom America Systems X—BAND 50 VHF/UHF FM REPEATER. With proper care, this product should provide you years of trouble-free operation.

▣ FEATURES

- *Automatic battery backup charging system*
A built-in backup system supports automatic switching to an external power supply (13.6 V DC) if the AC power supply fails, and then recharges battery when power is restored.
- *Multiple CTCSS & DTCS tone memories*
One CTCSS/DTCS tone (TX/RX tones respectively) can be programmed in a channel. Ideal for many different applications.
- *Other features*
 - PC programmable
 - 19 inch rack mount or desktop
- *Internal controller*
Internal controller with programmable Hang Timer
- *Local controlled operation;*
can be used as a dual base unit
- *DB25 Accessory Connector*
with EPTT, COR, DISC, EMOD and AFO for each radio
- *Built in AC EMI Filter*
- *Dual forced Air CPU controlled cooling fans*

SUPPLIED ACCESSORIES

The following accessories are supplied with X—Band 50 series

[AC120V version]

- ① AC power cable (OPC-510) 1

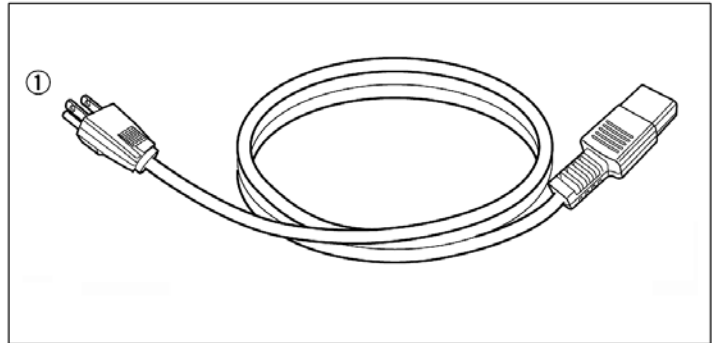

PANEL DESCRIPTION

■ Front Panel

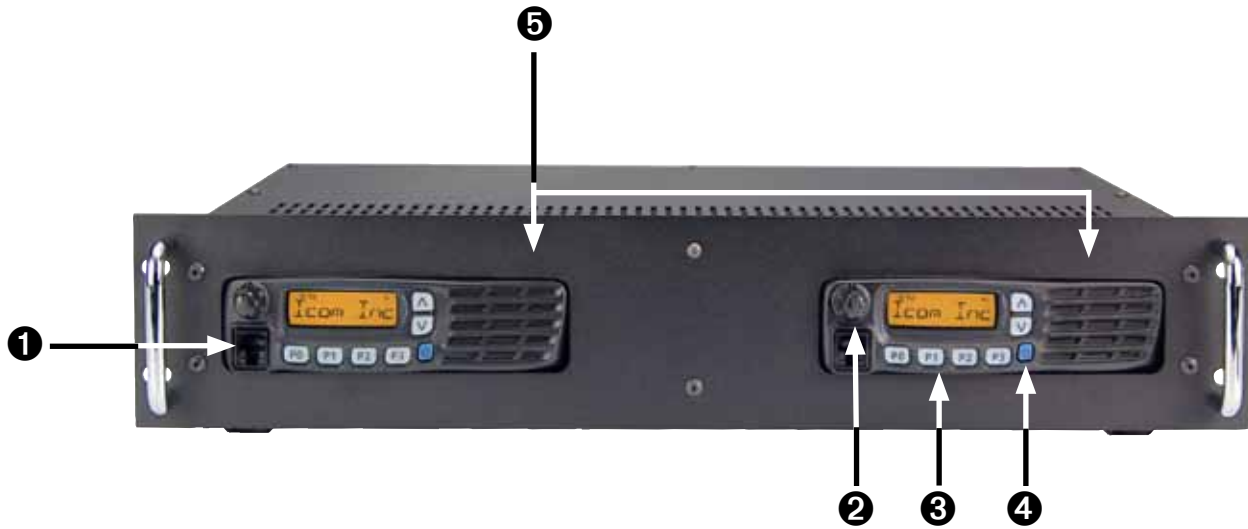

❶ MICROPHONE/SPEAKER CONNECTOR [MIC/SP]

This 8-pin modular jack accepts the optional microphone.

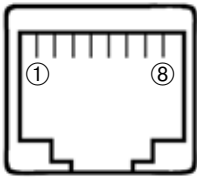

- ❶ +8 V DC output (Max. 10 mA)
- ❷ I/O port for PC programming
- ❸ AFO
- ❹ M PTT (Input port for TX control)
- ❺ Microphone ground
- ❻ Microphone input
- ❼ Ground
- ❽ CLI (Input port for monitor control)

❷ VOLUME CONTROL [VOLUME]

Adjusts the audio output level.

❸ DEALER PROGRAMMABLE KEYS

P0, P1, P2, P3

❹ POWER SWITCH [POWER]

Push to turn the power ON and OFF.

❺ INTERNAL SPEAKER

Monitors received signals.

■ Front Panel



① AF VOLUME CONTROL KNOB

Rotate the knob to adjust the audio output level.

- Minimum audio level is pre-programmed.

② FUNCTION DISPLAY

Displays a variety of information, such as an operating channel number/name.

NOTE: The above functions depend on pre-programming.

③ POWER SWITCH [POWER]

Push to turn the power ON and OFF.

- The following functions are available at power ON as options:
 - Automatic scan start
 - Password prompt
 - Set mode

④ DEALER-PROGRAMMABLE KEYS [P0] to [P3]

Desired functions can be programmed independently by your dealer.

⑤ MICROPHONE CONNECTOR

Connect the supplied microphone or optional DTMF microphone.

⑥ CHANNEL CONTROL KEYS

NEVER connect non-specified microphones. The pin assignments may be different and the transceiver may be damaged.

■ Rear Panel

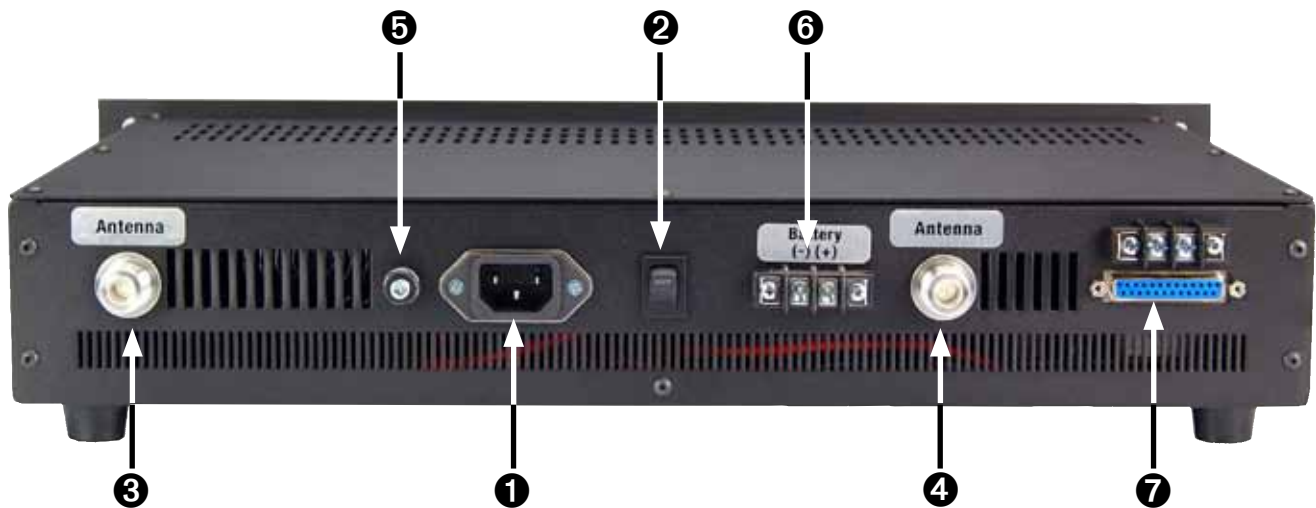

❶ AC POWER SOCKET [AC]

Connects the supplied AC power cable to a domestic AC outlet.

❷ POWER SWITCH [POWER]

Toggles to turn the repeater power ON or OFF. Located on the back panel of the repeater.

❸ RIGHT Radio ANTENNA CONNECTOR

➔ Connect the correct band antenna (impedance: 50 Ω).

❹ LEFT Radio ANTENNA CONNECTOR

➔ Connect the correct band antenna (impedance: 50 Ω).

❺ GROUND TERMINAL [GND]

Ground the repeater through this terminal to prevent electric shocks, TVI, BCI and other problems.

❻ DC POWER INPUT TERMINALS [BATTERY]

Connects the 12 V storage battery for the repeater backup when the AC power is interrupted. These terminals are also used for DC power operation.

❼ ACCESSORY CONNECTOR [ACC]

DB25 connects to the remote controller.
 • See pgs. 3, 4 for accessory connector information.

CAUTION: NEVER short the (+) line of the DC power cable to repeater's chassis, when connecting DC power cable to the [BATTERY] terminals. Otherwise, there is danger of electric shock and/or equipment damage.

■ Repeater Controller
Programming Both Mobile Radios
 CS-F3020/F5010/F5020

- Go to LMR>Memory CH>1:
 Program the TX and RX
- Set the CTCSS/CDCSS Tone
- Set RF Power to High
- LMR > External I/O > Option
 IGN SW = inhibit
 Ext. EPTT > Tone Mute EPTT = off
 Ext. Out (EXO) / Horn > RX EXO = on
- LMR External I/O > Port Settings
 EXT. I/O 4 Output Null
 EXT. I/O 6 Output Null
 EXT. I/O 7 AFO
 EXT. I/O 10 Null
 EXT. I/O 11 Audible
 EXT. I/O 14 EPTT

* Inside the radio, Solder jumper D and solder TX Data wire to F. See fig. 1 and fig. 2.
 Cut “k”, Solder “l”

HANG ON TIME CONFIGURATION

JP7	JP6	JP5	JP4	T sec.
1	1	1	1	0
0	1	1	1	0.5
1	0	1	1	1
1	0	1	1	1.5
1	1	0	1	2
0	1	0	1	2.5
1	0	0	1	3
0	0	0	1	3.5
1	1	1	0	4
0	1	1	0	4.5
1	0	1	0	5
0	0	1	0	5.5
1	1	0	0	6
0	1	0	0	6.5
1	0	0	0	7
0	0	0	0	7.5

** 1 = ON; 0 = OFF

CABLE CONNECTORS

X1	Accessory Connector	Right Radio
X2	Accessory Connector	Left Radio
X4	FAN	Left Radio
X6	J6 Optional Connector	Left Radio
X7	J6 Optional Connector	Right Radio
X8	FAN	Right Radio

CONTROLLER JUMPER SETTINGS

JP2	Internal Controller Disable
JP3	Transmit On
JP4	Hang On Time
JP5	Hang On Time
JP6	Hang On Time
JP7	Hang On Time
JP8	Audio On: Left to right Radio
JP9	Audio On: Right to left Radio

CONTROLLER ADJUSTMENTS

R9	TX Modulation	Right Radio
R59	TX Modulation	Left Radio

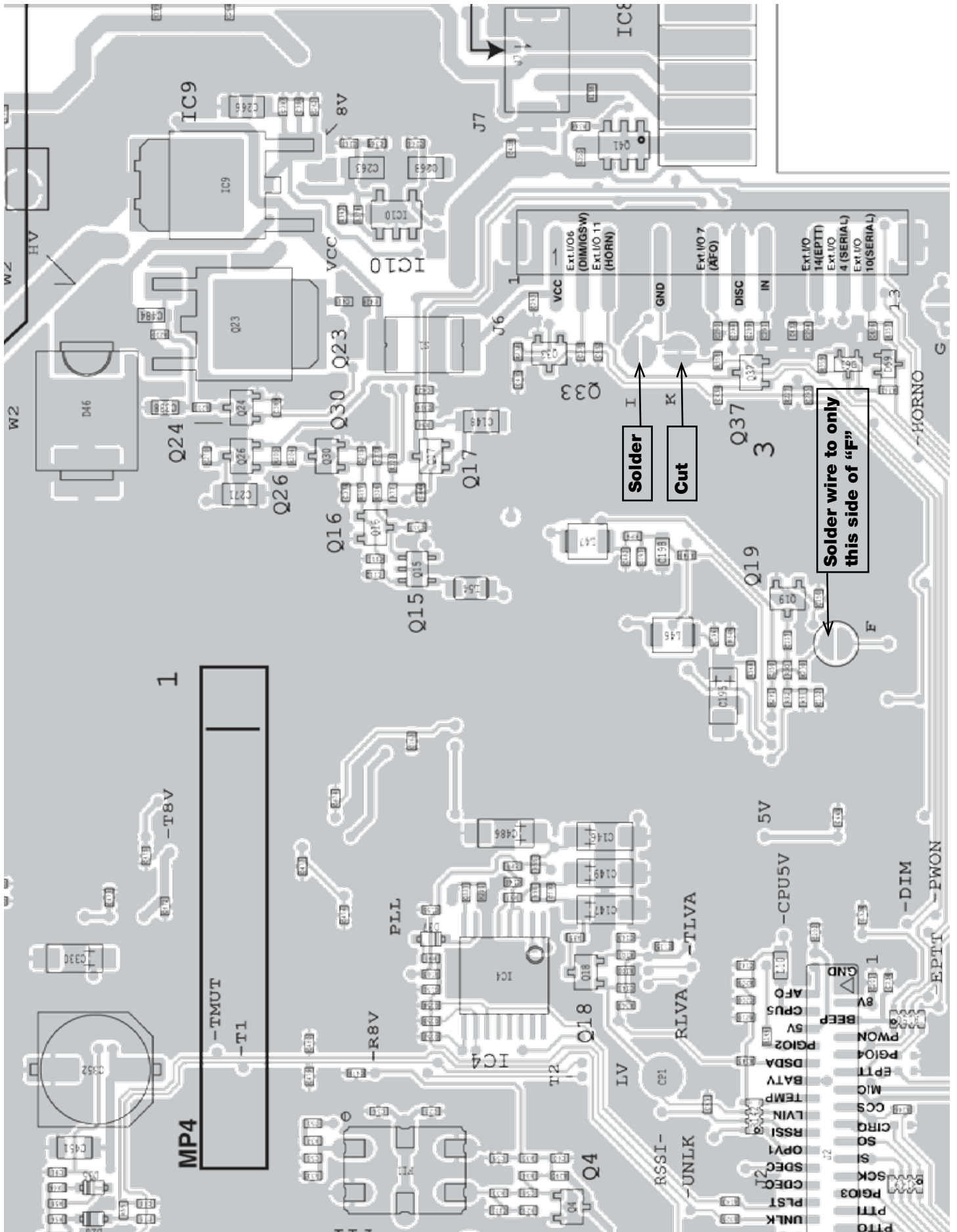
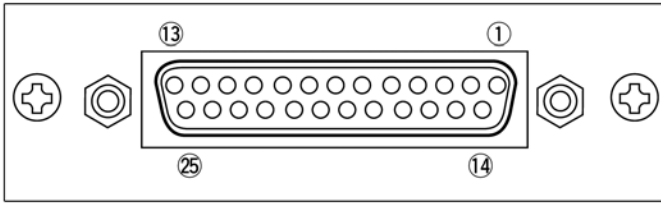

Fig. 1 VHF/UHF

■ Accessory connector



DB25 Pin Outs Configuration

Radio on Right			
Pin No.	Pin Name	Description	Specification
6	Vcc	+15V DC Supply for Internal Device	Maximum 1 A
7	GND	DC Ground, UHF Unit	
8	Busy	Output Terminal for Busy Signal	Open Collector+OFF, 0V=ON
9	AFO	Audio Output	Low Level Audio
10	DISC	Discriminator Output	
11	TXA	Transmit Audio	
12	PTT	External PTT	Active Low
13	TXD	Transmit Data Input	

Radio on Left			
Pin No.	Pin Name	Description	Specification
18	Vcc	+15V DC Supply for External Device	Maximum 1A
19	GND	DC Ground	
20	Busy	Output Terminal for Busy Signal	Open Collector+OFF, 0V=ON
21	AFO	Audio Output	Low Level Audio
22	DISC	Discriminator Output	
23	TXA	Transmit Audio	
24	PTT	External PTT	Active Low
25	TXD	Transmit Data Input	

■ Unpacking

After unpacking, immediately report any damage to the delivering carrier or dealer. Keep the shipping cartons.

For a description and a diagram of accessory equipment included with the X-BAND 50 series, see 'Supplied accessories' of this manual.

■ Selecting a location

Select a location for the repeater that allows adequate air circulation, free from extreme heat, cold, or vibrations, and away from TV sets, TV antenna elements, radios and other electromagnetic sources.

■ Antenna connections

For radio communications, the antenna is of critical importance, along with output power and sensitivity. Select antenna(s), such as a well-matched 50 Ω antenna, and feedline. 1.5:1 or better of Voltage Standing Wave Ratio (VSWR) is recommended for desired band. Of course, the transmission line should be a coaxial cable.

CAUTION: Protect repeater from lightning by using a lightning arrestor.

NOTE: There are many publications covering proper antennas and their installation. Check with your local dealer for more information and recommendations.

■ Grounding

To prevent electrical shock, television interference (TVI), broadcast interference (BCI) and other problems, ground the transceiver through the [GND] terminal on the rear panel.

For best results, connect a heavy gauge wire or strap to a long earth-sunk copper rod. Make the distance between the [GND] terminal and ground as short as possible.

WARNING: NEVER connect the [GND] terminal to a gas or electric pipe, since the connection could cause an explosion or electric shock.

American Communication Systems
Discover the Power of Communications™
<http://www.ameradio.com>

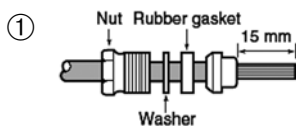

TYPE-N CONNECTOR INSTALLATION EXAMPLE

Slide the nut, flat washer, rubber gasket and clamp over the coaxial cable, then cut the end of the cable evenly.

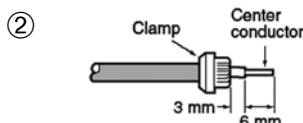

Strip the cable and fold the braid back over the clamp.

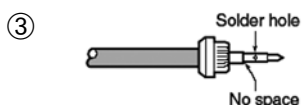

Soft solder the center conductor. Install the center conductor pin and solder it.



Carefully slide the plug body into place aligning the center conductor pin on the cable. Tighten the nut onto the plug body.

Be sure the center conductor is the same height as the plug body.

30 mm \approx 9/8 in 10 mm \approx 3/8 in 1–2 mm \approx 1/16 in

■ Required Connections



[DC POWER INPUT TERMINAL]

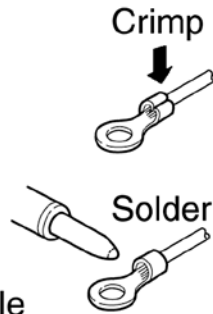
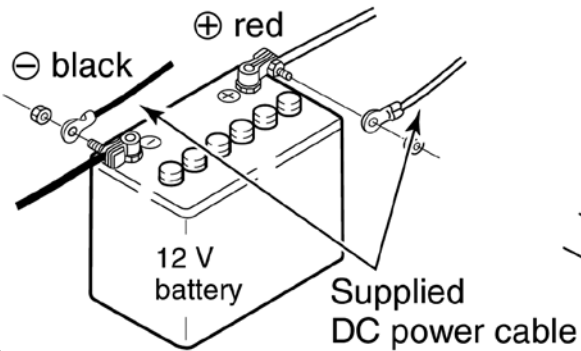

Make sure the back up battery is correctly connected. Use a cable with following current capacity. Solder or clamp the cable plug when connecting the power cable to the backup battery to prevent voltage drops.

Power cable current capacity: 25 A or more

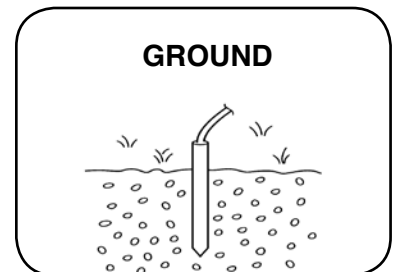
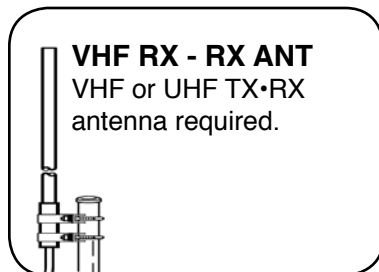
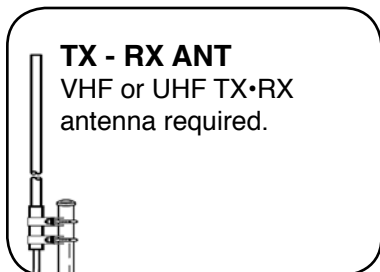

■ Power

Make sure the [POWER] switch is turned OFF when connecting an AC power cable and a backup battery (emergency power supply).

The X-Band 50 series can operate with an AC or DC power supply. If AC power is interrupted when operating the repeater with an AC power supply, power is automatically provided to the [BATTERY] terminals. Battery will be automatically recharged when AC power is restored.

□ In AC operation

CAUTION:

- Use the supplied AC power cable for connection to a domestic AC outlet.
- Extension cords should not be used unless absolutely necessary. Using improper extension cords could result in fire risk.

□ In DC operation

 **CAUTION:** Voltages greater than 16 V DC will damage the repeater. Check the source voltage before connecting the power cable.

- DO NOT place the backup battery on or near the repeater. Lead-acid batteries should be placed at least 5 m (16.4 ft.) away from the repeater. Use a heavy duty cable to make the connection and be sure both the positive (red) and negative (black) terminals are correctly connected.
- When connecting to the battery, keep in order to connect the DC power cable to the repeater first, then the positive (red) terminal and negative (black) terminal to the battery to prevent an electric shock.

■ Opening the repeater's case

Follow the case and cover opening procedures shown here when an optional unit is installed or adjust the internal units, etc.

CAUTION: Disconnect the AC power cable and/or DC power cable from the repeater. Otherwise, there is danger of electric shock and/or equipment damage.

- ① Remove 7 screws from the top of the repeater and 1 screw from the top front, then lift up the top cover.



■ Turning power ON

- ① On rear panel, push [POWER] to turn power ON.

■ Receiving and transmitting

□ Receiving

- ① Push [POWER] to turn power ON.
- ② Rotate [VOLUME] to adjust the audio output level.
- ③ Push to select the desired channel.
 - When receiving a signal, BUSY indicator turns ON and audio is emitted from the speaker.
 - Further adjustment of [VOLUME] to a comfortable listening level may be necessary at this point.

□ Transmitting

- ① Take the microphone off hook.
- ② Wait for the channel to become clear.
- ③ Push and hold [PTT] to transmit, then speak into the microphone at your normal voice level.
- ④ Release [PTT] to receive.

IMPORTANT:

To maximize the readability of the transmitted signal:

- ① Pause briefly after pushing [PTT].
- ② Hold the microphone 1 to 2 inch (2.5 to 5 cm) from your mouth, then speak into the microphone at a normal voice level.

■ Turning power ON

On rear panel, push [POWER] to turn power ON. LED will be on if there is AC or DC power in the unit.

On each radio, push [POWER] to turn power on to that radio.

Right Radio must be on for Internal Controller to function.

Push to select the desired channel on each radio.

Any radio traffic received on one radio that meets the programmed settings, will cause the other radio to key and pass audio.

XBand 50 is a Half Duplex device. Radio traffic can only pass one direction at a time. Keep Haas time settings low as your system allows.

■ Fuse replacement

If a fuse blows or the repeater stops functioning, try to find the source of the problem, and replace the damaged fuse with a new, rated fuse.

Replace the circuitry fuse as shown below.



“There are two fuses for each radio
The left fuses are for Left Radio
The right fuses are for Right Radio

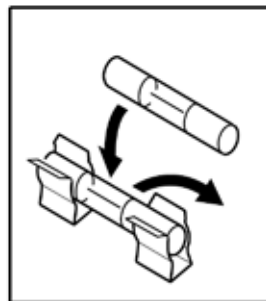

WARNING:

DISCONNECT the AC power cable and/or DC power cable from the repeater. Otherwise, there is a danger of electric shock and/or equipment damage.

■ Specifications

◆ X-Band 50 VHF		Specification		
GENERAL	• Frequency coverage		136–174 MHz	
	• Type of emission	Wide	16K0F3E (25.0 kHz)	
		Narrow	11K0F3E (12.5 kHz)	
	• Number of programable channels		128 channels (8 zones)	
	• Antenna impedance		50 Ω (nominal)	
	• Operating temperature range		–30°C to +60°C (–22°F to +140°F)	
	• Power supply requirement (nominal)		13.6 V DC (Negative ground)	
	• Current drain (approx.)	RX	Stand-by	300 mA
			Max.audio	1200 mA
		TX	at 25 W	7.0 A
			at 50 W	14.0 A
	• Dimensions (projections not included)	[25 W ver.]	480(W) x 133(H) x 364(D) mm; 18.90(W) x 5.24(H) x 14.33(D) in	
[50 W ver.]		480(W) x 133(H) x 364(D) mm; 18.90(W) x 5.24(H) x 14.33(D) in		
• Weight	[25 W ver.]	8.6 kg (19 lb)		
	[50 W ver.]	8.6 kg (19 lb)		
TRANSMITTER	• TX output power	[25 W ver.]	25 W (High), 10 W (Low2), 2.5 W (Low1)	
		[50 W ver.]	50 W (High), 25 W (Low2), 5.0 W (Low1)	
	• Modulation		Variable reactance frequency modulation	
	• Max. permissible deviation	Wide	±5.0 kHz	
		Narrow	±2.5 kHz	
	• Frequency error		±2.5 ppm	
	• Spurious emission		70 dB typ.	
	• Adjacent channel power	Wide	70 dB min.	
		Narrow	60 dB min.	
	• Audio frequency response		+1 dB to –3 dB of 6 dB/octave (from 500–2500 Hz)	
	• Audio harmonic distortion		3% typ. (with 1 kHz AF 40% deviation)	
	• FM hum and noise (without CCITT filter)	Wide	More than 40 dB (46 dB typ.)	
		Narrow	More than 34 dB (40 dB typ.)	
	• Limiting charact of modulation		70–100% of max. deviation	
• Microphone impedance		600 Ω		

■ Options

- HM-100 HAND MICROPHONE
- HM-100TN DTMF MICROPHONE Hand microphone with a DTMF keypad
- SM-25 DESKTOP MICROPHONE

	◆ X-Band 50 UHF		Specification	
GENERAL	• Frequency coverage		400–470 MHz [USA-01] 450–512 MHz [USA-02]	
	• Type of emission	Wide	16K0F3E (25.0 kHz)	
		Narrow	11K0F3E (12.5 kHz) 11K0F7E/D (12.5 kHz)* 8K10F1E/D (12.5 kHz)* 4K00F1E/D (6.25 kHz)*	
	• Number of programable channels		max. 512 channels (128 zones)	
	• Antenna impedance		50 Ω (nominal)	
	• Operating temperature range		–30° to +60°; –22°F to +140°F; –22°F to +140°F	
	• Power supply requirement (nominal)		13.6 V DC (nominal)	
	• Current drain (approx.)	RX	Stand-by	300 mA
			Max.audio	1200 mA
		TX	at 25 W	7.0 A
at 50 W			14.0 A	
• Dimensions (projections not included)		480(W) x 133(H) x 364(D) mm; 18.90(W x 5.24(H) x 14.33(D) in		
• Weight		8.6 kg (19 lb)		
TRANSMITTER	• Transmit output power		45 W	
	• Modulation		Variable reactance frequency modulation	
	• Max. permissible deviation	Wide	±5.0 kHz	
		Narrow	±2.5 kHz	
	• Frequency error		±1.0 ppm	
	• Spurious emission		75 dB typ.	
	• Adjacent channel power	Wide	More than 70 dB	
		Narrow	More than 60 dB	
	• Audio frequency response		+1 dB to –3 dB of 6 dB/octave (from 500–2500 Hz)	
	• Audio harmonic distortion		3% typ. (with 1 kHz AF 40% deviation)	
	• FM hum and noise (without CCITT filter)	Wide	More than 40 dB (45 dB typ.)	
		Narrow	More than 34 dB (40 dB typ.)	
• Limiting charact of modulation		70–100% of max. deviation		
• Microphone impedance		600 Ω		
RECEIVER	• Receive system		Double-conversion superheterodyne	
	• Intermediate frequencies		1st IF; 46.35 MHz, 2nd IF; 450 kHz	
	• Sensitivity		0.25 μV typ. at 12 dB SINAD	
	• Adjacent channel selectivity	Wide	More than 80 dB (85 dB typ.)	
		Narrow	More than 70 dB (75 dB typ.)	
	• Spurious response		More than 85 dB (90 dB typ.)	
	• Intermodulation		More than 75 dB (77 dB typ.)	
	• Hum and noise (without CCITT filter)	Wide	More than 45 dB (50 dB typ.)	
		Narrow	More than 40 dB (45 dB typ.)	
• Audio output power		4 W typ. at 10% distortion with a 4 Ω load		
• Audio output impedance		4 Ω		

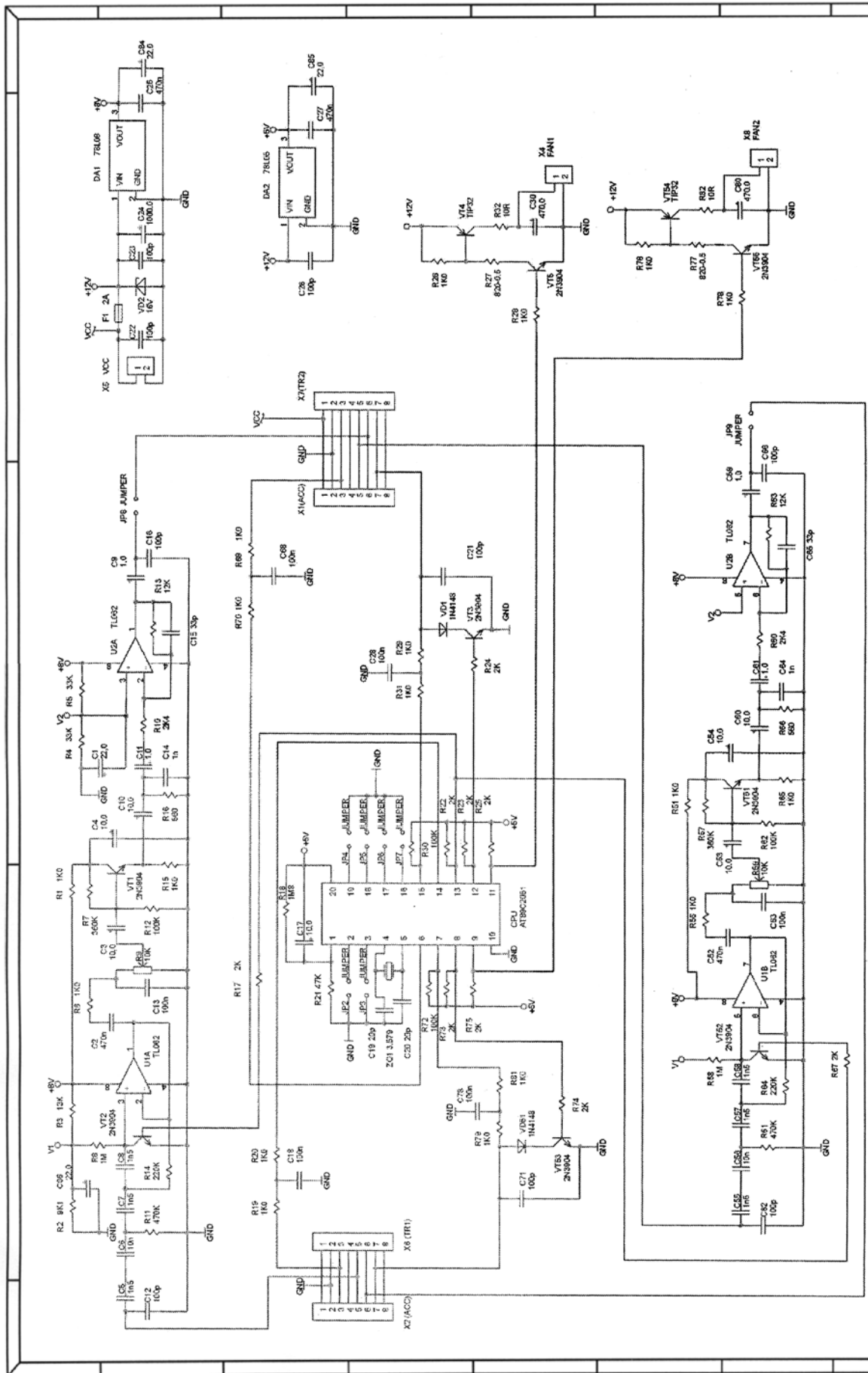

Icom America Systems

Date: 12-01-05 Title: CONTROLLER

Model No.: X-BAND 50 Manufacturer: Icom America Systems

Count on us!

American Communication Systems

Discover the Power of Communications™

<http://www.ameradio.com>

