



FROG-3 User Manual

Original Instructions For FROG Models:

FS-01 (320) Standard

FS-01 (340) Arctic

FS-01 (370) Tropical

Rev 19 | Issued 14-05-12



Reflex Marine

OFFSHORE ACCESS SPECIALISTS

A large, dynamic splash of blue water at the bottom of the page, with many bubbles and droplets.

Reflex Marine Ltd

Offshore Access Specialists

Purpose of Manual

This manual contains general instructions for the operation and maintenance of the FROG-3.

Safe and proper use of the FROG-3 is the responsibility of the user after having taken due regard of the information provided in this document.





The user must ensure that all safety measures as required by relevant legislation and by good operational practice are utilised for operations involving the FROG-3.

Adequate training must be provided for all personnel involved in the operation of the FROG-3 before the commencement of operational use.

For the purposes of this manual RML will be deemed to mean Reflex Marine Ltd.

Please retain this manual for future reference. Additional copies may be obtained by contacting Reflex Marine Ltd or by downloading the latest manual revision from www.reflexmarine.com/support.

Revision Approval

Revision	Date Issued	Status	Approved	Name	Signed
15.1	05 Oct 05	Revised	RML Operations Manager		
15.2	20 Sep 06	Revised	RML Operations Manager		
15.3	19 Sep 07	Revised	RML Operations Manager		
16	25 Jan 10	Revised	RML Operations Manager	Paul Wieczorek	
17	10 Jun 10	Revised	RML Operations Manager	David Brittan	
18	03 Sept 11	Revised	RML Operations Manager	David Brittan	
19	01 May 12	Current	RML Lead Engineer Production & Quality	Paul Onions	

All information disclosed in this document is the property of Reflex Marine Ltd except where otherwise stated. Reflex Marine Ltd reserves all patent rights, design rights, manufacturing rights, copyright and sales use rights thereto, and to any article disclosed within this document except where such rights are expressly granted to others or where not applicable to vendor proprietary parts.

© 2010 Copyright Reflex Marine Ltd, All rights reserved.

Document Revision & Control

To ensure that all changes to any of the documents contained in this manual are carried out and distributed in a controlled and authorised manner:

- i. Any proposed change in documentation must be submitted to the Reflex Marine Ltd Lead Engineer – Production & Quality in writing for authorisation. This refers to all drawings and documents contained in this manual.
- ii. A record must be maintained of all documentation changes.
- iii. A list of all revisions and amendments must be included in each controlled copy of this User Manual.
- iv. Upon revision of the FROG-3 User Manual, the manual will be distributed to the list of document holders indicated below. The control, revision and distribution of this manual will be the responsibility of the Reflex Marine Ltd Lead Engineer – Production & Quality.

Revisions

Rev No	Reason For Revision	Safety Critical Change
15.2	Old Sections 3.52 and 3.53 Operational guidance on night time operations and PPE recommendations. Old Sections 4.1, 4.3, 4.4 Revision to inspection and maintenance terminology.	No No
15.3	Old sections, 4.0, 4.1, 4.2, 4.3, 4.4, 4.5 Revision to inspection and maintenance procedures to update part numbers and offer sling set replacement frequency guidance (12 months).	Yes
16	The <u>Frog Client Technical Manual</u> has now been replaced with this <u>FROG-3 User Manual</u> . This manual is more focused on providing User Information in a format consistent with the other Reflex Marine Ltd products. The significant changes are listed below. Re-organisation of all sections of previous CTM into a standard Reflex Marine Ltd User Manual format. Deletion of Risk Register and Risk review papers which are ancillary to the manual. (These are still available as separate document downloads from www.reflexmarine.com/support). <u>New Sections added :</u> Section 5.6 - Seating and Load distribution added Section 5.7 - Luggage Storage Section 5.8 - Seatbelt Operation Section 5.9 - Rider instructions added Section 5.10 - Emergency stop procedure added <u>Revised Sections</u> Section 6 - Inspection, Testing and Maintenance. The whole section has been revised to align recommended inspection and maintenance to the 'degree of use' and provide guidance on unit lifetime and retirement policy. Improved inspection checklist templates are	No No No No Yes

	included for a range of recommended inspection points.	
17	<p><u>Minor edits</u> Section 2.1 Model No from HC9-01 to FS-01 Section 5.12.2 vi: Change from remove nut to slacken nut</p> <p><u>Corrections</u> Sections 6.5 & 6.6 and 6.7 –Inspection Check Lists Forms</p> <ul style="list-style-type: none"> Point 2 : delete “through the lifting bolt retaining sleeve” – not relevant to Frog 3 Point 4 : Replace ‘alignment’ with ‘anti-rotation’ Point 5 : Delete word ‘clevis’ – not relevant for Frog 3 Point 6 : Change ‘alignment roll pin on older models’ to ‘keel plate nut roll pin on older models’ - clarity Point 6 : Delete ‘tamper proof seal’ not present. <p>Section 6.10.1 : Kit Listings</p> <ul style="list-style-type: none"> Critical Parts Kits for Low Temperature M40 Frogs : Add sling cover. Restraint Harness Kit Numbers corrected <p>Include latest drawing FS-GA1 Rev B showing correct text for SWL = 330 Kg Include latest drawing FS-GA2 Rev B : showing tamper proof seals fitted Include latest drawing FS-GA3 Rev B : previously omitted showing current seat arrangement Include latest drawing F-ASY-11 Rev B ; change of word Ferrule to Thimble Appendix C : Parts Listing</p> <ul style="list-style-type: none"> F -01 – 049 : Buoyancy fitting button head screws : Correct the material description to 304 Stainless steel F-01 – 221 : Seat assembly anti rotation bolt : Correct the material description to 17-4PH 15% chrome alloy steel. 	<p>No</p> <p>No</p> <p>No</p> <p>No</p> <p>No</p> <p>No</p> <p>No</p>
18	<p><u>Overview of Major Revisions</u></p> <ul style="list-style-type: none"> Original Instructions added to cover page as per Machinery Directive Alternative Operating Limit Methodology added Clarified SWL and Passenger Loading Limitations (330Kgs and 270Kgs limits) New EC type examination and ABS PDA cert added New ‘Ultra High’ Usage Category defined with corresponding inspection frequencies. Parts Kits updated and new kit numbers The parts listings have been removed from the User Manual. Parts listings will in future be available online (or directly from Reflex Marine) , where the parts list for the serial number of each Frog can be matched <p><u>Revised Sections</u></p> <ul style="list-style-type: none"> Section 2.1: FROG model numbers updated Section 5.4.2: References to new drawing and part numbers Section 5.7 Revised to advise that oversized luggage should be transferred as a separate lift. Section 5.12.2: Buoyancy reconfiguration diagram updated to remove references to old P/Ns 	<p>NO safety critical changes occur in this revision. All changes are enhancements to the documentation and the advice regarding Frog 3 operation and maintenance.</p>

	<ul style="list-style-type: none"> • Section 5.12.4: Torque setting for buoyancy fixings added. • Section 6.3: Inspection frequency table has been updated to include an ultra-high usage category • Section 6.4: <ul style="list-style-type: none"> The support drawings detailed in the guidance notes have been updated to the new part numbers. New separate anti-rotation fitting check added. New separate spring check added Diagram 4b corrected to include a tamper proof seal • Section 6.5: <ul style="list-style-type: none"> New separate check for the anti-fouling bracket and shackle spacer added New separate spring check added New alignment cross bolt check added General formatting changes • Section 6.6: <ul style="list-style-type: none"> Dye penetration test advise added to point 1 Back up eye torque setting added Thread lubricant application requirements added to Keel Nut check Separate anti-fouling bracket & shackle spacer check added Separate spring check added Separate sliding sleeve cross bolt check added General formatting changes • Section 6.7: <ul style="list-style-type: none"> Separate spring check added Separate sliding sleeve cross bolt check added • Section 6.8 <ul style="list-style-type: none"> Load test held for 5 mins. • Section 6.8.2 <ul style="list-style-type: none"> Model numbers updated • Section 6.10.1 <ul style="list-style-type: none"> New part numbers for spares kits Thread lubricant added to relevant parts kits 1 x tamper proof seal added to the parts kits that contain type 2 keel assemblies Single slings have been replaced with new sling kits • Section 11.3 <ul style="list-style-type: none"> Parts lists have been deleted from the User Manual • Appendix B: <ul style="list-style-type: none"> Drawings have been updated with new assembly drawings. Drawings referring to previous Frog 3 models have been removed to avoid confusion. • Appendix F : <ul style="list-style-type: none"> New CE marking and ABS Type approval certificates attached for all units beyond FS:412 	
19	<ul style="list-style-type: none"> • Section 6.3 Table 3: <ul style="list-style-type: none"> New 'Very Low' Usage Category defined with corresponding inspection frequencies. Load Test requirements also revised. 	No

Distribution List

Controlled/uncontrolled copies of this manual are issued to the following:

Reflex Marine Ltd				
Ref.	Status	Issued To	Date Issued	Format
Master	Controlled	RML Truro J Cryan	14 May 2012	Electronic
RML 1	Uncontrolled	RML Newbury P Onions	14 May 2012	Electronic
RML 2	Uncontrolled	RML Aberdeen S Watson	14 May 2012	Electronic

Notification of this manual revision is sent to the following:

Reflex Marine Ltd				
Ref.	Status	Issued To	Date Issued	Format
RML 3	Notification	RML Website J Strong	14 May 2012	Electronic
RML 4	Notification	RML Sales Team Coordinator K Hallowes	14 May 2012	Electronic

Table of Contents

Purpose of Manual..... 2

Revision Approval 2

Document Revision & Control..... 3

Revisions 3

Distribution List..... 6

Table of Contents..... 7

1 INTRODUCTION..... 10

 1.1 Scope..... 10

 1.2 Introduction 10

 1.3 Safety 11

Note: Competent Person 11

2 SPECIFICATION FROG-3..... 12

 2.1 Specification Summary..... 12

 2.2 Design..... 13

 2.3 Certification and Documentation 14

3 OPERATING PARAMETERS 15

 15

 3.1 Introduction 15

 3.2 Operating Parameters - Sea State..... 16

 3.2.1 Site Specific Frog Transfer Operating Parameters 17

 3.3 Operating Parameters - Additional Factors 17

4 TRANSFER PLANNING..... 18

 4.1 Risk Assessment and Method Statement 18

 4.2 Communications 18

 4.3 Information Exchange..... 18

 4.4 Operational Planning 19

 4.5 Briefings 19

 4.6 Supervision..... 19

 4.7 Transfer Log 19

 4.8 Emergency Transfers..... 20

 4.9 Training 20

 4.10 Night Time Operations..... 20

5 OPERATING PROCEDURE 21

 5.1 Pre-Transfer Activity List..... 21

 5.2 Lifting 21

 5.3 Landing..... 21

 5.4 Crane Operator Guidance 22

 5.4.1 Use of Shorter Slings 22

 5.4.2 Sling Leg Arrangement and Observed Snagging Issue 22

 5.5 Use of Tag Lines 23

5.6	Seating and Load Distribution.....	23
5.7	Luggage Storage.....	24
5.8	Seatbelt Operation.....	25
5.9	Rider Instructions.....	26
5.10	Emergency Stop Procedure.....	26
5.11	Personal Protective Equipment (PPE).....	27
5.11.1	Personal Flotation Devices (PFD's).....	28
5.11.2	Immersion Suits.....	29
5.12	Stretcher Mode.....	30
5.12.1	Converting FROG-3 to Stretcher Mode (Figure 7).....	30
5.12.2	Stretcher Mode Conversion Procedure.....	30
5.12.3	Positioning the Stretcher.....	32
5.12.4	3-Seat Mode Conversion Procedure.....	32
5.12.5	Stretcher (Optional) Accessory.....	33
6	PERIODIC INSPECTION, TESTING AND MAINTENANCE.....	34
	34	
6.1	Introduction.....	34
6.2	Definitions.....	34
6.3	Frequency of Inspection, Test and Maintenance.....	35
6.4	Pre-Operational Visual Check.....	37
6.5	Visual Inspection.....	39
6.6	Examination.....	42
6.7	Post Load Test Visual Inspection.....	46
6.8	Proof Load Testing.....	49
6.8.1	Load Test Procedure.....	50
6.8.2	Inspection Data Plate.....	50
6.9	Sling Replacement and Management.....	51
6.9.1	Sling Set (Critical Part) Replacement.....	51
6.9.2	Sling Set Management.....	51
6.10	Spares Kits and Replacement Parts.....	52
6.10.1	Spares Kits.....	53
6.10.2	All Other Replacement Parts.....	57
6.11	Unit Replacement Recommendation.....	57
7	UNIT IDENTIFICATION.....	58
7.1	Product ID Numbers.....	58
7.2	Part Numbers.....	58
7.3	FROG-3 Serial Numbers.....	58
7.4	Component Serial Numbers.....	58
8	HANDLING, SHIPPING AND STORAGE.....	59
8.1	Dimensions.....	59
8.2	Handling & Transportation.....	59
8.2.1	Forklift.....	59
8.2.2	Crane.....	59
8.2.3	Securing.....	59
8.2.4	Inspection.....	59
8.2.5	Preparation for Road Transport.....	60

8.2.6	Containerisation.....	60
8.2.7	Storage	61
8.2.8	Feet Deformation During Storage.....	61
9	APPENDIX A – TRANSFER LOG.....	62
10	APPENDIX B – DRAWINGS.....	63
11	APPENDIX C – PARTS AND MATERIAL SPECIFICATIONS.....	70
11.1	Parts	70
11.2	Definition According to Criticality.....	70
11.3	Fastener Specifications	70
11.4	Certification.....	70
12	APPENDIX D – FROG-3 MARKINGS.....	71
12.1	Essential Marking Requirements	71
12.2	Decal - Vinyl Stickers - Located on Outside of Buoyancy Units.....	72
12.3	Decal - Vinyl Stickers - Located Inside of Lower Buoyancy Units.....	72
12.4	Decal - Operating Instructions - Located Inside of Upper Buoyancy Units.....	72
12.5	Decal - Operating Instructions - Located on Seat Back.....	73
12.6	FROG-3 Column Marking Plan	74
13	APPENDIX E – ACCESSORIES.....	75
	Skid Trolley.....	75
	Strobe Light.....	75
	Stretcher (MedEvac)	75
	75	
	Protective Cover.....	75
	75	
	Rigid Luggage Box	75
	Multi-Lingual Operational Briefing DVD's.....	75
14	APPENDIX F – INDEPENDENT CERTIFICATION	76
14.1	EC Type examination certificate (from unit number FS 412 onwards).....	76
14.2	ABS Product Design Assessment Certificate (from unit number FS 412 onwards)	77

1 INTRODUCTION

1.1 Scope

This User Manual is for the three passenger capacity FROG-3 (Model FS-01).

Note: *Throughout this manual the use of this symbol “  “ denotes safety critical information.*

1.2 Introduction

The FROG-3 Personnel Transfer Capsule (PTC) is a personnel transfer device designed to provide increased passenger protection when carrying out the transfer of personnel between vessels and installations.

Crane personnel transfers are carried out for a wide variety of reasons including routine, urgent operational and emergency reasons. The FROG-3 can accommodate a stretcher to transfer injured personnel in a protected environment.

The FROG-3 comprises the following two main assemblies; firstly, the stainless steel outer framework containing polyethylene buoyancy panels, secondly, a spring-dampened seating assembly mounted on a central column. All materials have been selected specifically to minimise corrosion in the marine environment.

The outer framework protects passengers from impacts and contains the buoyant elements which ensure the FROG-3 floats and is self-righting in water. At its base are keel weights which assist in rapid self-righting.

The outer shell lands on three tripod feet that provide shock absorption and ensure that the FROG-3 is stable on uneven surfaces or when landing on a heaving vessel. The outer shell also has three large open accesses that allow rapid unimpeded exit.

During transit passengers are seated and secured with full harnesses to protect them against whiplash and falling. Seating is mounted on a sprung carriage to provide protection against heavy landings.

The sling assembly is of a special design to prevent rotation.

Note: *The regulations governing personnel transfer operations vary greatly from country to country and it is imperative that operators of the equipment establish the relevant requirements for the area of operation.*

1.3 Safety



Personnel transfer is a safety critical activity. The following items must be observed to properly control safe transfers.

- i. Proper planning of the transfer operation is essential. Planning must include a risk assessment and method statement which takes account of all environmental and operational factors. Assessing the impact of these factors on operational risk is best done by Competent Persons (see note below) experienced in use of the equipment and the local conditions.
- ii. It is imperative for the safe operation of the FROG-3 that each unit is periodically inspected and tested in accordance with the procedures and schedules set out within this document.
- iii. Operating parameters detailed in this document must be adhered to unless modified following on-site risk assessment and method statement by competent, experienced personnel.
- iv. The FROG-3 must only be used with properly designed, maintained and appropriately certified lifting equipment. (It should be noted that some national regulations require cranes to be specifically certified for man-riding operations).
- v. Supervisory personnel (including Deck Crews and Crane Operators) must be competent and must only operate the equipment following proper instruction in its use. Crane Operators should read the 'Crane Operator Guidance' contained within this document.
- vi. Pre-operational checks as detailed in this document must always be performed prior to use of the FROG-3.
- vii. Transfer personnel must receive a proper briefing on the FROG-3 and the transfer operation.
- viii. Transfer personnel must at all times be seated and properly strapped in using the harnesses supplied.
- ix. The FROG-3 must only be used as a personnel transfer device.
- x. The FROG-3 must not be used as a work-basket.

Note: Competent Person

A Competent Person is a person who has appropriate practical and theoretical knowledge and experience of the equipment. This will enable them to detect defects and weaknesses and to assess their importance in relation to the safety and continued use of the equipment. It is essential that the Competent Person is sufficiently independent and impartial to allow objective decisions to be made.

2 SPECIFICATION FROG-3

2.1 Specification Summary

Model No.	FS-01 (320) Standard, FS-01 (340) Artic , FS-01 (370) Tropical	
Payload	<p>The Safe Working Load (SWL) of the Frog 3 is the total load of passengers and luggage. SWL = 330 Kg(727 lbs).</p> <p>The Allowable Passenger Load of the Frog 3 is the total passenger load to be placed on the seats. APL = 270Kg (594 lbs)</p> <p>Background: The safe working load (SWL) is relevant to the selection of lifting apparatus and the approach to periodically testing the unit to ensure integrity. The passenger load is important, as this defines the 'moving mass' for which the design of the Frog 3 suspension system is matched.</p> <p>Frog 3 design assumes that 3 persons of 90Kg (198 lbs) are loaded onto the seats, equivalent to 270 Kg of 'moving mass'. In addition to this, each passenger carries 20Kg (44lbs) of luggage placed on the floor, 60 Kg of 'static mass'. The combined load is the SWL of 330 Kgs (727 lbs).</p> <p>Or</p> <p>1 person seated & 1 person in stretcher</p>	
Dimensions		
	Width 1	2200 mm
	Width 2	2500 mm
	Height	2900 mm
Weight		
	Max Gross Weight	815 kg (1796 lb)
	Tare Weight	485 kg (1069 lb)
Manufacture	To ISO 9001:2008	
Materials		
	Frame	SS 316 and A4 Stainless Steel
	Central Column / Lift Eye	Grade 316 Stainless Steel
	Lift Eye Connection Bolts	A4 Stainless Steel
	Other Steel Components	SS 316 and A4 or A2 and Mild Steel Hot Dipped Galvanise
	Buoyancy	Rotationally moulded MDPE shell with PU foam fill
	Seats	GRP
Operating Temperatures		
	Standard Model FS-01 (320)	+50 deg C to -20 deg C
	Arctic Model FS -01 (340)	+50 deg C to -40 deg C
	Tropical Model FS-01 (370)	+50 deg C to +20 deg C

Suspension	
Springs	1 x 8,612 N @ 0.32 m
Dampers	None

2.2 Design

Verification	<p>EC Type Examination. ABS Design and Manufacturing Assessment Design review by independent certifying authority Bureau Veritas. Manufactured to ISO 9001:2008.</p>
National Technical Standards	<p>UK, BS449: Part2:1969: The Use of Structural Steel in Building. UK, BS2830:1994: Suspended Chairs and Cradles for the use in the Construction Industry.</p>
Industry European Standards	<p>EC Machinery Directive. EN 1050, EN292 Parts 1 & 2. Load Test – ILO152 / LOLER.</p>
National Regulations	<p>UK, PUWER / LOLER.</p>
Impact Behaviour	<p>The seating assembly is suspended on a spring assembly designed to protect passengers from impacts up to 4 m/s. This has been verified in full impact testing.</p>
Other Features	<p>Full height bucket seating. Quick release seat harness buckle. Full harness ensures passengers are secure. Grab handles. Stretcher protective frame and support base. Secondary back-up slinging. Angle of stability – 35 degrees (1-3 passengers).</p>

2.3 Certification and Documentation

Each new build of the FROG-3 is supplied with a set of certification and documentation as specified below.

<p>Certification Pack (includes the following)</p>	<p>EC Declaration of Conformity.* Manufacturers Certificate of Conformance. Manufacturers BS EN ISO 9001:2008 Certificate. FROG-3 Load Test Certificate. Sling set Load Test Certificate. Back-up Eye Material Certificate. Lifting Plug Material Certificate. M16 Lifting Plug Bolts Material Certificate. Seat Harness Certificate of Conformance. 3rd Party Inspection Checklist. 3rd Party Inspection Release Note. 3rd Party Inspection BS EN ISO 9001: 2008 Certificate.</p> <p><small>*Note: For CE marked FROGs the EC Declaration of Conformity and the User Manual will be translated into language of the country (EC Member state) in which the machinery is to be used.</small></p> <p><small>This manual makes reference to CE marking of the FROG-3, however there are a limited number of FROG-3's previously supplied without CE marking. The FROG-3 units with the CE Declaration of Conformity are identified with a CE marking plate (see Appendix D). For non-CE marked units please disregard all references to CE marking in this manual.</small></p>
<p>User Manual</p>	<p>1 x User Manual</p>
<p>Additional</p>	<p>Reflex Marine Ltd will retain copies of the above certification and additional certification as specified below. If required, the applicable certification below can be made available for review by clients.</p> <p>Material Certification for all Critical and Non-critical Components. Inspection and Repair History. Weld Procedures / Welder Qualifications. NDT approval (PCN / NDT Reports) (where applicable). Manufacturing Signed Checklist and Route Cards.</p>

3 OPERATING PARAMETERS



3.1 Introduction

The FROG-3 has been designed to ensure passenger safety even when operating in the most demanding conditions.

There are a large number of factors that affect the safe conduct of all marine personnel transfers. These include: crew skill and experience, met-ocean conditions, landing area, vessel station keeping capability and response to sea conditions, visibility, line of sight, etc. A combination of many factors will determine the risk involved in a transfer:

Vertical impacts

Passengers are protected during heavy landings at speeds of up to 4.0 m/s (13.1 ft/s) by the properties of the feet, frame and spring-mounted seat base. These protect passengers up to currently recommended operating limits as detailed in Section 3.2; Table 1.

Lateral impacts

Passengers are also protected from lateral impacts by the framework and seat harnesses. Lateral impacts are only likely to arise due to sway caused by off-lead when lifting and fast slewing. The passengers will be protected up to the 2 m/s (6.5 ft/s) maximum expected impact speed. The central column may deform on lateral impact and there may be damage to other components and therefore the equipment must be inspected after any impact.

Stability

The unit has a low centre of gravity and a tripod base, providing stability on uneven surfaces or on a pitching / rolling vessel. The polyurethane coated landing feet are also a non-skid design keeping grip on deck surfaces. The static angle of stability has been tested to 35 degrees, for a load of 1-3 passengers.

Control of Hoist Line

The FROG-3 is designed to stay firmly on the deck of the transfer vessel whilst passengers are entering or leaving the capsule. The Crane Operator must maintain slack in the line upon landing to allow for the vessel movement. The recommended limits in this section are based on the use of the standard FROG-3 sling length of 30 ft. (9 m). For the use of shorter slings an additional risk assessment combined with dry runs should be performed to establish safe operational routines and weather conditions. (See Section [5.4 Crane Operator Guidance](#)).

It is important that all environmental and operational factors are taken into account in the pre-transfer risk assessment. Assessing the impact of these factors on operational risk must be done by Competent Personnel experienced in use of the equipment and the local conditions.

3.2 Operating Parameters - Sea State



The FROG-3 has an inbuilt damping system which prevents passengers from experiencing shock loads up to relative landing and take-off velocities of 4 m/s (13.1 ft/s). A maximum recommended sea state, or significant wave height, for the operation of the FROG-3 is determined by the maximum relative velocity between the FROG-3 (or hook) and the landing deck.

The calculation for relative velocity used here is based on the European offshore crane standard, EN 13852-1:2004. Whereby the maximum anticipated relative velocity between a load and a vessel deck, is given by the following;

$$\text{Relative velocity} = \text{Hook velocity}^* + \sqrt{(\text{Vessel deck velocity}^2 + \text{Boom tip velocity}^2)}$$

** Equal to 1.67 m/s (100 m/min, 330 ft/min) for lifts below 5 tonnes. Higher crane hook speeds may be available, and it follows that the higher the available crane speed the higher the possibility of a heavy landing or take off. However, with a qualified Crane Operator, it is considered unlikely that the FROG-3 will be landed at full hook speed on a deck rising at full speed.*

If there are concerns about heavy landings, operators may wish to consider the following methods to reduce risk of heavy landings and take-off; dry runs without passengers, landing in centre of deck where less vessel movement, transfer of fewer passengers to increase damping, hook speed indicator.

Table 1: Recommended Sea States for FROG-3

Sig. Wave Height (m / ft)	Max. Wave Height (m / ft)	Fixed Platform to Vessel	Semi-Sub to Vessel	FPSO to Vessel	Vessel to Vessel
≤ 1.0 m / 3 ft	≤ 1.9 m / 6 ft	●	●	●	●
≤ 1.5 m / 5 ft	≤ 2.8 m / 9 ft	●	●	●	◆
≤ 2.0 m / 7 ft	≤ 3.7 m / 12 ft	●	●	●	■
≤ 2.5 m / 8 ft	≤ 4.6 m / 15 ft	●	●	◆	■
≤ 3.0 m / 10 ft	≤ 5.6 m / 18 ft	●	●	◆	■
≤ 3.5 m / 11 ft	≤ 6.5 m / 21 ft	●	◆	■	■
≤ 4.0 m / 13 ft	≤ 7.5 m / 24 ft	◆	◆	■	■
≤ 4.5 m / 15 ft	≤ 8.4 m / 28 ft	◆	■	■	■
≤ 5.0 m / 16 ft	≤ 9.3 m / 30 ft	◆	■	■	■
≤ 5.5 m / 18 ft	≤ 10.2 m / 33 ft	■	■	■	■

KEY	
●	Low risk of high landing or take-off velocity and exceeding FROG-3 personnel damping.
◆	Increasing risk of high landing or take-off velocity. Consideration of hook speed and all other factors is recommended to ensure controlled landing and take-off. A dry run to gauge risk (without personnel) is also recommended.
■	High risk of high landing or take-off velocity. Not suitable for routine operations unless a specific hazard analysis can demonstrate otherwise.

In all cases, adequate planning and risk assessment must be performed.

3.2.1 Site Specific Frog Transfer Operating Parameters

The operating parameters recommended above are based on the calculation method extracted from EN 13852 Offshore Crane Standard and uses data representative of the North Sea. The chart also assumes the Frog is loaded with the maximum allowable passenger load (APL). Operators may develop site specific parameters with an evaluation of relative velocity. Such a study should consider the motion behaviour of the offshore installation, the offshore crane and the supply vessel. Further considerations may be given to the effects of shock absorbers, motion compensators and lee-side effect where sea state is reduced. Such localised conditions may also be taken into account.

It is ALWAYS advised that for personnel transfer in marginal sea states, a dry-run without passengers must be performed to verify the parameters are suitable for safe transfer.

In the event an Operator deduces site specific operating parameters, these must be carefully embedded into the operating procedures in use and well communicated to all parties involved in the transfer.

3.3 Operating Parameters - Additional Factors

Note 1: *It is emphasised that users must not rely on these recommendations alone. Persons best placed to judge the risk of specific transfers are the onsite personnel that have experience of the local conditions and equipment to be used. All factors must be evaluated together in their pre-transfer risk assessment.*

Note 2: *Crews must conduct dry runs without passengers if there are any concerns about conditions to help assess risk of transfer.*

Table 2: Other Operating Parameters

Parameter	Recommendation
Wind Speed	40 knot (equivalent to 20 m/s). The FROG-3 is very stable in high wind. Limiting factor is usually crane operability or control of load.
Visibility	Crane Operator should have a clear view of the pickup and set down areas.
Vessel Motion / FROG-3 Stability	Pitch 10°, Roll 10°. (FROG-3 stable up to 35° for a load of 1-3 Passengers in static test).
Vessel Station-Keeping	Able to maintain position within a 5 m (15 ft) radius. If a high risk of the vessel losing position exists, recommend disconnecting FROG-3 for passenger embarkation.
Landing Area	Clear of obstructions, protrusions, trip and fall hazards.
Landing Area – Ice / Spills	Ice and spills must be cleaned from landing area prior to transfer.
Landing Area on Vessel	The FROG is 2179mm x 2516mm and RML recommends keeping ample space around the unit for embarkation/disembarkation (1m entry and exit path). Operators should take into consideration sea state, weather, vessel station keeping. A risk assessment should be carried out by the operator but a clear space of 6m x 6m is preferable.
Landing Area on Installation	Recommended minimum 4.0 m x 4.0 m clear space (13 ft x 13 ft) based on + 1 m entry and exit path all-round the FROG-3.
Crane Operator Experience	Briefing video within 1 month. Local authority requirements for personnel transfer must be adhered to.
Deck Crew Experience	Briefing video within 1 month.
Passenger Training	Briefing video within 1 month.
Communications	Radio communication must be established between the Crane Operator and the vessel Deck Crew and Master.
Crane Construction	Crane must be certified for lifting personnel and properly maintained.
Operating Temperature	Standard FS-01 -320 Units: +50 deg C to -20 deg C. Arctic FS-01 (340) Units: +50 deg C to -40 deg C. Tropical FS-01 (370) Units : +50 deg C to + 20 deg C

4 TRANSFER PLANNING

The key to safe operations is the familiarisation and participation of all the involved crew in the careful planning of the operation.

The Operating Parameters detailed within this document are generic, therefore safe operating conditions must be determined by onsite supervision with due regard to site specific equipment, vessels and conditions, taking account of any local conditions and equipment.

Safe transfers require careful planning and supervision.

The following are recommended as a means of ensuring safe transfer operations:

4.1 Risk Assessment and Method Statement

A risk assessment and method statement should be completed by the responsible authority on board the installation and by the transfer vessel Captain prior to the first transfer operation for the specific installation and vessel. The risk assessment should be reviewed periodically and the method statement amended in the event of any substantive changes to equipment, procedures or any other factors considered relevant.

4.2 Communications

Communications are an important part of controlling transfer operations. Local communication practice will vary from work group to work group. However, dedicated 3-way radio communication channels must, as a minimum, be provided between the Crane Operator, vessel Master, and Lift Supervisor. A suitable radio protocol must be agreed and adhered to. Contingency communications using a loud speaker or deck tannoy must be available.

Standard hand signals must be used by Crane Banksmen, where required, to supplement the agreed radio communications.

4.3 Information Exchange

The following transfer vessel information must be provided to the installation:

- i. General layout including the landing area position.
- ii. Limiting environmental parameters for vessel station keeping.
- iii. Onboard marine personnel transfer procedures.

The following installation information must be provided to the transfer vessel:

- i. Crane position and hoist speed.
- ii. General layout including the landing area position.
- iii. Limiting environmental parameters for crane operations.
- iv. Onboard marine personnel transfer procedures including responsible persons.
- v. Communications channels.
- vi. Any relevant information regarding local currents, field operations etc.

4.4 Operational Planning

An overall plan must be in place for the proposed personnel transfer operation which details all of the relevant information:

- i. Installation name.
- ii. Vessel name.
- iii. Number of personnel to be transferred - vessel to installation.
- iv. Number of personnel to be transferred - installation to vessel.
- v. Key personnel on installation.
- vi. Key personnel on vessel.
- vii. Installation crane to be used.
- viii. Crane hoist speed.
- ix. Requirements for visual inspections of equipment.
- x. Vessel position and station keeping limits.
- xi. Environmental limits.
- xii. Current and forecast weather conditions.
- xiii. Checklists to be used.

4.5 Briefings

Ensure that passengers and crews (both installation and vessel) are fully briefed prior to an operation. It is recommended that video briefings are utilised for briefing transfer passengers supplemented as necessary by verbal briefing on any relevant installation / vessel specific information.

4.6 Supervision

All transfer operations must be properly supervised. All personnel directly involved in the transfer operation should be appropriately qualified and experienced.

4.7 Transfer Log

Operational records must be maintained by both the installation and the vessel. Records must include:

- i. Time of vessel in position.
- ii. Time of checklists completed.
- iii. Time of commencement of transfer operations.
- iv. Weather conditions.
- v. Vessel motion (roll, pitch and heave).
- vi. Any special conditions or circumstances.
- vii. Number of passengers transferred to installation.
- viii. Number of passengers transferred to vessel.
- ix. Time of completion of transfer operation / vessel clear of installation.
- x. Name of the Lift Supervisor.

An example transfer log is included in [Appendix A](#) of this document.

4.8 Emergency Transfers

If a transfer must be carried out in poor conditions in an emergency then (where time permits) a 'trial run' must be performed without passengers to assess operating conditions and limits.

4.9 Training

Regular transfer drills must be carried out. RML recommend weekly training drills.

4.10 Night Time Operations

With the following controls in place it may be allowable for personnel transfers using the FROG Personnel Transfer Capsule to take place during the hours of darkness:

- i. The risk assessment for the task shall be comprehensively reviewed prior to commencing operations. The lifting plan and risk assessment shall be approved in writing by the Offshore Installation Manager or appointed deputy.
- ii. The operator should have contingency to immediately rescue the passengers from the water e.g. Fast Rescue Craft. Without fast rescue contingency personnel transfers should not take place.
- iii. The crane boom should be fitted with adequate floodlights to illuminate the crane hook and FROG unit. The Crane Operator must maintain a clear line of view with the FROG unit at all times.
- iv. The take-off and landing areas should be illuminated to a level of at least 20 lux or greater.
- v. The FROG unit should be fitted with a strobe light to allow clear locating by all parties.
- vi. The hoisting, transit and landing paths of the FROG unit should be predefined in the lifting plan and are adhered to.
- vii. Radio contact should be maintained throughout the entire lifting operation between the Crane Operator and the take-off and landing site.
- viii. An unmanned trial run which covers, as a minimum, the take-off, transit and landing paths of the FROG should be conducted prior to commencing personnel transfers. The Crane Operator should confirm readiness to proceed on completion of the trial run.
- ix. A non-visual based method of communicating with the lifted personnel should be in place, e.g. radio or loudhailer, in the event of an emergency.

5 OPERATING PROCEDURE



5.1 Pre-Transfer Activity List

Activity No.	Responsible	Activity
1	Supervisor	Conduct pre-transfer risk analysis (See Section 3 and Section 4).
2	Supervisor	Conduct pre-operational 'Visual Check' of equipment (See Section 6.4).
3	Supervisor	Brief all persons; i) Crane Operator, ii) Deck Crew, iii) Passengers, iv) Vessel – Master and Deck Crew.
4	Passengers	Don recommended PPE (Personal Protective Equipment), PFD (Personal Flotation Device) and survival suit (as required and where applicable). <i>Note: Send PFD to vessel prior to transfer</i>

5.2 Lifting

Activity No.	Responsible	Activity
1	Deck Crew	Hook-up masterlink*. Check that harnesses are slacked ready for passengers.
2	Supervisor	Signal to passengers to enter capsule when safe to do so. Ensure even load distribution and that passenger load does not exceed 270 Kg and that passenger & luggage load combined does not exceed 330 kg (See Section 5.6).
3	Passengers	Ensure any loose items are secure.
4	Passengers	Strap-in, do not rush, loosen belt, tighten lower straps, then upper straps.
5	Passengers	Signal to deck crew when seat belt secure by holding hand up / thumbs up.
6	Deck Crew	Ensure passengers are strapped in and hands and feet are correctly positioned.
7	Deck Crew	Ensure taglines (if used) and sling are not snagged.
8	Deck Crew	Stand clear.
9	Supervisor	Signal lift to Crane Operator.

5.3 Landing

Activity No.	Responsible	Activity
1	Crane Operator	All raising and lowering must be over water.
2	Crane Operator	Guide capsule into clear landing area.
3	Deck Crew	Keep safe position if handling unit - do not stand under or between FROG-3 and rail.
4	Deck Crew	If taglines are used beware of specific risks.
5	Crane Operator	Release slack when FROG-3 has landed (See Section 5.4).
6	Crane Operator	Place sling down-wind of unit to prevent hindering access.
7	Deck Crew	Ensure sling slack is not a hazard for exiting passengers.*
8	Supervisor	When FROG-3 is securely on deck, signal "All Clear" to passengers.
9	Passengers	Remain seated until given "All Clear" by the Supervisor.
10	Passengers	Exit capsule and move away towards safe area.

* Note - If risk of vessel losing position or crane line snatch (e.g. vessel to vessel transfers) the FROG-3 must be disconnected for passenger exit and entry.

5.4 Crane Operator Guidance

When landing the FROG-3 on the deck of a heaving vessel the Crane Operator must always release and maintain line slack to prevent any snatching. This means the FROG-3 will be secure on the deck and will provide occupants plenty of time to enter and exit the FROG-3. (This landing procedure is different to the rope basket procedure, which requires the Crane Operator to maintain tension on the hoist to keep the soft rope basket upright during entry and exit).

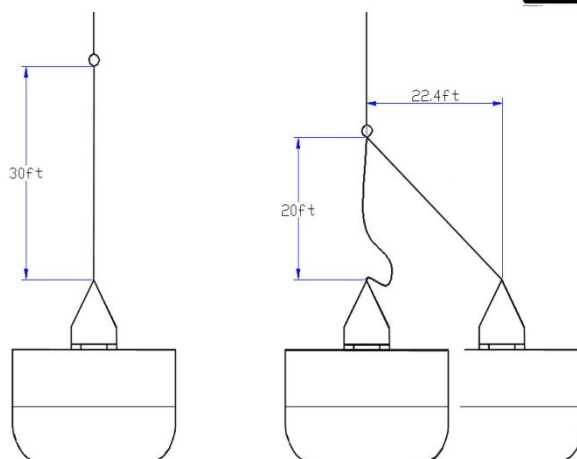

Fig 1: Sling Diagram

For the standard 30 ft / 9 m sling provided with the FROG-3, it is generally recommended that approximately 10 ft / 3 m of slack is paid out once the unit has landed on the vessel. However, the required amount may vary according to sea state and vessel motion response. The Crane Operator must pay out sufficient slack to avoid snatching, although, must avoid paying out more than is necessary as the section of sling hanging could constitute a hazard to crews alighting or entering the capsule.

It is also recommended that the Crane Operator slews the boom 'down weather' from the capsule. This will provide more time for the Crane Operator / crews to react in the event of a failure of the vessel's station keeping.

5.4.1 Use of Shorter Slings

Reflex Marine Ltd recommends the use of a 30 ft / 9 m sling, however for operations where the 30 ft sling is not suitable then a 20 ft / 6 m or 10 ft / 3 m sling can be supplied.

It must be noted that using shorter slings increases the risk of snatching. Using the 20 ft / 6 m sling, 10 ft / 3m of slack will provide a 17.3 ft / 5.3 m allowable offset before the sling becomes taught from the crane hook weight – this does not however account for vessel heave. For a 10 ft / 3 m sling, 8 ft / 2.4 m of slack will provide 9.8 ft / 2.7 m (allowable offset).

Using a shorter sling set also increases risks associated with the hook block being in close proximity to the passengers alighting.

Note: The operating parameters in Section 3.2 are defined for a FROG-3 with a sling length of 30 ft / 9 m. For transfers using a shorter sling an additional risk assessment combined with dry runs should be performed to establish safe operation routines and weather conditions.

5.4.2 Sling Leg Arrangement and Observed Snagging Issue

The FROG-3 sling arrangement has a shorter PRIMARY leg attached to the main lift eye and a longer SECONDARY leg attached to the back-up eye (as shown in drawings 320-B sheet 1 and 220-30-A in [Appendix B](#)).

This arrangement provides lifting redundancy. One issue that has been observed is that on rare occasions the shackle attached to the back-up eye does not always rotate smoothly and can cause an unexpected 'jump' on pick up. This is not a cause for concern but can be alleviated in the following way.

Always ensure the shackle insert (p/n 220-10-03) is always installed correctly onto the shackle pin installed on the back up (longer leg) of the lifting assembly. This part assembly is shown in Detail D of drawing 220-3-A in [Appendix B](#). The shackle pin insert prevents the shackle from assuming a contorted position which could result in a foreshortening of the back up leg.

Always ensure the main shackle retaining bracket (p/n 220-10-05-A) is properly installed when making up the main lift shackle to the lift eye plug. This part assembly is shown in Detail E of drawing 220-3-A in [Appendix B](#). The purpose of this retaining bracket is to present the main shackle in an upward and 'ready for lift' orientation. It is possible that this bracket gets distorted in use and can cause subsequent damage to the sling thimble. It is recommended to also keep a few spare brackets available for easy replacement as required.

5.5 Use of Tag Lines



Tag lines (Hand Lines) are not supplied with the FROG. However if users wish to use tag lines for handling the FROG the following should be considered:

Tag lines should be attached to the floor grating and 30 x 30 brace at the edge of the doorway (see below). Reflex Marine Ltd suggest one or two 3 m lines are practicable for handling the FROG, however length of line used is at the discretion of the deck crew.

Be aware of specific risks arising from use of tag lines:

- i. Deck Crew using Tag lines will be standing closer to frog during landing, which increases the risk of impact or being caught in between.
- ii. Ensure Tag lines are not tied or caught on any adjacent equipment or structures.
- iii. Ensure Tag lines are clear of knotting and deck crew have suitable hand and eye protection.

5.6 Seating and Load Distribution

In order to perform loading efficiently and safely, the following procedures are recommended:

- i. Organise passengers into groups of 3 (see note*).
- ii. Confirm that passenger and luggage weight combined does not exceed the SWL of the FROG-3 unit: 330 kg (or 3 x 110 kg).
- iii. Confirm the passenger weight does not exceed the maximum allowable passenger weight of 270 Kg. (3 * 90 Kg).
- iv. Load the Group 1 (1, 2 and 3) into the seats as shown.

**Note - When the FROG-3 is used for less than 3 passengers, the unit will remain well balanced.*

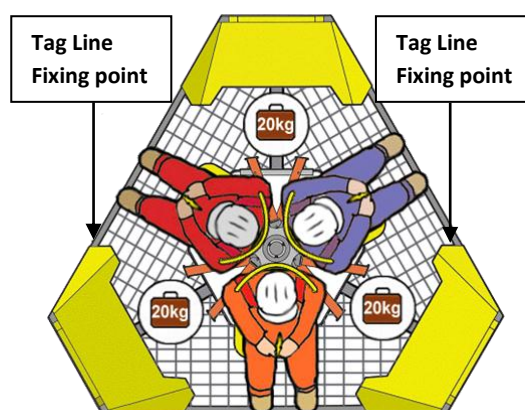

Fig 2: Seat Loading and Tag Line Fixing Points

5.7 Luggage Storage

The FROG-3 is supplied with three luggage storage nets that are located in the corners of the FROG-3 against the lower buoyancy blocks. These provide a pocket in which luggage can be stored (see photo). All luggage items should be stored in the corners so that they do not constitute a tripping hazard for passengers exiting the FROG-3.

Each passenger is permitted a **maximum** of 20 kg hand luggage. The nets are constructed of elastic shock-cord (or bungee) and will stretch to contain items of size in the order of 600 mm x 500 mm. Items of luggage too large for the nets should be transferred as a separate lift.

The floor grating is spaced at 25 mm x 50 mm. Small items, therefore, should be bagged to prevent items falling through the floor and constituting a dropped object hazard.



Fig 3: FROG-3 Luggage Storage

5.8 Seatbelt Operation

Take the lap fastener clip and feed through eye. Fold over the clip and the safety belt is secure. Reverse operation for quick release.



Fig 4: Fastening the Belt

Next pull the LOWER straps first, then the UPPER straps to make a tight fit.



Fig 5: Tightening the Belt

5.9 Rider Instructions

- i. Keep hands and feet inside the FROG-3.
- ii. Hold the grab handles to keep the body stabilised.
- iii. Keep feet inside the FROG-3 at all times.
- iv. Do not hook legs underneath the suspended seats.



Fig 6: Position of Body

5.10 Emergency Stop Procedure

In the event of an emergency situation the Deck Supervisor / Banksman will give the Crane Operator the emergency stop signal.

- i. Crane Operator must stop all movements.
- ii. The Deck Supervisor / Banksman will shout "OUT OUT OUT".
- iii. Personnel to release seat belt buckles and vacate FROG.
- iv. Deck Supervisor / Banksman will direct passengers to a safe area.

UK Emergency STOP signal

Both arms pointing upwards with palms facing forwards



US / API Emergency STOP signal

Both arms extended, palms pointing down, move arms rapidly back and forth horizontally

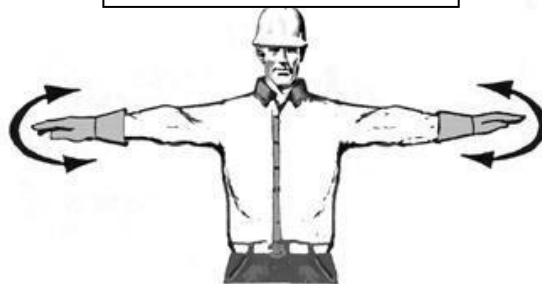

Images sources:

UK Image: UK HSE: Workplace transport safety-an employers' guide (HSG136); Reproduced under the terms of the click-use licence. USA Image: Used with the kind permission of the National Commission for the Certification of Crane Operators (NCCCO). All rights reserved.

5.11 Personal Protective Equipment (PPE)





Whilst making the transfer, all personnel must be equipped with appropriate Personal Protective Equipment. Each location and transfer activity will demand a range of differing levels of PPE and RML recommend that PPE requirements are evaluated in recognition of the particular activity and environmental risks that exist at each location. Some items for consideration whilst establishing PPE are:

- i. Survival rates in water (summer and winter).
- ii. Wind temperature ranges.
- iii. Proximity of overboard rescue facility, fast rescue boat (FRB), standby vessels.
- iv. Deployment time and personnel capacity of each rescue craft.
- v. Drill timings and multiple casualty scenarios.
- vi. Routine and non-routine offshore activities that might provide source of risk.

The Operator must decide the recommended minimum standard for personal protective equipment requirement according to local conditions, regulations, standards and individual activity risk assessments.

5.11.1 Personal Flotation Devices (PFD's)

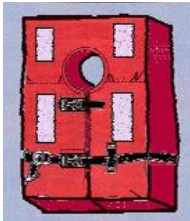
Reflex Marine Ltd has evaluated the 5 most common types of PFD's used in the offshore and marine sector and has the following comments about their suitability for use with the FROG.

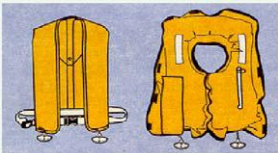
Style / Type	Picture	Evaluation	Recommendation
Inherently buoyant work vest buoyancy aid (100 N)		Flat buoyancy panels are unobtrusive and allow passengers easy entry and exit from seat harness.	Acceptable RML recommend that any PFD of this type is tested with seat harness in FROG for compatibility.
Manual inflatable lifejacket (150 N)		Inflation toggles may interfere with seat harness creating risk that PFD may inflate when person is strapped in. Personnel should be informed that PFD should not be inflated when person is strapped in the FROG.	Acceptable (exception basis) RML recommend that this style is used carefully to prevent accidental inflation.
Inherently buoyant 'yoke' type lifejacket (100-150 N)		This type of PFD is bulky and may prove restrictive when donning seat harness. PFD generally has a poor fit with seat harness, particularly over shoulders. Seat harness buckle release mechanism may become positioned underneath PFD out of line-of-sight of passenger, making exit more difficult.	Not acceptable
Offshore work vest buoyancy aid (50 N)		This PFD may be ineffective for passengers with heavy clothing.	Not acceptable
Automatic inflatable lifejacket (Contact with water)		Risk that PFD may inflate when person is strapped in and FROG is immersed which may impede passengers exit for rescue.	Not acceptable

Additional Considerations:

- i. Reflex Marine Ltd recommend that a number of PFD's, specifically designated for use with the FROG, are marked as 'FROG USE ONLY' and are kept in a safe, clean storage area near the transfer muster area.
- ii. It is recommended that 3 sets (+ 10% spares) of PFD's are made available for the transfer activity:

- 1 set for uplift transfers (ready and donned).
- 1 set for down lift transfers (ready and donned).
- 1 set for in-transit for next uplift transfers.

Total PFD requirement for FROG-3 = $3 \times 3 + 1 = 10$ PFD's.

- iii. Deck crew should ensure that when passengers are exiting the FROG, the passengers move clear of the landing area to the designated safe area before removing PFD's.
- iv. Passengers using the PFDs for the first time should be given assistance by the deck crew. PFD's should be tried by all crew as part of any practical training given.

5.11.2 Immersion Suits

Full immersion suits may be required in certain situations. Reflex Marine Ltd recommends that risk assessments are performed to determine whether immersion suits are to be used. We are happy to advise previous experience with use in conjunction with the Frog.

5.12 Stretcher Mode

5.12.1 Converting FROG-3 to Stretcher Mode (Figure 7)

It is recommended that the procedure be conducted by two or three persons. This is to ease handling of the lower buoyancy blocks which weigh approximately 20 kg. The procedure should not be conducted over grated flooring to prevent the risk of small fittings falling through the floor. The procedure should be conducted with a clear area around FROG-3 to provide space for realignment of the buoyancy units.

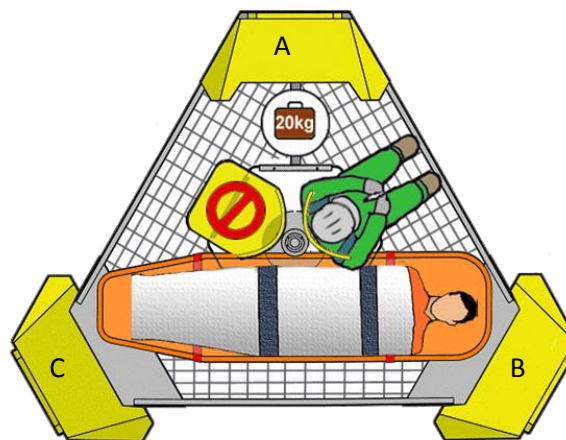

Figure 7: Stretcher Mode Arrangement

Tools Required

- i. 6 mm Hex Key (for M10 bolts - Seat, Stretcher Frame).
- ii. 8 mm Hex Key (for M12 bolts - Buoyancy).
- iii. 17 mm Wrench (for M10 bolts - Seat).
- iv. 19 mm Wrench (for M12 bolts - Luggage Box).
- v. Box / Bag for Loose Fittings.
- vi. FROG-3 Diagrams.

5.12.2 Stretcher Mode Conversion Procedure

- i. Refer to Figure 8: Buoyancy Reconfiguration Diagram.
- ii. If the optional luggage box has been fitted (see [Appendix E](#)) unscrew the 4 x M12 Hex Bolts and remove from the lower buoyancy.
- iii. Luggage nets may remain in place to speed up the conversion or remove to store.
- iv. Remove the bolts (4 x M12 Dome Cap) and spacers from lower buoyancy blocks B and C.
Note: The latest FROGs do not have spacers P/N F-01-048 between the lower buoyancy modules and the frame.
- v. Fix lower buoyancy units B and C to outside of unit. Tighten the M12 dome cap bolts to hand tight with hex key (Max 18 NM).

Note: Over-tightening of these bolts can lead to damaged buoyancy.

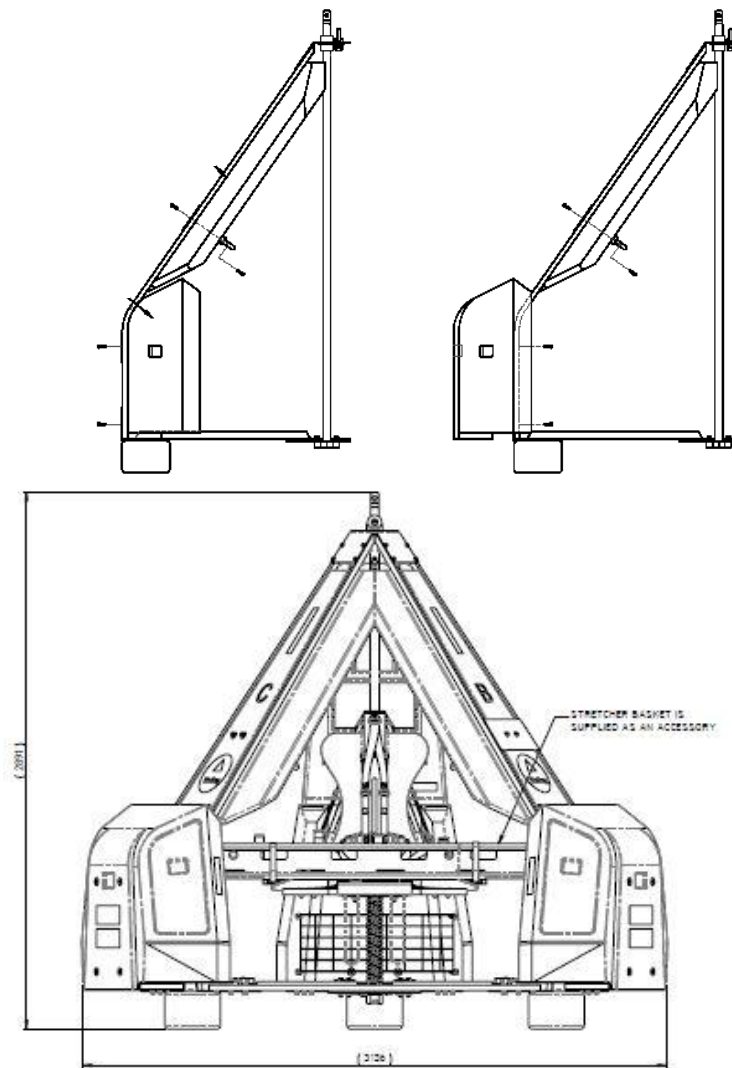

Figure 8: Buoyancy Reconfiguration Diagram

- vi. Refer to Figure 9: Stretcher Fitting Diagram.
- vii. Remove the lower fixing bolts (2 x M10 Dome Cap) from seat facing door B - C.
- viii. Loosen the upper fixing bolt (1 x M10 Dome Cap) and loosen the nut from seat facing door B - C. The seat can be removed once the bolt head is passed through the key-slot.
- ix. Seat harness can now be fastened behind the central column to provide a clear area for the stretcher frame.
- x. Position the stretcher frame on the seat base. Align the tab with the hole on circular plate and fix with M10 dome cap bolt and wing nut.

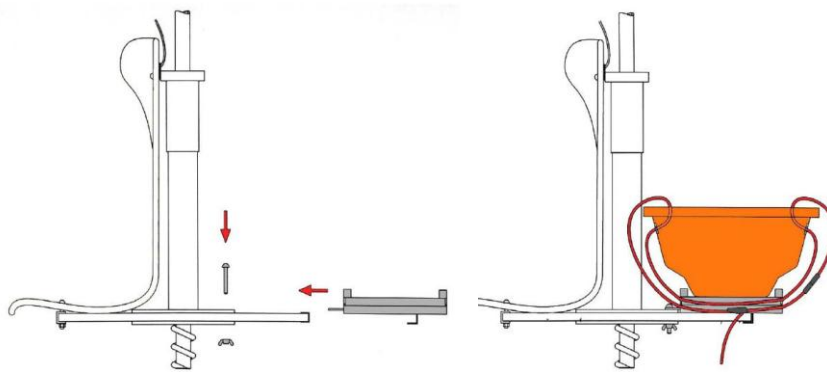

Figure 9: Stretcher Fitting Diagram

5.12.3 Positioning the Stretcher

- i. Complete the 'Converting to Stretcher Mode' procedure.
- ii. Ensure the stretcher casualty is securely strapped into the stretcher.
- iii. Using three persons to lift the stretcher (two either side at shoulders, one at feet), move stretcher head first through door B - C (door opening with stretcher frame)
Note: Observe safe manual handling practice when lifting the stretcher.
- iv. Place the head-end of the stretcher on to the stretcher frame and slide the stretcher into position as per Figure 7: Stretcher Mode Arrangement.
- v. An intravenous drip may be placed on the hook* on the central column. (*where fitted)
- vi. Secure the stretcher in position with the two straps provided as shown in Figure 9 Stretcher Fitting Diagram:
 - a. Begin by feeding the fork end of the strap through eyelets on the stretcher frame then through closest handles of the stretcher and continue around through to the second stretcher handle.
 - b. Fasten underneath.
 - c. Ensure the stretcher is secure.
- vii. Only one passenger should accompany the casualty.

5.12.4 3-Seat Mode Conversion Procedure

- i. Refitting the seat is the reverse of the conversion to stretcher mode.
- ii. Tighten the fittings for the lower buoyancy unit and the seat to **low torque hand tight only (18 NM)**. Over-tightening of these bolts can lead to damage to the buoyancy inserts or to the seat.

5.12.5 Stretcher (Optional) Accessory

Reflex Marine Ltd provides an optional basket type stretcher as illustrated in Figure 10.



Figure 10: Basket Type Stretcher (optional)

Specifications:

Length	2180 mm	
Width 1	610 mm	
Depth	190 mm	
Weight	10 kg	
Load Limit	275 kg	Includes weight of patient, stretcher and any medical equipment.
Operating Temperature	-40 deg C to +60 deg C	

6 PERIODIC INSPECTION, TESTING AND MAINTENANCE



6.1 Introduction

It is imperative for the safe operation of the FROG-3 that each unit is periodically inspected and tested in accordance with procedures and schedules set out in this section.

6.2 Definitions

Visual Check

A Visual Check is a careful and critical assessment of the components, carried out by a Competent Person without dismantling of the assembly. Normally the check itself is not formally recorded although the fact that the check has been performed is registered within a daily event log or tour log.

Visual Inspection

A Visual Inspection is a careful and critical assessment of the components, carried out by a Competent Person without dismantling of the assembly. The inspection is formally recorded.

Examination

An Examination is a careful and critical assessment of the components, carried out by a Competent Person. This should include dismantling the assembly and performing a visual assessment of the condition of each component, supplemented by other means such as measurement and non-destructive testing as considered necessary. For sling sets this should include a visual inspection of the condition of the sling. In order for end fittings of sling sets to be examined properly, they may need to be dismantled. The examination is formally recorded.

Post Load Test Visual Inspection

A Post Load Test Visual Inspection is a careful and critical assessment of the components, carried out by a Competent Person without dismantling of the assembly post load testing. The post load test visual inspection is formally recorded.

Critical Components

Critical Components are defined as those that are primarily essential to the critical load bearing path.

6.3 Frequency of Inspection, Test and Maintenance



The recommended frequency and type of inspection, test and maintenance is shown in Table 3. (SEE OVER). Please note:

- i. If any doubt exists regarding the number of transfer operations performed then the maintenance strategy must revert to a more conservative higher usage category. This must also be considered if there is any concern over heavy impacts or overloads.
- ii. This recommendation applies to change out of components parts only and does not replace or alter the inspection intervals as prescribed by the relevant legislation.
- iii. The check, inspection, examination and test routine as detailed in this document must always be carried out on schedule.
- iv. Where the FROG has sustained substantial damage, a detailed examination of the unit must be carried out to ensure the integrity of the unit before conducting any further lifts. Details of all damage should be recorded in a Damage Report. Details of the cause of the damage should also be recorded, if known. If damage to the frame has occurred, welds should be examined for cracks using dye penetrant.
- v. Details of all repairs or modifications carried out must be recorded and copies of damage and repair / modifications reports must be sent to the party controlling the use of the FROG-3.
- vi. Reflex Marine Ltd is pleased to provide direct technical advice to support users with any inspection, testing, repair or refurbishment query. It is always helpful if customers provide detailed photos and reports along with their query to support@reflexmarine.com.

Table 3: Inspection and Maintenance Recommendations

(NOTE: RML website www.reflexmarine.com/support should be checked for the latest version of this table)

INSPECTION AND MAINTENANCE RECOMMENDATIONS (FROG-3 & FROG-6 TRANSFER PRODUCTS) Rev 03 - 120501		RECOMMENDED FREQUENCY							
		INSPECTIONS				LOAD TESTS	MAINTENANCE		
		Pre Operational Visual Check	Visual Inspection	Examination	Post Load Test Visual Inspection	Proof Load Test	Sling Replacement	Critical Parts Replacement	Unit Replacement
USAGE CATEGORY		<i>Section 6.4</i>	<i>Section 6.5</i>	<i>Section 6.6</i>	<i>Section 6.7</i>	<i>Section 6.8</i>	<i>Section 6.9</i>	<i>Section 6.10</i>	<i>Section 6.11</i>
Usage Category	No of Transfer Lifts per year		<i>not exceeding</i>	<i>not exceeding (depending on Visual Inspection) this period may be reduced</i>			<i>not exceeding</i>	<i>not exceeding</i>	<i>not exceeding</i>
Very Low	<20	before every use	6 months	12 months	After Load Test	On Critical Parts Replacement	12 months	36 months	10* years
Low	<100	before every use	6 months	12 months	After Load Test	On Critical Parts Replacement	12 months	36 months	8 years
Medium	100 to 500	before every use	6 months	12 months	After Load Test	On Critical Parts Replacement	12 months	24 months	7 years
High	500 to 1500	before every use	3 months	12 months	After Load Test	On Critical Parts Replacement	6 months	12 months	6 years
Very High	1500 to 2500	before every use	3 months	12 months	After Load Test	On Critical Parts Replacement	3 months	12 months	4 years
Ultra High	2500 to 5000	before every use	3 months	6 months	After Load Test	On Critical Parts Replacement	3 months	6 months	3 years

*This may be extended subject to a 'condition & service assessment' carried out by RML (Reflex Marine Ltd) or an ASC (Accredited Service Centre).

6.4 Pre-Operational Visual Check

(NOTE: RML website www.reflexmarine.com/support should be checked for the latest version of the tables in this section)

Question	Response
When must a Visual Check be conducted?	A Visual Check must be conducted PRIOR to EVERY use of the equipment (multiple lifts in one series of transfer operations constitute one usage period).
Who must conduct this check?	A person who has been formally trained to perform this Visual Check and is familiar with this equipment, i.e. a Competent Person.
Does this check require a formal record?	Yes, a record that the visual check has been completed should be recorded appropriately, e.g. an entry in the daily tour record stating date the check has been completed, unit number and any relevant comments.
What drawings are required to support this check?	The drawings are available in Appendix B .
What equipment is required to perform this check?	<ul style="list-style-type: none"> i. A ladder. ii. An inspection frame or floor matting. iii. Good lighting. <p>A suitable means of safely accessing the top and the bottom parts of the FROG-3 is required. When using a step ladder or ladder it must be securely fixed to prevent slippage whilst accessing the top of the FROG. The FROG-3 keel assembly can be visually checked from ground level using a torch. Do not go underneath an active lift.</p> <p>Be aware that in some regions “Working at Height” regulations may apply.</p>

The following checklist is suggested as a suitable list for a 10 POINT PRE-OPERATIONAL CHECK.

Pre-Operational Visual Check – 10 POINT Check

Check	Description	Reference
1.	Main Lift-Eye Plug Check main lifting eye is fully engaged (the machined shoulder should rest on top of the threaded main lifting column).	
2.	Main Lift-Eye Plug M16 Bolts Check two M16 lifting eye bolts, nuts, split pins and tamper proof seals are present and secure.	
3.	Back-Up Lift-Eye Check nut, split pin and tamper proof seal are fitted and in good order.	
4a or 4b	M48 Keel Boss and either Roll Pin or M10 Cross Bolt Check keel boss and either cross bolt or roll pin are in position c/w split pin and tamper proof seals and anti-rotation fittings.	
5.	Frame and Buoyancy Check for any damage and ensure that all bolts and fasteners are present, tight and secure. Do not go underneath an active lift.	
6.	Seat Harness Security Check seat harnesses operate properly and attachment points are secure.	
7.	Inspection Data Plate & Certification Check the date of the last examination/inspection to ensure the unit is in compliance.	
8.	Lifting Sling Set Check slings are correctly attached and in good order. Check the split pins are fitted to shackles. Slings should be in the high visibility cover. Check the anti-fouling bracket and the back-up eye shackle insert are in good condition (see Section 5.4.2).	
9.	Main Seat Spring Check the spring condition and test the operation of the spring.	
10.	Seat Assembly Anti-Rotation Fitting Check the anti-rotation bolt (or the roll-pin) is secure and functioning correctly.	

6.5 Visual Inspection

(NOTE: RML website www.reflexmarine.com/support should be checked for the latest version of the tables in this section)

Question	Response
When must a Visual Inspection be conducted?	A Visual Inspection must be conducted at the recommended frequency in Table 3. This frequency may be as long as every 6 months or as short as every 3 months according to usage.
Who must conduct this inspection?	A Competent Person.
Does this inspection require a formal record?	Yes.
What drawings are required to support this inspection?	The drawings are available in Appendix B .
What equipment is required to perform this inspection?	<ul style="list-style-type: none"> i. A ladder. ii. An inspection frame or floor matting. iii. Good lighting. <p>A suitable means of safely accessing the top and the bottom parts of the FROG-3 is required. When using a step ladder or ladder it must be securely fixed to prevent slippage whilst accessing the top of the FROG. The FROG-3 can be laid on its side on protective matting, or the use of a secure inspection frame assembly to safely access the underside of the FROG-3 is recommended. Do not go underneath an active lift. Be aware that in some regions "Working at Height" regulations may apply.</p>

The following checklist is suggested as a suitable list of required inspection items and a suitable format for recording key inspection data. A 'WORD and EXCEL' copy of this inspection checklist is included on the distributed CD's and is also available on the Reflex Marine Ltd website at www.reflexmarine.com/support.

Visual Inspection Checklist Form

Unit No		This Inspection Date		Inspected by	
Usage Category		Last Inspection Date		Position/ Company	
Installation / Vessel				Signature	
Avg No of Transfers / Year				Original Inspection record filed in	

Item No	Description	Comment	Pass / Fail	Verified By
1.	Main Lift-Eye Plug (Critical Part) Visually inspect in situ for any signs of wear, cracks, deformation or other damage			
2.	Main Lift-Eye Plug M16 Bolts (Critical Part) Visually inspect the two M16 lifting eye bolts, nuts, split pins and tamper proof seals that connect the main lift-eye plug to the central column for wear or damage.			
3.	M48 Keel Boss and M10 Cross Bolt (or roll pin on older models) (Critical Part) At the bottom end of central column, visually inspect the M48 keel boss nut and ensure that the M10 cross bolt (keel plate nut roll pin on older models) is secure c/w split pin & tamperproof seal. Check the presence of anti-rotation fittings and that all bolts are secure. Do not go underneath an active lift.			
4.	Lifting Sling Set (Critical Part) The lifting sling set (including attachments) must be visually examined by a Competent Person. Note: High visibility cover must be completely removed to allow inspection of steel wire rope components. Replace the sling set according to the usage of the FROG (see Table 3 in Section 6.3). This may be as frequently as every 3 months. Irrespective of apparent condition the lifting sling set should be replaced at least every 12 months.	<i>Note serial number and test date stamp (specify decision to retain or replace).</i>		
5.	Sling Anti-Fouling - Check the lifting assembly anti-fouling bracket and shackle spacer (or the anti-fouling tie wraps if an earlier model) are in good condition (see Section 5.4.2). Replace as necessary.			
6.	Backup-Eye - Visually inspect for any wear or damage and check that the split pin and tamper proof seal are intact.			
7.	Main Seat Spring Check The Frog-3 Spring can be susceptible to yield over time. The Frog-3 spring is deemed fit for purpose until it yields beyond 5% in length. This can be verified by measuring the free length of the spring or measuring the deflection of the seat base in-situ. The following checks are recommended to identify whether the spring is fit for purpose: 1. In-situ check The Frog-3 Sliding Sleeve Cross Bolt Runner should rest against the slotted Sliding Sleeve, with a pre-compression force of approximately 60kg. If a space exists between the slot edge and the Cross Bolt Runner greater than 13mm, the Spring should be replaced. 2. Free Length check Free Length of a new Frog-3 Spring is 825mm (+/-16mm). If the Free Length is less than 785mm the Spring should be replaced.			

8.	Sliding Sleeve and Alignment Cross Bolt Inspect the alignment cross bolt, check for any deformation of the bolt. Check that the nylon bushings are in good condition (anti-rotation roll pin on older models) – Note: This is a special high yield strength bolt.			
9.	Landing Feet - Examine the feet to ensure that they are in good condition and that they are properly secured to the capsule. Do not go underneath an active lift. Notes: i. Measure height of foot and replace if under 150 mm in height ii. Small (20 mm in length) cuts are acceptable but feet should be replaced when the internal foam becomes visible			
10.	Seat Base Assembly - Visually inspect for any wear or damage and ensure that all bolts' and other fasteners are fully secure.			
11.	Frame and Buoyancy - Visually inspect for any damage and ensure that all bolts and fasteners are tight and fully secure.			
12.	Seat Harness Security - Visually inspect the seat harness attachment points and the harness webbing for any signs of wear, fraying or damage. Check that attachment points are secure.			
13.	Seat Harnesses (sit-in) -Check all seat harness buckles to ensure each is functioning correctly. (Inspector to sit in each seat and check fastening and unfastening of each harness).			
14.	Inspection Data Plate - Check the date of the last examination/inspection to ensure the unit will remain in compliance with requirements for at least 6 months.			
Storage				
15.	Storage of FROG - Check the storage cover is in good condition and not showing any signs of UV or wind degradation. Storage off the ground , use of spacer chocks whilst not in use			
16.	Replacement Parts Stock - Check condition of all associated replacement parts and accessories. Sling sets should be stored in an appropriate dry place without high visibility cover fitted.			
Reports			Complete Y/N	
17.	Photographic Report - Take the standard set of photos as detailed in the recommended inspection report template. As a minimum photos of each of the 17 points in the check list should be taken.			
18.	Documentation / Report - Complete a report as recommended in the RML inspection template. Reflex Marine Ltd offer to keep an archive copy of your inspection records against the unit number. You can submit your completed checklists and photographs on www.reflexmarine.com/support .			
NOTES:				

6.6 Examination

(NOTE: RML website www.reflexmarine.com/support should be checked for the latest version of the tables in this section)

Question	Response
When should an examination be conducted?	An Examination must be conducted at least EVERY 12 months. According to the findings of any Visual Inspection a more frequent Examination schedule may be warranted according to wear, age of unit and usage conditions. At each Examination it is a good opportunity to replace a small number of critical and other replacement parts and therefore more frequent examinations may be prudent.
Who should conduct this examination?	A Competent Person.
Does this examination require a formal record?	Yes.
What drawings are required to support this examination?	The drawings are available in Appendix B .
What equipment is required to perform this examination?	<ul style="list-style-type: none"> i. A ladder. ii. An inspection frame or floor matting. iii. Good lighting. iv. Appropriate metric tool kit (socket set, combination spanners, allen keys etc). v. Riveter. vi. Inspection data plate (with stamps). vii. Proof load equipment (see Section 6.8). <p>A suitable means of safely accessing the top and the bottom parts of the FROG-3 is required. When using a step ladder or ladder it must be securely fixed to prevent slippage whilst accessing the top of the FROG. The FROG-3 can be laid on its side on protective matting, or the use of a secure inspection frame assembly to safely access the underside of the FROG- 3 is recommended. Do not go underneath an active lift. Be aware that in some regions “Working at Height” regulations may apply.</p>

The following checklist is suggested as a suitable list of required Examination items and a suitable format for recording key Examination data. A ‘WORD and EXCEL’ copy of this Examination checklist is included on the distributed CD’s and is also available on the Reflex Marine Ltd website at www.reflexmarine.com/support.

Examination Checklist Form

Unit No		This Examination Date		Examined by	
Usage Category		Last Inspection Date		Position/ Company	
Installation / Vessel		Last Examination Date		Signature	
Avg No of Transfers / Year		Load test Performed Y/N		Original Inspection record filed in	

Item No	Description	Comment	Pass / Fail	Verified By
1.	<p>Main Lift-Eye Plug (Critical Part) Remove and visually inspect the main lift-eye plug for any signs of damage or strain. Replace according to the usage of the FROG-3 (see Table 3 in Section 6.3) or on the recommendation of a Competent Person / Inspector. (Note: Although RML do not deem as required, some Operators may wish to adopt a dye penetrant crack inspection prior to any re-installation of a critical part.)</p>			
2.	<p>Main Lift-Eye Plug M16 Bolts (Critical Part) Remove and visually inspect the two M16 main lift-eye plug securing bolts for any signs of damage or strain. Visually inspect the two M16 holes in the central column tube for signs of damage or strain. Replace appropriate parts according to the usage of the FROG-3 (see Table 3 in Section 6.3) or on the recommendation of a Competent Person / Inspector. Bolt torque to 134 Nm.</p>			
3.	<p>M48 Keel Boss and M10 Cross Bolt (or roll pin on older models) (Critical Part) Remove the M48 keel boss nut and visually check that the threads at the bottom of the central column tube are in good condition. Before replacing the keel nuts ensure the threads on both the central column and keel nut are thoroughly cleaned so they are free of grime and grit. Both threads should then be coated with either Rocol Anti-Seize Stainless or Swagelok Blue Goop thread lubricant. Do not go underneath an active lift. Replace appropriate parts according to the usage of the FROG-3 (see Table 3 in Section 6.3) or on the recommendation of a Competent Person / Inspector.</p>			
4.	<p>Lifting Sling Set (Critical Part) Replace the sling set according to the usage of the FROG (see Table 3 in Section 6.3). This may be as frequently as every 3 months. Irrespective of apparent condition the lifting sling set should be replaced at least every 12 months. Check the main lifting shackle alignment plate and the back-up eye shackle insert are in good condition (see Section 5.4.2). Replace as necessary.</p>	<i>Note serial number and test date stamp (specify decision to retain or replace).</i>		
5.	<p>Sling Anti-Fouling - Check the lifting assembly anti-fouling bracket and shackle spacer (or the anti-fouling tie wraps if an earlier model) are in good condition (see Section 5.4.2). Replace as necessary.</p>			
6.	<p>Backup-Eye – Inspect the back-up eye in situ, nut, split pin and tamper proof seal. Replace on the recommendation of a Competent Person / Inspector. Torque to 125nm</p>			

7.	<p>Main Seat Spring Check Check the spring condition and test the operation of the spring. If the spring shows excessive corrosion or has started to compress then it should be changed out. The Frog-3 Spring can be susceptible to yield over time. The Frog-3 spring is deemed fit for purpose until it yields beyond 5% in length. This can be verified by measuring the free length of the spring or measuring the deflection of the seat base in-situ. The following checks are recommended to identify whether the spring is fit for purpose:</p> <p>1. In-situ check The Frog-3 Sliding Sleeve Cross Bolt Runner should rest against the slotted Sliding Sleeve, with a pre-compression force of approximately 60kg. If a space exists between the slot edge and the Cross Bolt Runner greater than 13mm, the Spring should be replaced.</p> <p>2. Free Length check Free Length of a new Frog-3 Spring is 825mm (+/-16mm). If the Free Length is less than 785mm the Spring should be replaced.</p>			
8.	<p>Sliding Sleeve and Alignment Cross Bolt Inspect the alignment cross bolt in-situ. Check for any deformation of the bolt or excessive wear on the nylon bushings. Replace with new cross bolt and bushings as required. – <i>Note:</i> This is a special high yield strength bolt.</p>			
9.	<p>Landing Feet - Examine the feet to ensure that they are in good condition and that they are properly secured to the capsule. Do not go underneath an active lift. Notes:</p> <p> iii. Measure height of foot and replace if under 150 mm in height</p> <p> iv. Small (20 mm in length) cuts are acceptable but feet should be replaced when the internal foam becomes visible</p>			
10.	<p>Seat Base Assembly - Visually inspect for any wear or damage and ensure that all bolts’ and other fasteners are fully secure.</p>			
11.	<p>Frame and Buoyancy - Visually inspect for any damage and ensure that all bolts and fasteners are tight and fully secure.</p>			
12.	<p>Seat Harness Security (Critical Part) - Visually inspect the seat harness attachment points and the harness webbing for any signs of wear, fraying or damage. Check that attachment points are secure.</p>			
13.	<p>Seat Harnesses (sit-in) -Check all seat harness buckles to ensure each is functioning correctly. (Inspector to sit in each seat and check fastening and unfastening of each harness).</p>			
14.	<p>Load Test (see Section 6.8) – On critical parts replacement, a load test (see Table 3 in Section 6.3) must be conducted by an independent test house company, nationally recognised and in accordance with ILO 152.</p>			
15.	<p>Inspection Data Plate - Update the inspection data plate after completion of approved examination/inspection.</p>			
16.	<p>Post Load Test Visual Inspection (See Section 6.7) – If load test done, conduct and report a post load test visual inspection.</p>			
	<p>Storage</p>			
17.	<p>Storage of FROG - Check the storage cover is in good condition and not showing any signs of UV or wind degradation. Storage off the ground , use of spacer chocks whilst not in use</p>			

18.	Replacement Parts Stock - Check condition of all associated replacement parts and accessories. Sling sets should be stored in an appropriate dry place without high visibility cover fitted.		
Reports			Complete Y/N
19.	Photographic Report - Take the standard set of photos as detailed in the recommended inspection report template. As a minimum photos of each of the 18 points in the check list should be taken.		
20.	Documentation / Report - Complete a report as recommended in the RML inspection template. Reflex Marine Ltd offer to keep an archive copy of your inspection records against the unit number. You can submit your completed checklists and photographs on www.reflexmarine.com/support .		
NOTES:			

6.7 Post Load Test Visual Inspection

(NOTE: RML website www.reflexmarine.com/support should be checked for the latest version of the tables in this section)

Question	Response
When should a post Load test visual inspection be conducted?	A post load test visual inspection must be conducted immediately following every load test. The load test exerts additional stress into the FROG and this inspection formally records whether any resulting weakness is observed.
Who should conduct this inspection?	A Competent Person.
Does this inspection require a formal record?	Yes.
What drawings are required to support this inspection?	The drawings are available in Appendix B .
What equipment is required to perform this inspection?	<ul style="list-style-type: none"> i. A ladder. ii. An inspection frame or floor matting. iii. Good lighting. <p>A suitable means of safely accessing the top and the bottom parts of the FROG-3 is required. When using a step ladder or ladder it should be securely fixed to prevent slippage whilst accessing the top of the FROG. The FROG-3 can be laid on its side on protective matting, or the use of a secure inspection frame assembly to safely access the underside of the FROG-3 is recommended. Do not go underneath an active lift. Be aware that in some regions “Working at Height” regulations may apply.</p>

The following checklist is suggested as a suitable list of required inspection items and a suitable format for recording key inspection data. A ‘WORD and EXCEL’ copy of this inspection checklist is included on the distributed CD’s and is also available on the Reflex Marine Ltd website at www.reflexmarine.com/support.

Post Load Test Visual Inspection Checklist Form

Unit No		This Inspection Date		Inspected by	
Usage Category		Load Test Date		Position/ Company	
Installation / Vessel		Load Test Report/Ref		Signature	
Avg No of Transfers / Year		Load Test Authority		Original Inspection record filed in	

Item No	Description	Comment	Pass / Fail	Verified By
1.	Main Lift-Eye Plug (Critical Part) Visually inspect in situ for any signs of wear, cracks, deformation or other damage			
2.	Main Lift-Eye Plug M16 Bolts (Critical Part) Visually inspect the two M16 lifting eye bolts, nuts, split pins and tamper proof seals that connect the main lift-eye plug to the central column for wear or damage.			
3.	M48 Keel Boss and M10 Cross Bolt (or roll pin on older models) (Critical Part) At the bottom end of central column, visually inspect the M48 keel boss nut and ensure that the M10 cross bolt (keel plate nut roll pin on older models) is secure c/w split pin & tamperproof seal. Check the presence of anti-rotation fittings and that all bolts are secure. Do not go underneath an active lift.			
4.	Backup-Eye - Visually inspect for any wear or damage and check that the split pin and tamper proof seal are intact.			
5.	Main Seat Spring Check Check the spring condition and test the operation of the spring. 1. In-situ check The Frog-3 Sliding Sleeve Cross Bolt Runner should rest against the slotted Sliding Sleeve, with a pre-compression force of approximately 60kg. If a space exists between the slot edge and the Cross Bolt Runner greater than 13mm, the Spring should be replaced.			
6.	Sliding Sleeve and Alignment Cross Bolt Inspect the alignment cross bolt, check for any deformation of the bolt. Check that the nylon bushings are in good condition (anti-rotation roll pin on older models) – Note: This is a special high yield strength bolt.			
7.	Landing Feet - Examine the feet to ensure that they are in good condition after the load test. The feet will normally recover full height sometime after the load test weight is relived.			
8.	Seat Base Assembly - Visually inspect for any wear or damage and ensure that all bolts' and other fasteners are fully secure.			
9.	Frame and Buoyancy - Visually inspect for any damage and ensure that all bolts and fasteners are tight and fully secure.			
10.	Inspection Data Plate - Check the date of the last examination/inspection has been correctly inserted and is indelibly legible.			

Reports		Complete Y/N	
11.	Photographic Report - Take the standard set of photos as detailed in the recommended inspection report template, including the ready for dispatch after completion of the post load test inspection.		
12.	Documentation / Report - Complete a report as recommended in the RML inspection template. Reflex Marine Ltd offer to keep an archive copy of your inspection records against the unit number. You can submit your completed checklists and photographs on www.reflexmarine.com/support .		
NOTES:			

6.8 Proof Load Testing

(NOTE: RML website www.reflexmarine.com/support should be checked for the latest version of the tables in this section)

Question	Response
When must a Proof Load Test be conducted?	<p>Immediately after any of the following events:</p> <ul style="list-style-type: none"> i. After replacement of any critical parts, does not apply to replacement of sling sets. ii. After any suspected damage arising from overloading or impact. iii. If the history of the FROG unit is uncertain. iv. If the inspection data plate is missing, illegible or out of date.
Who must conduct this test?	<p>The Load Test must be carried out by an independent test house company with nationally recognised accreditation in accordance with ILO 152. A competent and certified test person.</p>
Does this test require a formal record?	Yes.
What drawings are required to support this test?	The required drawings are available in Appendix B .
What equipment is required to perform this test?	<ul style="list-style-type: none"> i. Loading weights or sand bags (1145 kg). ii. Certified weighing scale or load cell. iii. Lifting equipment certified for > 5 Tonnes SWL. iv. A ladder or top access platform. v. An inspection frame or floor matting. vi. Good lighting. <p>A suitable means of safely accessing the top and the bottom parts of the FROG-3 is required. When using a step ladder or ladder it must be securely fixed to prevent slippage whilst accessing the top of the FROG. The FROG-3 can be laid on its side on protective matting, or the use of a secure inspection frame assembly to safely access the underside of the FROG- 3 is recommended. Do not go underneath an active lift. Be aware that in some regions “Working at Height” regulations may apply.</p>

6.8.1 Load Test Procedure

Table 4 details the required proof load tests that are applicable to the FROG-3. Following the load tests, a post load test visual inspection should be conducted as recommended in [Section 6.7](#).

Table 4: Proof Load Tests – FROG-3

Load Test Number	1	2
Components Under Test	<ul style="list-style-type: none"> i. Main Lift Eye. ii. Central Column Load Bearing Assembly. iii. Seats and Floor Structure. 	<ul style="list-style-type: none"> i. Back-up Lift-Eye. ii. Central Column Load Bearing Assembly. iii. Seats and Floor Structure.
Test Proof Load	1145 kg (2523 lb.)	1145 kg (2523 lb.)
Test Proof Load Distribution	540 kg (1168 lb.) on the seats and spread equally between them. 605 kg (1333 lb.) placed on the floor and distributed evenly.	540 kg (1168 lb.) on the seats and spread equally between them. 605 kg (1333 lb.) placed on the floor and distributed evenly.
Basis of Test Proof Load	Twice Maximum Gross Weight , less Tare Weight* = 2 x 815 kg – 485 kg = 1145 kg	Twice Maximum Gross Weight , less Tare Weight* = 2 x 815 kg – 485 kg = 1145 kg
Crane Hook Load	1630 kg	1630 kg
Test Method	Lift the unit and hold static for 5 minutes.	Lift the unit and hold static for 5 minutes.

** Note: The Tare Weight of the FROG-3 is approximately 485 kg but may vary slightly. Each FROG-3 must be weighed prior to load test.*

6.8.2 Inspection Data Plate

An inspection data plate will be issued and attached by the test house, which should show:

- i. Tare Weight (kg).
- ii. Pay load / SWL (kg).
- iii. Maximum gross load (kg).
- iv. The load test date.
- v. Test load (kg).
- vi. The serial number of the FROG-3: FS-XXX (where XXX is unit I.D. No).
- vii. The model number of the FROG-3: FS-01 (320) / (340) / (370).

6.9 Sling Replacement and Management



6.9.1 Sling Set (Critical Part) Replacement

Replace the sling set according to the usage of the FROG (see Table 3 in [Section 6.3](#)). This may be as frequently as every 3 months for very high use. Irrespective of apparent condition the lifting sling set should be replaced at least every 12 months.

6.9.2 Sling Set Management

The wire rope sling set supplied for use with the FROG-3 capsule is a critical component. Good management of sling sets is essential for ensuring safe personnel transfers.

Do

- i. Clearly identify that a sling is still within the current inspection / examination period.
- ii. Inspect the sling set prior to use. Open the Velcro cover and visually check both legs of the sling set for any signs of mechanical damage or corrosion which may affect the integrity of the sling set.
- iii. Ensure that the sling set is thoroughly examined by a Competent Person at intervals as specified in Table 3.
- iv. Discard slings that have not passed inspection.
- v. Use only original equipment manufacturer (OEM) slings as replacement sling sets.
- vi. Replace slings according to usage and inspection results.
- vii. Remove the Velcro cover if a FROG unit or the sling set is to be removed from service for more than one month.
- viii. Store sling sets in dry conditions when not in use.

Do Not

- i. Do not use a sling set which has not been visually inspected prior to use.
- ii. Do not use a sling set which has not been thoroughly examined by a Competent Person within the time interval as stated in Table 3. Note: for high and very high use, this frequency is every 3 months.
- iii. Never use a sling set which has been in service for more than 12 months.
- iv. Do not leave a sling set in a position where it is vulnerable to mechanical damage or contamination or where it may come into contact with abrasive or corrosive materials.
- v. Do not use a sling set which has incurred mechanical damage - including damaged eyes or ferrules, kinks, crimps, 'birdcages' or broken strands.
- vi. Do not secure the high visibility cover along its length with cable ties or similar which will prevent opening of the cover for inspection of the sling set.
- vii. Do not allow the sling set to become immersed in water or to be stored where it may be subject to sea water spray or fresh water spray.
- viii. Do not use non- original equipment manufacturer OEM sling sets.

6.10 Spares Kits and Replacement Parts



Use only genuine parts (including sling sets) provided by Reflex Marine Ltd.

Reflex Marine Ltd can supply critical and non-critical replacement parts as individual items or as appropriate kits. Prior to ordering any replacement parts or part kits, establish the FROG-3 Serial Number which is stamped on the Inspection Data Plate. The Number is typically FS-XXX where XXX represents a three digit number.

Replace the critical parts (as identified in the Examination Checklist) according to the usage of the FROG (see Table 3 in [Section 6.3](#)). This may be as frequently as every time a Visual Inspection or Examination is conducted (this could be every 3 months) up to every 3 years for the units with the lowest usage. All other replacement parts kits and parts should be replaced according to the advice of the Competent Person conducting the Visual and Examination procedure.

Any parts required for a FROG-3 can be ordered through support@reflexmarine.com.

6.10.1 Spares Kits

The following kits are available for routine and non-routine maintenance. Ordering an appropriate kit is more economical than replacing individual parts.

CRITICAL PARTS KITS (including lifting assembly)		
Kit Name	Kit Number	Contents
Standard FROG 3 (320)	Refer to FROG-3 unit serial number for correct kit number F-CPK-01-320 (for unit serial numbers FS-001 - 016) F-CPK-02-320 (for unit serial numbers FS-017 - 212) F-CPK-03-320 (for unit serial numbers FS-213 onwards)	1 x Main Lift-Eye Plug 2 x M16 Main Lift-Eye Securing Bolts 4 x M16 Washers 2 x M16 Securing Nuts 2 x M3 Split Pins 2 x Tamperproof Seals 1 x Stainless Steel Thread Lubricant And 1 x 30 ft. (9 m) Sling Set Assembly 2 x Shackles 1 x Sling Cover (red) 1 x Anti Fouling Bracket 1 x Shackle Spacer 4 x Heavy Duty Cable Ties And either For Type 1 (older) Keel Assemblies 1 x M48 Coarse (or Fine) Thread Nut (subject to FROG-3 serial number) 1 x Roll Pin 2 x M10 X 60mm Hex Bolts 2 x M10 Nyloc Nuts 2 x M3 Split Pins Or For Type 2 (newer) Keel Assemblies 1 x M48 Fine Thread Keel Plate Boss 1 x M10 x 95 mm Hex Bolt 2 x M10 Plain Washers 1 x M10 Nyloc Nut 1 x M3 Split Pin 1 x Tamperproof seal
Arctic FROGs (340)	Refer to FROG-3 (340) unit serial number for correct kit number F-CPK-01-340 (for unit serial numbers FS-001 - 016) F-CPK-02-340 (for unit serial numbers FS-017 - 212) F-CPK-03-340 (for unit serial numbers FS-213 onwards)	1 x Main Lift-Eye Plug (M40 version) 2 x M16 Main Lift-Eye Securing Bolts 4 x M16 Washers 2 x M16 Securing Nuts 2 x M3 Split Pins 2 x Tamperproof Seals 1 x Stainless Steel Thread Lubricant And 1 x 30 ft (9 m) Sling Set Assembly (340 version) 2 x Shackles 1 x Sling Cover (yellow)

		<p>1 x Anti Fouling Bracket 1 x Shackle Spacer 4 x Heavy Duty Cable Ties</p> <p>And either</p> <p>For Type 1 (older) Keel Assemblies 1 x M48 Coarse (or Fine) Thread Nut (M40 version) (subject to FROG-3 serial number) 1 x Roll Pin 2 x M10 X 60 mm Hex Bolts 2 x M10 Nyloc Nuts 2 x M3 Split Pins</p> <p>Or</p> <p>For Type 2 (newer) Keel Assemblies 1 x M48 Fine Thread Keel Plate Boss (M40 version) 1 x M10 x 95 mm Hex Bolt 2 x M10 Plain Washers 1 x M10 Nyloc Nut 1 x M3 Split Pin 1 x Tamperproof seal</p>
--	--	--

REPLACEMENT PARTS KITS (NOT with lifting assembly)		
Kit Name	Kit Number	Contents
Standard FROG 3 (320)	Refer to FROG-3 unit serial number for correct kit number F-RPK-01-320 (for unit serial numbers FS-001 - 016) F-RPK-02-320 (for unit serial numbers FS-017 - 212) F-RPK-03-320 (for unit serial numbers FS-213 onwards)	1 x Main Lift-Eye Plug 2 x M16 Main Lift-Eye Securing Bolts 4 x M16 Washers 2 x M16 Securing Nuts 2 x M3 Split Pins 2 x Tamperproof Seals 1 x Stainless Steel Thread Lubricant And either For Type 1 (older) Keel Assemblies 1 x M48 Coarse (or Fine) Thread Nut (subject to FROG-3 serial number) 1 x Roll Pin 2 x M10 X 60mm Hex Bolts 2 x M10 Nyloc Nuts 2 x M3 Split Pins Or For Type 2 (newer) Keel Assemblies 1 x M48 Fine Thread Keel Plate Boss 1 x M10 x 95 mm Hex Bolt 2 x M10 Plain Washers 1 x M10 Nyloc Nut 1 x M3 Split Pin 1 x Tamper Proof Seal
Arctic FROG 3s (340)	Refer to FROG-3 unit serial number for correct kit number F-RPK-01-340 (for unit serial numbers FS-001 - 016) F-RPK-02-340 (for unit serial numbers FS-017 - 212) F-RPK-03-340 (for unit serial numbers FS-213 onwards)	1 x Main Lift-Eye Plug (M40 version) 2 x M16 Main Lift-Eye Securing Bolts 4 x M16 Washers 2 x M16 Securing Nuts 2 x M3 Split Pins 2 x Tamperproof Seals 1 x Stainless Steel Thread Lubricant And either For Type 1 (older) Keel Assemblies 1 x M48 Coarse (or Fine) Thread Nut (M40 version) (subject to FROG-3 serial number) 1 x Roll Pin 2 x M10 X 60 mm Hex Bolts 2 x M10 Nyloc Nuts 2 x M3 Split Pins Or For Type 2 (newer) Keel Assemblies 1 x M48 Fine Thread Keel Plate Boss (M40 version) 1 x M10 x 95 mm Hex Bolt 2 x M10 Plain Washers 1 x M10 Nyloc Nut 1 x M3 Split Pin 1 x Tamperproof Seal

LIFTING SLING ASSEMBLY PARTS KITS		
Kit Name	Kit Number	Contents
Standard FROG 3 (320) – 30ft Lifting Assembly Kit	220-30-A	1 x 30 ft (9 m) Sling Set Assembly c/w 2 x Shackles 1 x Sling Cover (red) 1 x Anti Fouling Bracket 1 x Shackle Spacer 4 x Heavy Duty Cable Ties
Arctic Frog 3 (340) - 30 ft. Sling Set Kit	240-30-A	1 x 30 ft (9 m) Sling Set Assembly c/w 2 x Shackles 1 x Sling Cover (yellow) 1 x Anti Fouling Bracket 1 x Shackle Spacer 4 x Heavy Duty Cable Ties

OTHER SERVICE KITS		
Kit Name	Kit Number	Contents
Back-Up Lift-Eye Refurbishment Kit	F-BEK-01 (all unit serial numbers)	1 x Back-Up Lift-Eye 1 x M24 Nut 1 x 3 mm x 50 mm Split Pin 1 x Tamper Proof Seal
Landing Feet Kit (320 & 340) Standard and Arctic	F-LFK-320 (all unit serial numbers)	3 x Feet (foam) 3 x M20 x 200 mm Hex bolts 3 x M20 Hex Nyloc Nut 6 x M20 Plain Washer 3 x Nylon Cone Washer
Landing Feet Kit (370) Tropical	F-LFK-370 (all unit serial numbers)	3 x Feet (foam) 3 x M20 x 200 mm Hex bolts 3 x M20 Hex Nyloc Nut 6 x M20 Plain Washer 3 x Nylon Cone Washer
Restraint Harness Kit	F-RHK-02 units nos 0-212 F-RHK-03 units nos 213 onwards	3 x Seat Harnesses Plus Fixings
Full Service Kit	For new frogs (unit no's 213 onwards) F-FSK-03-320 F-FSK-03-340 F-FSK-03-370	This kit combines the following Kits: i. Critical Parts Kit ii. Back-Up Lift-Eye Kit iii. Landing Feet Kit

6.10.2 All Other Replacement Parts

Reflex Marine Ltd carries spares and accessories stock and is able to supply most individual components of the FROG-3 (see [Appendix C](#)).

In many cases an Operator is advised to carry a local spare parts stock inventory to ensure the continued safe operation of the FROG unit. Minimum stock quantities shall be influenced by:

- i. Remoteness of location and certifying authority.
- ii. Criticality of maintaining crew and emergency response (MedEvac) access.
- iii. Usage envelope.
- iv. Customs processing time.
- v. Cost of logistics for small parts.

Reflex Marine Ltd would be pleased to offer the recommended minimum stock items for critical and replacement parts for your operation, please contact support@reflexmarine.com.

6.11 Unit Replacement Recommendation

The FROG design is strong and robust and is able to be refurbished to full working capacity. FROGs work in a very wide range of operating conditions and environments. The work they perform and the way they are maintained and looked after has wide variability.

Reflex Marine Ltd expects all FROGs to provide many years of excellent reliable service with minimal operating costs.

RML do however recommend that after a certain duty cycle, it is time to renew this critical lifting equipment. Based on RML's field observations and usage category, RML has established the recommended unit retirement age as specified in Table 3 in [Section 6.3](#).

RML would be pleased to offer renewal customers attractive quotes for the latest equipment.

7 UNIT IDENTIFICATION

7.1 Product ID Numbers

There are currently three versions of the FROG-3. The model numbers are:

- FS-01 (320) Standard: Standard 3 passenger version with the facility to carry a stretcher.
- FS-01 (340) Arctic: A low temperature version of FS-01, certified for use down to -40 deg C.
- FS-01 (370) Tropical: Fitted with Tropical Feet formulae designed for higher longevity in high heat and humidity conditions

7.2 Part Numbers

In the drawing / part numbering system, each assembly or part is assigned a three part number which provides the unique identification of the part /assembly.

7.3 FROG-3 Serial Numbers

Every FROG-3 built is assigned a build serial number. These serial numbers are allocated sequentially in the order in which FROG-3 units are built. Serial numbers start from FS-001, and continue in numerical sequence. The serial number for each FROG-3 will be stamped on a plate, which is attached to each unit.

7.4 Component Serial Numbers

Where material grades and material traceability are deemed to be safety critical these components will be allocated unique component numbers which will be stamped or etched as required. Components that require unique identification are referenced in the Parts List.

For bolts, where etching is impractical, batches of bolts will be colour coded and a note added to the mill certificate to identify the colour coded bolts with a particular mill certificate.

8 HANDLING, SHIPPING AND STORAGE

8.1 Dimensions

The FROG-3 overall dimensions are as follows:

In standard 3 seat mode:

Height	2900 mm	(9.5 ft)
Max Width 1	2200 mm	(7.2 ft)
Max Width 2	2500 mm	(8.2 ft)
Tare Weight	485 kg	(1069 lb)

In stretcher mode:

Height	2900 mm	(9.5 ft)
Max Width 1	2400 mm	(7.9 ft)
Max Width 2	3200 mm	(10.5 ft)
Tare Weight	485 kg	(1069 lb)

8.2 Handling & Transportation

8.2.1 Forklift

Handling of the FROG-3 with a forklift truck may damage the underside of the FROG-3 (landing feet, cross braces or main column). Therefore the unit must be secured to a pallet specifically designed for forks.

8.2.2 Crane

When lifting the FROG-3 with short chain or strop, a temporary shackle should be fixed to the back-up eyebolt. Care must be taken not to damage the FROG-3 lifting sling set. **The shackle should not be fitted through the thimble of the sling eye.**

8.2.3 Securing

For deck fastening, Reflex Marine Ltd recommends using the peripheral braces around the floor grating. An example showing a deck fastening configuration is shown in Figure 11.

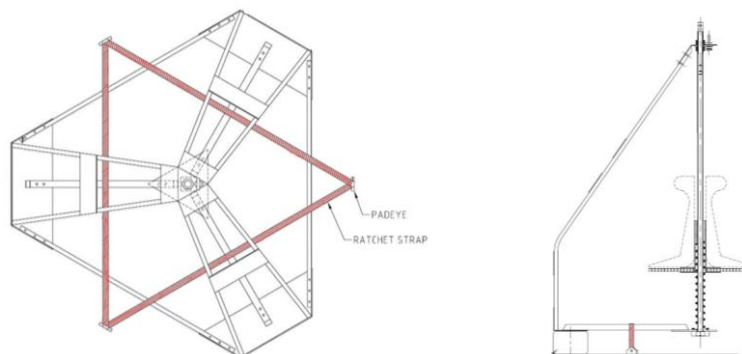

Figure 11: FROG-3 Recommended Strapping Method

8.2.4 Inspection

Before and after transportation the FROG-3 must be inspected to check for damage sustained in transit. The unit must not be used if any structural damage is observed. If any damage has been observed please refer to section 6.3, item iv for remedial instructions.

8.2.5 Preparation for Road Transport

The FROG-3 should be shipped in seated mode. Prior to shipping, the seat harnesses must be secured by tightening the seat harnesses and tying the buckles together. This will prevent seat harnesses flapping and damaging the seating area. It is recommended that the FROG-3 is covered for shipping either with a FROG-3 weatherproof protective cover or other heavy duty tarpaulin material.

8.2.6 Containerisation

The FROG-3 will not fit in a standard or high-cube container. If the FROG-3 is transported on flat rack it must be secured. Recommended securing points are the radial / peripheral floor braces. To protect it from excess loading, the main lifting eye must not be used as securing point. Feet must be supported to prevent collapse by placing suitable chocks or props under the unit.

Shipping-crating Frog-3

Type	Length	Width	Height	Mass
Unpacked	2.5 m	2.2 m	2.9 m	c. 485 kg
Pallet/Skid – Frog Unit Upright	2.5 m	2.2 m	3.0 m	c. 550 kg
Pallet/ Skid – Frog Unit on Side	3.1 m	2.6 m	2.6 m	c. 600 kg
Full Crating – Frog Unit Upright	2.8 m	2.4 m	3.2 m	c.1050 kg
Full Crating – Frog Unit on Side	3.1m	2.8m	2.5m	C 1050 kg
Slatted Crating – Frog Unit Upright	2.8 m	2.4 m	3.2 m	c. 900 kg

8.2.7 Storage

The FROG-3 has been designed to cope with the harsh conditions on an offshore installation or vessel; however it is important to protect the unit as much as possible from any hazardous elements and UV degradation.

It is recommended that the FROG-3 is covered with the FROG-3 weatherproof cover whilst not in use. The cover fits the standard FROG-3 in both configurations.

A heavy duty version of the protective cover is also available (awaiting photo)

Fig 12: FROG-3 Protective Cover



8.2.8 Feet Deformation During Storage

Prolonged periods of exposure to hot decks and self-weight can cause permanent set deformation of the elastomeric feet. It is advised that if the Frog is to be stored for prolonged periods of inactivity then the user should consider a set of chocks to lift the feet away from the deck.

Reflex can supply a dedicated set of supporting chocks that are designed to fit properly underneath the main base frame of the Frog 3 without impinging any exposed bolt heads. The chocks are pre-laid on the deck ready for landing the Frog directly to the storage position.



9 APPENDIX A – TRANSFER LOG

MARINE PERSONNEL TRANSFER LOG			
Date		From (vessel name)	
Transfer Time		To (vessel name)	
Unit Type		Crane (port / starboard etc)	
Wind Speed		Sea State	
Wind Direction		Visibility	
Transfer Classification	ROUTINE / EMERGENCY		
Reason for Transfer			
Other Factors Affecting Transfer (vessel position / deck space etc)			

Passenger Details			
Passengers are requested to sign below if they consent to undertaking the transfer detailed above. <i>Important note to passengers – Certain National regulations place constraints on the use of personnel transfers. Passengers should ensure they are aware of any local regulations prior to proceeding.</i>			
Name	Designation	Signed consent	Time / Date

TO BE COMPLETED BY THE LIFT SUPERVISOR			
Have operating instructions in the capsule been read and understood?			YES / NO
Has the condition of the transfer capsule and associated equipment been checked?			YES / NO
Have passengers been fully briefed on the operation?			YES / NO
Hazards Identified			YES / NO
Action Taken to Minimise Hazards			
The transfer was carried out without incident			YES / NO
Name	Position	Signature	Time / Date
ADDITIONAL COMMENTS			

10 APPENDIX B – DRAWINGS

Drawing No	Revision	Description
320 (Sheet 1 & 2)	B	FROG 3 General Assembly
320-01 (Sheet 4)	B	FROG 3 General Assembly (Medivac Configuration)
320-03 (Sheet 1)	B	FROG 3 Central Column Assembly
220-30	A	30ft Lifting Assembly
No reference		Sliding Sleeve and Cross Bolt Diagram

ITEM NO.	PART NUMBER	DESCRIPTION	Default/QTY.	Previous Part No.	STANDARD OR AUXILIARY		REVISIONS				
1	320-01-B	FROG-3 ASSEMBLY	1	-		⚠	ECHO.	REV	DESCRIPTION	DATE	APPD
2	220-30-A	30FT LIFTING ASSY (-20 TO +50 DEG C)	1	N/A	STD	⚠		A	FIRST ISSUE	13-01-11	DB
3	220-20-A	20FT LIFTING ASSY (-20 TO +50 DEG C)	1	N/A	AUX	⚠		B	ITEM 1 RAISED IN ISSUE. PREVIOUS PT No 2 REMOVED FROM ITEMS 2-5. SMT2 OR S-C BALLOON 4 MOVED TO COLUMN A	10/05/2011	DB
4	220-15-A	15FT LIFTING ASSY (-20 TO +50 DEG C)	1	N/A	AUX	⚠					
5	220-10-A	10FT LIFTING ASSY (-20 TO +50 DEG C)	1	N/A	AUX	⚠					

2192

2515

2691

1

2

DETAIL A (1:5)

DRAWN	R J PUDD 13-01-11	MATERIAL SPECIFICATION SEE DETAILS	WEIGHT 485 Kg	3rd ANGLE PROJECTION	REFLEX MARINE LTD
CHECKED	RP 13-01-11	FINISH SEE DETAILS	SCALE 1:25 NO. OFF ONE	ALL DIMENSIONS IN mm UNLESS OTHERWISE STATED	SOMAR HOUSE, HERON WAY, TRURO, CORNWALL, UK WWW.REFLEXMARINE.COM
APPROVED	DB 13-01-11	SURFACE TREATMENT REFER TO BUILD MANUAL	TOLERANCES UNLESS SPECIFIED 0 DEC PLACE +/- 1 1 DEC PLACE +/- 0.25 2 DEC PLACE +/- 0.1 ANGULAR +/- 1.4°	ALL DIAPHERS CONCENTRIC 0.35 TYP SURFACE FINISH ALL DIMENSIONS	TITLE FROG-3 GENERAL ASSEMBLY
THIS DRAWING, DESIGN AND SPECIFICATION ARE THE PROPERTY OF REFLEX MARINE LTD AND MAY NOT BE REPRODUCED OR USED IN WHOLE OR PART AS THE BASIS FOR SALE					DRAWING NO. 320-B
©2011 REFLEX MARINE LTD OF SOMAR HOUSE, HERON WAY, TRURO, CORNWALL, TR1 3JN					SHEET 1 OF 2

ITEM NO.	PART NUMBER	DESCRIPTION	ACCESSORIES/QTY.	Previous Part No.	STD OR AUX
1	300-01-01-A	FROG-3 BASKET STRETCHER	1	F-01-120	AUX
2	300-02-A	STROBE LIGHT TYPE AQ-4	1	F-01-122	AUX
3	300-03-A	STROBE LIGHT - LT131	1	F-01-250	AUX
4	300-04-A	RIGID LUGGAGE BOX ASSY	1	F-ASY-14-B	AUX
5	300-05-A	FROG-3 TROLLEY	1	F-01-150-B	AUX
6	300-06-A	FROG-3 COVER	1	F-01-151	AUX



ITEM 2
STROBE LIGHT FOR
NON-ZONED
APPLICATIONS



ITEM 3
STROBE LIGHT FOR
ZONED
APPLICATIONS

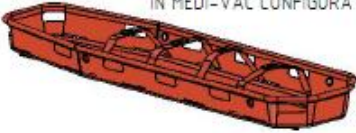

ITEM 1
BASKET STRETCHER FOR USE
IN MEDI-VAC CONFIGURATION



ITEM 6
FROG-3 COVER

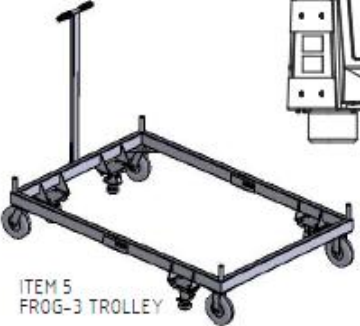

ITEM 5
FROG-3 TROLLEY

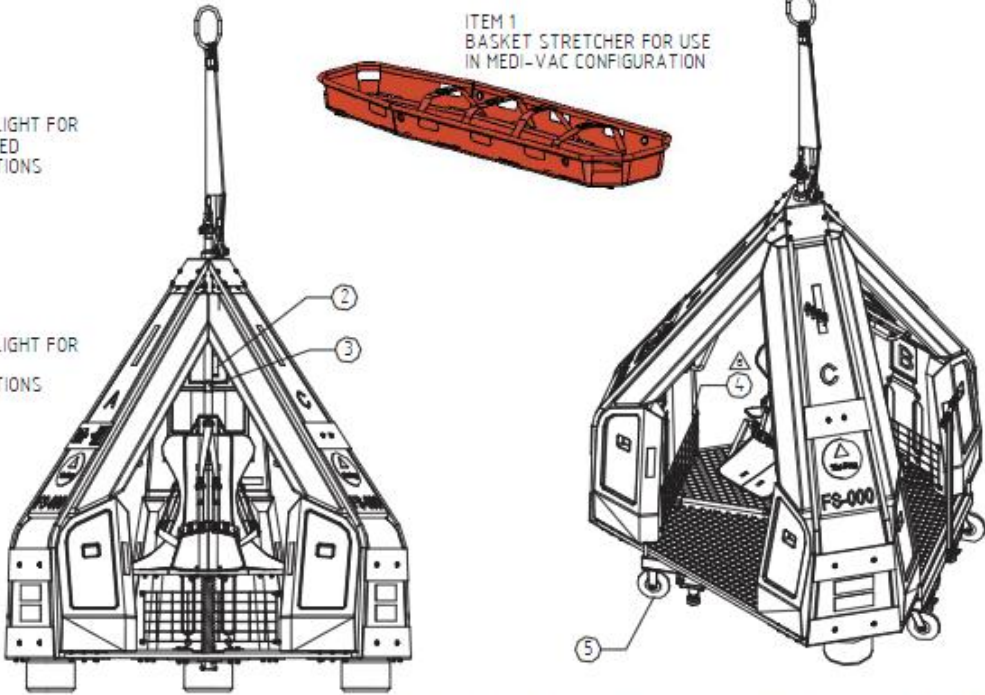



ITEM 4
RIGID LUGGAGE BOX
LOCATED INSIDE
COLUMN 'A' ONLY

DRAWN	RJ PUJOSÉ 13-01-11	MATERIAL SPECIFICATION SEE DETAILS	WEIGHT: 485 Kg	3rd ANGLE PROJECTION	REFLEX MARINE LTD SOMAR HOUSE, HERON WAY, TRURO, CORNWALL, UK WWW.REFLEXMARINE.COM
	CHECKED	RP 13-01-11	FINISH SEE DETAILS	SCALE 1:25 NO. OFF ONE	
APPROVED	DB 13-01-11	SURFACE TREATMENT REFER TO BUILD MANUAL	<small> TOLERANCES UNLESS OTHERWISE SPECIFIED: Ø DEC. PLACE +/- 0.1 1 DEC. PLACE +/- 0.05 2 DEC. PLACE +/- 0.1 ANGULAR +/- 1/4° DRAWING PREPARED IN ACCORDANCE WITH BS8888-2008 THIS DRAWING, DESIGN AND SPECIFICATION ARE THE PROPERTY OF REFLEX MARINE LTD AND MAY NOT BE REPRODUCED OR USED IN WHOLE OR PART AS THE BASIS FOR SALE. © 2013 REFLEX MARINE LTD OF SOMAR HOUSE, HERON WAY, TRURO, CORNWALL TR1 2JH </small>		TITLE FROG-3 GENERAL ASSEMBLY DRAWING NO. 320-B
					SHEET 2 OF 2

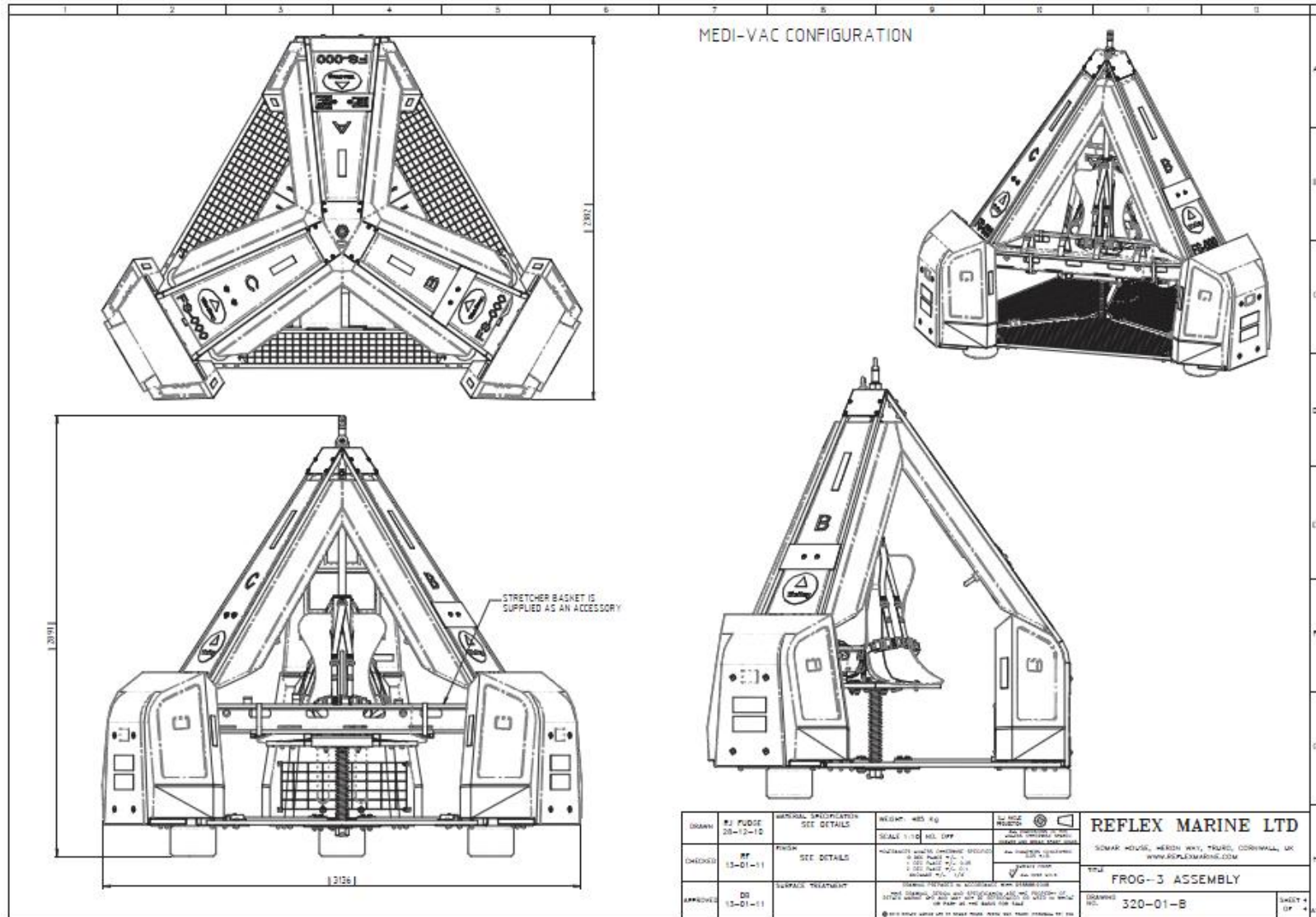

ITEM NO.	PART NUMBER	DESCRIPTION	CHAL QUANTITY	MED VAC COMP QTY
1	320-02-01-A	FROG-3 KEEL PLATE	1	1
2	320-02-01-A	FROG-3 CAP PLATE	1	1
3	320-02-03-A	FROG-3 BACK UP PAD EYE PLATE	1	1
4	320-02-04-B	FROG-3 BACK UP EYE BOLT	1	1
5	320-02-05-A	FROG-3 SEAT FRAME	1	1
6	320-02-06-B	FROG-3 CENTRAL SPRING	1	1
7	320-02-07-A	NUT, HEX M4.8 x 3.0 FINE THREAD	2	2
8	320-02-08-A	FROG-3 UPPER CENTRALISER	1	1
9	320-02-09-A	FROG-3 INNER CENTRALISER	1	1
10	320-02-10-B	FROG-3 BEARING RUNNER	2	2
11	320-02-11-A	FROG-3 ORIENTATION PLATE KEEL NUT	1	1
12	320-02-12-A	FROG-3 SEAT	3	2
13	320-02-13-A	FROG SEAT HARNESS - RED	3	3
14	320-02-14-A	SPACER, SEAT HARNESS	3	3
15	320-02-15-B	FROG-3 SLIDING SLEEVE BOLT	1	1
16	320-02-16-A	M10-60 BOLT WITH CROSS HOLE	1	1
17	320-04-B	FROG-3 LOAD PATH ASSEMBLY	1	1
18	320-06-B	FROG-3 SLIDING SLEEVE WELDMENT	1	1
19	320-06-02-B	FROG-3 CIRCULAR SEAT SUPPORT	1	1
20	100-000-7E-L	TAMPER PROOF SEAL	1	1
21	103-030-SP-L	SPLIT COTTER PIN Ø3.30 DIN 93 AL	2	2
22	103-050-SP-L	SPLIT COTTER PIN Ø3.50 DIN 93 AL	1	1
23	110-050-SB-L	M10-60 SOC BUT HD SCREW ISO7380 AL	3	2
24	110-060-HB-L	M10-60 HEX HD BOLT B53492 AL	3	3
25	110-060-SB-L	M10-60 SOC BUTTON HD ISO7380 AL	6	4
26	110-000-NN-L	M10 HEX NYLOC NUT B54929 AL	18	18
27	110-000-WA-L	M10 FLAT WASHER FORM A B54300 AL	6	6
28	110-035-SB-L	M10-35 SOC BUT HD SCREW ISO7380 AL	3	3
29	110-030-WP-L	M10-30 PENNY WASHER AL	3	2
30	112-000-NN-L	M12 HEX NYLOC NUT B54929 AL	1	1
31	112-030-WP-L	M12-30 PENNY WASHER	2	2
32	116-000-HB-L	M16-60 HEX HD BOLT B53492 AL	3	3
33	116-000-NN-L	M16 HEX NYLOC NUT B54929 AL	3	3
34	116-000-WA-L	M16 FLAT WASHER FORM A B54300 AL	3	3
35	124-000-NP-L	M24 HEX FULL NUT B53492 AL	1	1
36	320-02-17-B	FROG-3 STRETCHER FRAME	-	1
37	320-02-18-A	STRETCHER SECURING STRAPS	-	2
38	110-050-SB-L	M10-60 SOC BUT HD SCREW ISO7380 AL	-	1
39	110-000-NW-L	NUT, WING M10 AL	-	1
40	300-01-01-A	FROG-3 BAGNET STRETCHER	-	1

VIEW OF UNDERSIDE KEEL PLATE REMOVED FOR CLARITY

SEE DETAIL F TYP 3 PLACES

SEE DETAIL D

SEE DETAIL I

DETAIL O (1) (2) SHOWING SPLIT PIN AND TAMPERPROOF SEAL SEE SHT 2, 1-A, FOR EYEBOLT ORIENTATION

DETAIL D (1) (2) SHOWING SEAT BELT TOP FIXING TYP 3 PLACES

DETAIL E (1) (2) SHOWING SEAT TOP FIXINGS, TYP 3 PLACES

DETAIL C (1) (2) SHOWING SEAT FRONT FIXINGS, TYP 3 PLACES

DETAIL I (1) (2) SHOWING SECURING SEAT FRAME, TYP 3 PLACES

DETAIL F (1) (2) SHOWING SEAT BELT FIXING, TYP 3 PLACES

NOTE
SHEET 1 & 2 - 3 SEAT CONFIGURATION
SHEET 3 - MEDI-VAC CONFIGURATION

DATE	REV	DESCRIPTION	DATE	APPRO
	A	FIRST ISSUE	12-01-11	DB
	B	SMALLER EYELET FRAME CORRECTED TO BS WASHER ORIENTED AND ITEM 28 CHANGED TO FULL NUT FOR T-ALL CORRECTIONS TO TENS C & D B 17 & 18 25 355, SHT 2 DR. 12-01-11	10/08/2011	DB

DRAWN: RJ PUDC 20-12-10 CHECKED: BY 13-01-11 APPROVED: DB 13-01-11	MATERIAL SPECIFICATION SEE DETAILS FINISH SEE DETAILS SURFACE TREATMENT	WEIGHT: 125.88 Kg SCALE: 1:10 NO. OF PARTS: ONE MANUFACTURE AND/OR FINISHING SPECIFICATIONS:	REFLEX MARINE LTD SOMAR HOUSE, HERON WAY, TRURO, CORNWALL, UK WWW.REFLEXMARINE.COM TYPE: FROG-3 CENTRAL COLUMN ASSEMBLY DRAWING NO: 320-03-B
--	---	---	--

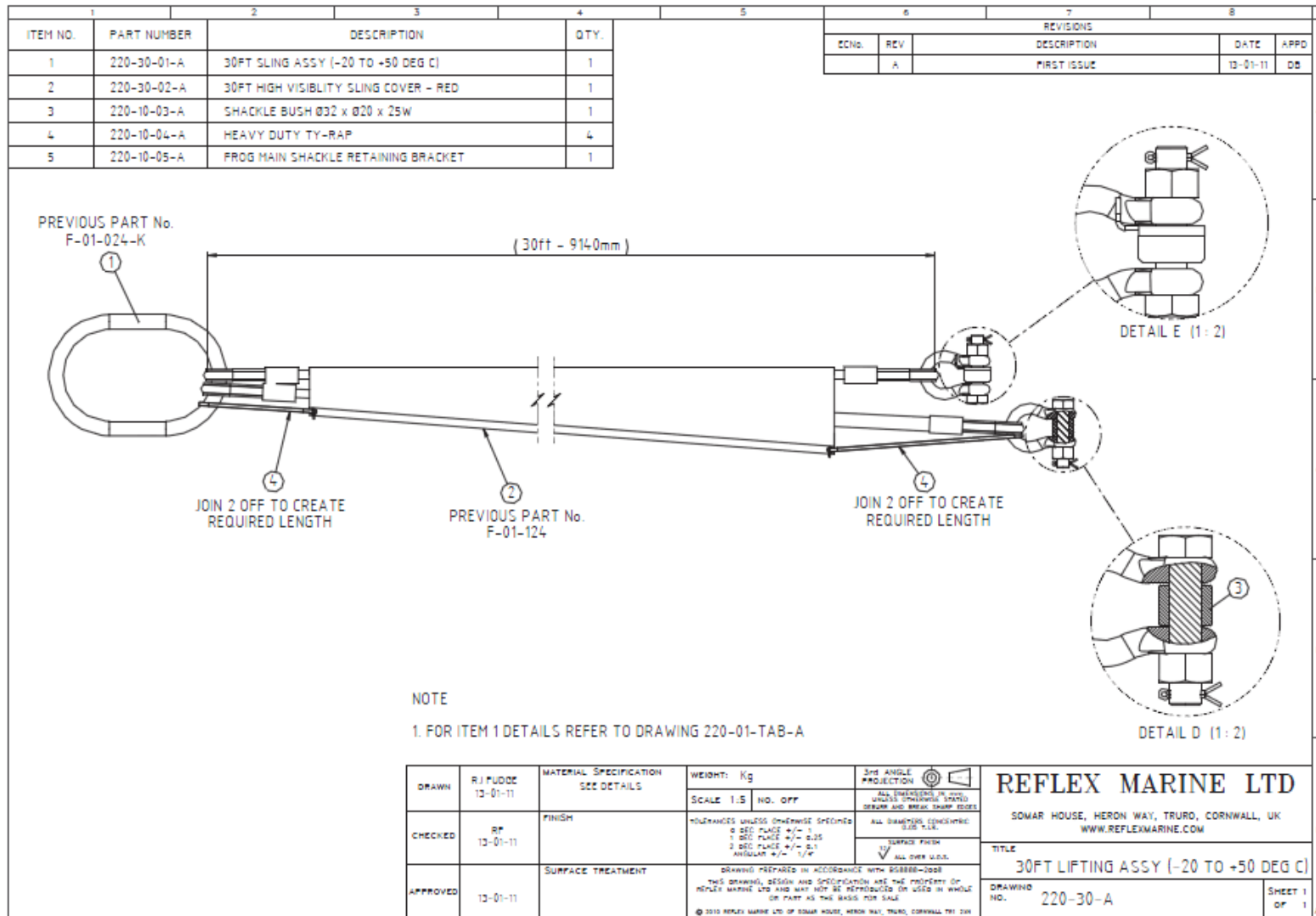

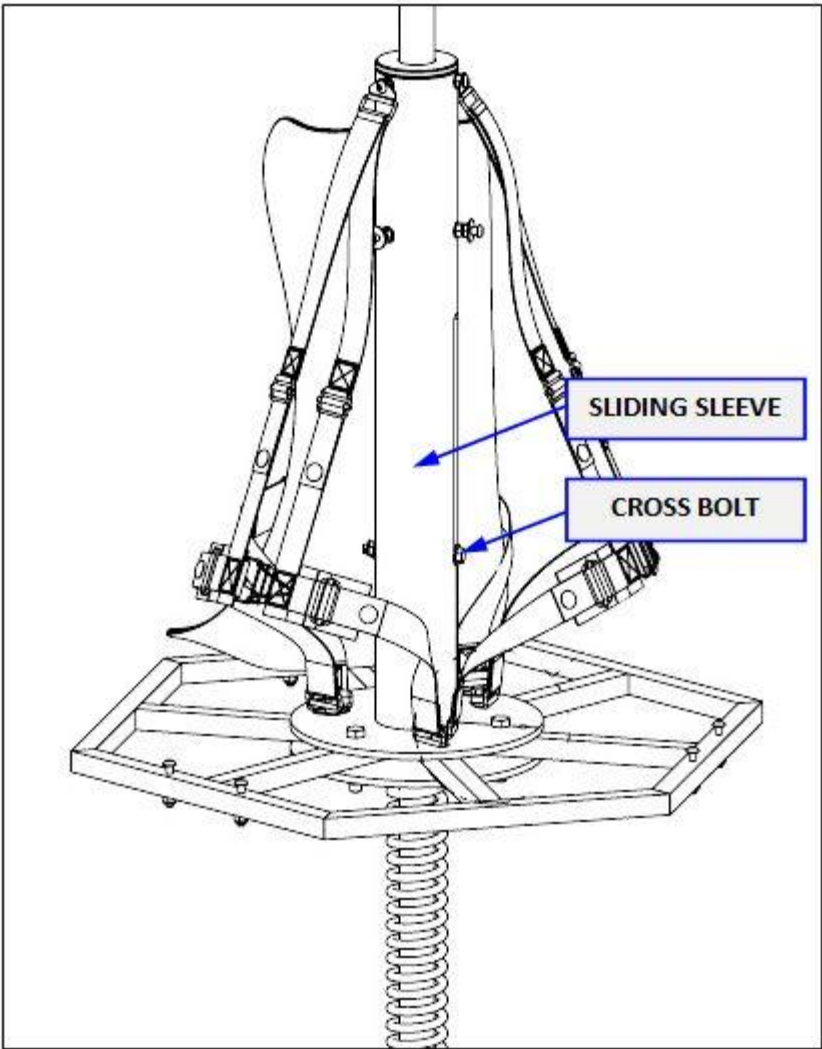

11 APPENDIX C – PARTS AND MATERIAL SPECIFICATIONS

11.1 Parts

Due to the numerous revisions to the Frog 3 build over time and the variations between standard, Arctic and Tropic version, we have decided to omit the most current parts listing from this User Manual as it was a source of confusion for customers with older versions of Frog 3. Shortly Reflex Marine will be offering a parts and kits lookup facility on the website where the customer can get a direct listing of parts specific to each frog built. We believe this facility will aid the customer find the correct parts. In the absence of having this facility up and running, please contact us directly on support@reflexmarine.com if you require any assistance with identifying the correct replacement parts for your FROG-3.

11.2 Definition According to Criticality

Critical components are those in which, if failure were to occur, there would be a high risk to the safety of the passengers in the FROG-3. The critical components are all connected to the Main Support Tube, which is the prime structural component in the design.

11.3 Fastener Specifications

Because of corrosion considerations, all fasteners on the FROG-3 are supplied in stainless steel suitable for marine use. All nuts and bolts must be Grade A4 or A2. All nuts should be fitted with NYLOC inserts where applicable.

11.4 Certification

Certification Supplied is identified with the following letters:

MC - Material Certificate

CC - Certificate of Conformance

LTC - Load test Certificate

NDE - Non-Destructive Examination Report

12 APPENDIX D – FROG-3 MARKINGS

12.1 Essential Marking Requirements

The FROG-3 should be indelibly marked with the following information:

- i. CE Mark.
- ii. Description of Equipment.
- iii. Model.
- iv. Serial Number.
- v. Manufacturer’s Address.
- vi. Year of Construction.
- vii. Mass of Usual Configuration / Mass without Payload (Tare weight).
- viii. Safe Working Load (SWL).
- ix. Maximum Gross Mass (MGM).
- x. Maximum Number of Passengers.

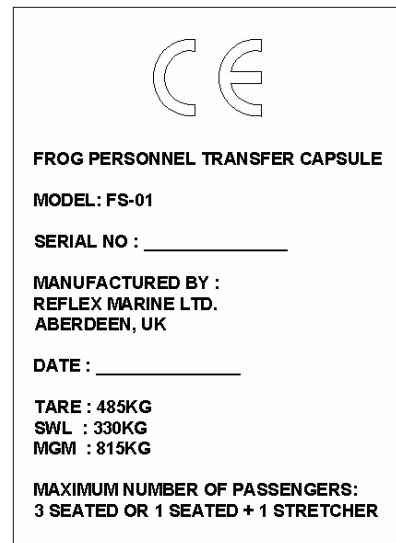

Fig 13: FROG-3 CE Marking Plate



12.2 Decal - Vinyl Stickers - Located on Outside of Buoyancy Units

Note: MDPE Buoyancy requires preparation of surface for good contact adhesion. Gently heat the contact area until the surface is oxidised and appears shiny.

Refer to diagram FROG-3 Column Marking Plan for layout:

- i. 3 off Circular FROG Logo - 250 dia.
- ii. 3 off Rectangle Reflex Marine Ltd Logo – 250 x 125.
- iii. 2 off Rectangle Reflex Marine Ltd URL “www.reflexmarine.com” - 250 x 100.
- iv. 1 off Rectangle Reflex Marine Ltd Tel No “+44 (0)1872 321155” - 250 x 100.
- v. Buoyancy columns numbered "A, B, C" Arial bold 150 mm height, black on upper buoyancy.
- vi. 9 off per Reflective tape (2 x 110 mm on lower and 1 x 220 mm on upper buoyancy).

12.3 Decal - Vinyl Stickers - Located Inside of Lower Buoyancy Units

Note: MDPE buoyancy requires preparation of surface for good contact adhesion. Gently heat the contact area until the surface is oxidised and appears shiny.

Refer to diagram FROG-3 Column Marking Plan for layout:

- i. Buoyancy columns numbered "A, B, C" Arial bold 150 mm height, black (See F-ASY-01) - Stretcher seat column marked "A" and "B" and "C" clockwise.
- ii. Notice "FIX LOWER BUOYANCY UNIT **B & C** TO OUTSIDE OF FRAME FOR STRETCHER TRANSFERS. (FITTINGS PLACED FROM OUTSIDE)".
- iii. “NO HAND HOLD” sticker at upper/ lower buoyancy interface. One at each end of lower buoyancy block.
- iv. For unit numbers FS-001 to FS-016 the buoyancy fixings for columns B and C should be marked with a permanent marker, "TOP B" and "BOTTOM B". This is to avoid confusion with adjustments for stretcher mode.

12.4 Decal - Operating Instructions - Located Inside of Upper Buoyancy Units

Note: MDPE buoyancy requires preparation of surface for good contact adhesion. Gently heat the contact area until the surface is oxidised and appears shiny.

Refer to diagram FROG-3 Column Marking Plan for layout:

- i. Operating Instructions.
- ii. Seat Change out Plan.
- iii. Stretcher Change Out.
- iv. 2 off SWL Rating Notice "THIS UNIT IS SUITABLE FOR 3 MEN SEATED OR 1 MAN SEATED PLUS 1 STRETCHER PASSENGER TRANSFERS ONLY. 20 KG LUGGAGE PER PERSON. SWL = 330 KG".
- v. 3 off Safety Notice “KEEP FEET INSIDE FROG”.

Positioned as follows:

	Column A	Column B	Column C
Operating Instructions	2 x A4 page	-	-
Seat Change Out Plan			1
Stretcher Fitting Guide		1	
SWL Rating		1	1
Safety Notice – “Keep Feet Inside Frog”	1	1	1

12.5 Decal - Operating Instructions - Located on Seat Back

3 off sticker "ENSURE THAT BELTS ARE PROPERLY ADJUSTED AND TIGHTENED BEFORE LIFT-OFF"

Or

3 off sticker “LOOSEN BELT, TIGHTEN WAIST STRAPS FIRST, THEN SHOULDER STRAPS”

12.6 FROG-3 Column Marking Plan

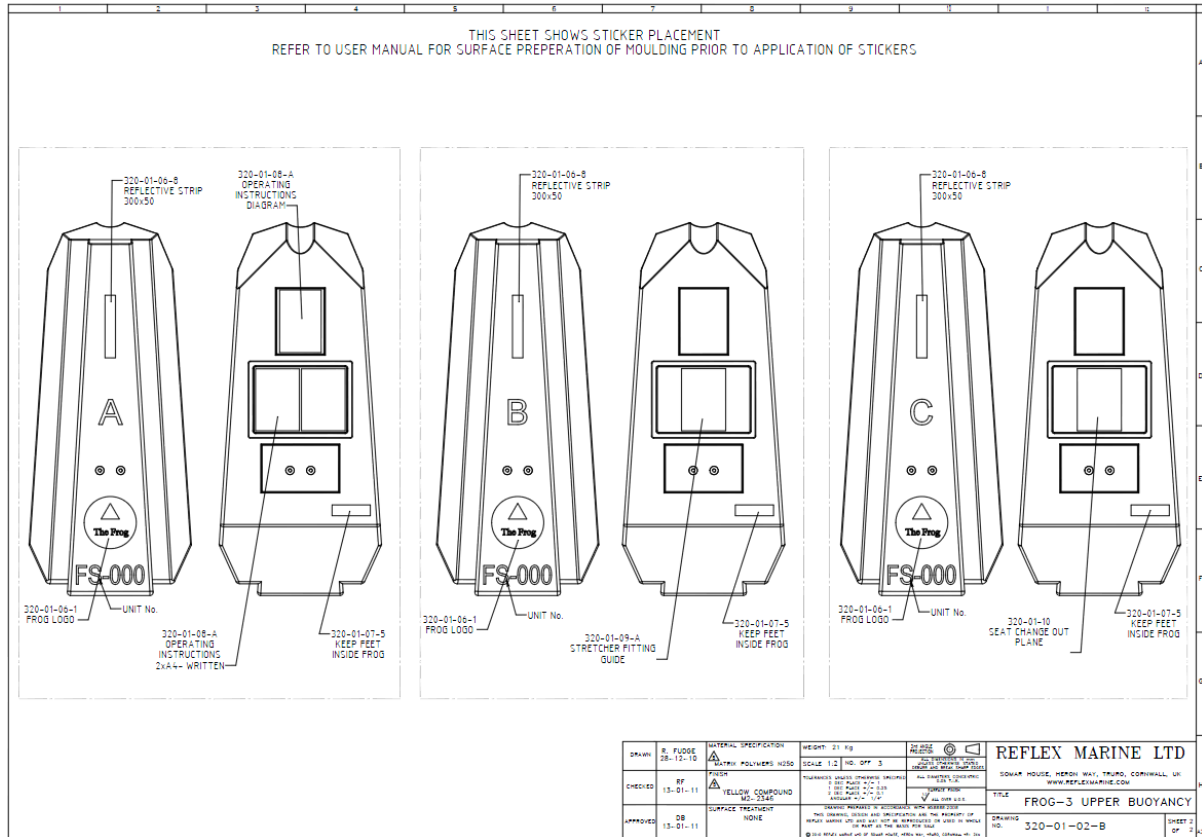
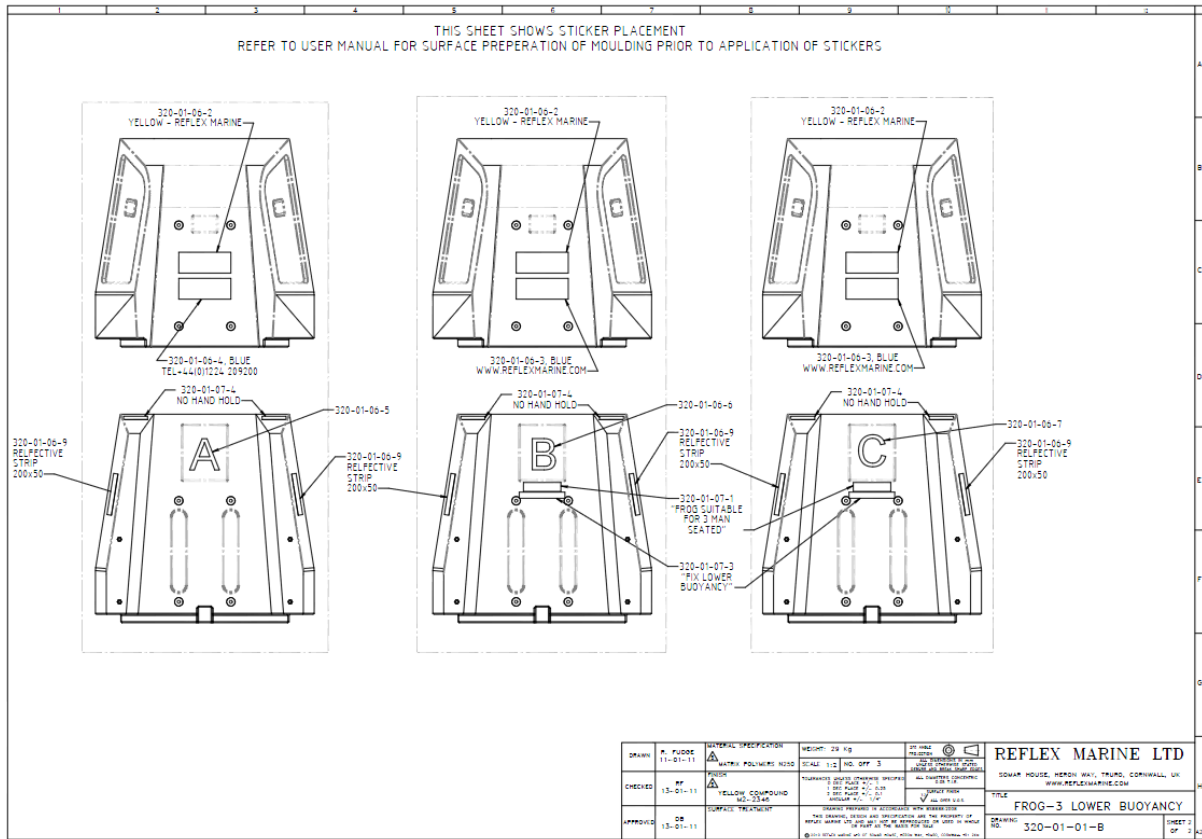

13 APPENDIX E – ACCESSORIES

Reflex Marine Ltd provides a range of flexible accessories to optimise the use of the FROG-3.



Skid Trolley

Specially designed trolley for ease of movement of the FROG-3 to areas that are undercover or otherwise outside the normal reach of the crane and for ease of storage. The skid trolley features caster wheels and a parking brake.



Strobe Light

Provides greater visibility in poor weather conditions. High-intensity: light weight, waterproof to 300 m, Flash Rate 50 per min and also provides 6 mile visibility. C cell battery powered, fitted to central column of FROG-3.

Note: The strobe is not certified for use in hazardous areas.



Stretcher (MedEvac)

Essential for conducting emergency medical transfers, Reflex Marine Ltd supply rigid stretcher that are compliant to use in FROG-3 emergency stretcher mode.



Protective Cover

The cover protects against degradation from UV light and the weather elements as well as worksite debris. It is adjustable for either standard or emergency configuration of the FROG-3. The silver reflective cover is made of flame resistant fabric (BS3408).



Rigid Luggage Box

The fitted rigid luggage box offers 60 litres capacity for loose items such as hand tools and equipment cases. Moulded box fits into the buoyancy recess and is easily fitted.





Multi-Lingual Operational Briefing DVD's

The FROG-3 is supplied with Multi-Lingual Operational Briefing DVD's in English, French, Spanish, Portuguese and Russian. Additional copies can be ordered through www.reflexmarine.com/support.

14 APPENDIX F – INDEPENDENT CERTIFICATION

14.1 EC Type examination certificate (from unit number FS 412 onwards)

 L A I D L E R CERTIFICATION			
Tel +44 (0) 8700 111375	Fax +44 (0) 8700 111395	E-mail enquire@laidler.co.uk	Web www.laidler.co.uk
EC TYPE EXAMINATION CERTIFICATE			
<p>EC type-examination requested by:</p> <p>Manufacturer: Reflex Marine Ltd</p> <p>Address: Somar House, Heron Way, Truro, TR1 2XN, UK</p> <p>Responsible Person: Andrew Grimes</p> <p>Date of submission: 31st January 2011</p> <p>Machinery description:</p> <p>Machine: Frog 3 Personnel Transfer Capsule (PTC)</p> <p>Model: FS-01</p> <p>Series: 320, 340 and 370</p> <p>Serial No. (Inspected item): FS-XXX</p> <p>Conclusions of examination The machinery specified above has been examined and found to comply with the essential safety requirements specified in the EC Machinery Directives 2006/42/EC.</p> <p>Special Conditions Special conditions applicable to the issue of this certificate are given in Appendix 1: None</p> <p>Conditions of Issue. This certificate refers to the information examined only. Any modifications made subsequent to the examination of the documentation unless they are submitted to Laidler Certification for approval will nullify this certificate.</p> <p>Signed:  _____ Date: 28th February 2011 Certification Manager/Operations Manager</p> <p style="text-align: center;">CE</p> <p style="display: flex; justify-content: space-between;"> Notified Body No. 0870 Certificate No: 0600/CC1015 </p>			
LAIDLER CERTIFICATION LLP, BELASIS BUSINESS CENTRE, COXWOLD WAY, BILLINGHAM, CLEVELAND, UK, TS23 4EA Ref: Doc.No. 4.3(a)/MD/PL Page 1 of 1 Rev: 01/11.02 <small>Directors: P Laidler, M Swales, D Coulson. Company Registration no. 0010193. Notified and Competent Body No. 0870</small>			

14.2 ABS Product Design Assessment Certificate (from unit number FS 412 onwards)

Electronically published by ABS London.
Reference 758865, dated 20-MAY-2011.



CERTIFICATE NUMBER
11-LD758865-PDA

DATE
20 May 2011

ABS TECHNICAL OFFICE
London Engineering Department

CERTIFICATE OF DESIGN ASSESSMENT

This is to Certify that a representative of this Bureau did, at the request of
REFLEX MARINE LTD

assess design plans and data for the below listed product. This assessment is a representation by the Bureau as to the degree of compliance the design exhibits with applicable sections of the Rules. This assessment does not waive unit certification or classification procedures required by ABS Rules for products to be installed in ABS classed vessels or facilities. This certificate, by itself, does not reflect that the product is Type Approved. The scope and limitations of this assessment are detailed on the pages attached to this certificate.

PRODUCT: Offshore Personnel Transfer Device (personnel baskets)

MODEL: FS-01 (320) Standard Frog 3, FS-01 (340) Arctic Frog 3, FS-01 (370) Tropical Frog 3

This Product Design Assessment (PDA) Certificate 11-LD758865-PDA, dated 20/May/2011 remains valid until 19/May/2016 or until the Rules or specifications used in the assessment are revised (whichever occurs first).

This PDA is intended for a product to be installed on an ABS classed vessel, MODU or facility which is in existence or under contract for construction on the date of the ABS Rules or specifications used to evaluate the Product.

Use of the Product on an ABS classed vessel, MODU or facility which is contracted after the validity date of the ABS Rules and specifications used to evaluate the Product, will require re-evaluation of the PDA.

Use of the Product for non ABS classed vessels, MODUs or facilities is to be to an agreement between the manufacturer and intended client.

AMERICAN BUREAU OF SHIPPING



John L. Morgan
Engineer

NOTE: This certificate evidences compliance with one or more of the Rules, Guides, standards or other criteria of ABS or a statutory, industrial or manufacturer's standard. It is issued solely for the use of ABS, its contractors, its clients or other authorized entities. Any significant changes to the abovespecified product without approval from ABS will result in this certificate becoming null and void. This certificate is governed by the terms and conditions as contained in ABS Rules 1-1-ABS 9 Terms and Conditions of the Request for Product Type Approval and Agreement (2010)

ABS0110