



Repeater Compass

Type **133-560 NG011 to NG017**

Operator and Service Manual



Dieses Dokument sowie dessen Inhalt sind urheberrechtlich geschützt. Die Weitergabe, Vervielfältigung und Speicherung sowie die Übersetzung wie auch Verwendung dieses Dokuments oder dessen Inhalts, als Ganzes oder in Teilen und egal in welcher Form, ist ohne vorherige ausdrückliche schriftliche Genehmigung nicht gestattet. Zuwiderhandlungen verpflichten zu Schadenersatz.

Änderungen dieses Dokuments und dessen Inhalt bleiben vorbehalten.

This document and its content are copyright protected. Distribution, reproduction and storage as well as translation and exploitation of this document and its content, in whole or in parts and regardless of what form, are prohibited without prior express written permission. Offenders will be hold liable for the payment of damages.

Changes and modification to this document and its content reserved.

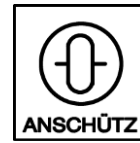

Table of Content

TABLE OF CONTENT	I
TABLE OF FIGURES	II
TABLE OF TABLES	II
SAFETY INSTRUCTIONS	III
ABBREVIATIONS/ACRONYMS	IV
CHANGE HISTORY	V
1 DESCRIPTION	1-1
1.1 General	1-1
1.2 Construction	1-2
1.2.1 Front panel	1-2
1.2.2 Principle of operation	1-3
1.2.3 Function key (overview)	1-4
1.3 Technical data	1-7
1.3.1 Dimensions and weight	1-7
1.3.2 Mechanical data	1-7
1.3.3 Electrical data	1-7
1.3.4 Serial input	1-7
2 OPERATION OF THE REPEATER COMPASS, TYPE 133-560	2-1
2.1 Structure of operation and configuration	2-1
2.2 Indications	2-2
2.2.1 Analogue heading indication	2-2
2.2.2 Digital heading display	2-3
2.2.3 Heading source indication	2-3
2.2.4 Status and alarm indications	2-4
2.3 Notes on the operating instructions	2-5
2.4 Switching on the Repeater Compass	2-6
2.5 Indication of the Repeater Compass after setting into operation	2-7
2.6 Signals during operation	2-8
2.7 Additional operations during normal mode	2-9
2.7.1 Dimming	2-9
2.7.2 Central Dimming	2-10
2.7.2.1 Central Dimming via NMEA	2-10
2.7.2.2 Central Dimming via CAN Bus	2-10
2.7.3 Test mode and actual configuration/status information	2-11
2.8 Configuration/status adjustment	2-14
2.8.1 Possible configuration errors	2-19
2.8.2 Central Dimming	2-20
2.8.2.1 Central Dimming via NMEA	2-20

Repeater Compass 133-560

2.8.2.2	Central Dimming via CAN Bus	2-21
2.9	Correction of the analogue indications (cards).....	2-22
2.10	Fault operation.....	2-23
2.11	Switching off the Repeater Compass.....	2-23
3	INSTALLATION OF THE REPEATER COMPASS	3-1
3.1	General.....	3-1
3.1.1	Mounting of the Repeater Compass	3-2
3.1.2	Electrical installation of the Repeater Compass	3-3
3.2	First setting into operation.....	3-4
4	MAINTENANCE AND SHIPBOARD REPAIR	4-1
4.1	Maintenance	4-1
4.2	Shipboard repair	4-1
4.2.1	General.....	4-1
4.2.2	Measures in case of alarms on the Repeater Compass.....	4-2
5	DISPOSAL	5-1

Table of Figures

Figure 1-1	View of the front panel of the Repeater Compass	1-1
Figure 1-2	Operating and indicating elements on the front panel of the Repeater Compass	1-2
Figure 2-1	Three line indicator.....	2-3
Figure 3-1	Cable connection of the Repeater Compass	3-3

Table of Tables

Table 1-1	Overview of drawings for technical data	1-7
Table 2-1	LED signalling	2-4
Table 2-2	Used symbols in this manual.....	2-5
Table 3-1	Cable connection of the Repeater Compass	3-4

Parts Catalogue

14.718 RAN/VSI-BEH 0513 EDITION 04

Drawings:

Dimensional Drawing (standard) (IP23/56)	133-560. HP025
Dimensional Drawing (bulkhead mounting) (IP44)	133-560. HP028
Dimensional Drawing (wall mounting) (IP44)	133-560. HP030
Dimensional Drawing (bulkhead mounting) (IP56)	133-560. HP032
Dimensional Drawing (flush mount. + casing) (IP56)	133-560. HP034
Dimensional Drawing flush mount. + frame) (IP56)	133-560. HP036
Connection Diagram	133-560. HP027

Safety instructions



Warning!

Make sure that the gyro compass has settled before using its heading data.



Warning!

Always check the plausibility of the indicated heading against other heading sources / navigational aids.



Warning!

Mechanical or electrical changes to the device are strictly forbidden.



Caution!

Installation, maintenance and configuration must be carried out only by properly trained and qualified staff with a good knowledge of national equipment safety regulations.

**Repeater Compass
133-560**

Abbreviations/Acronyms

Appr. Approx.	Approximately
Bd	Baud, Baud rate
CAN	Computer Area Network
CF CON	Configuration
CoR	Correction
G AL	Gyro Alarm
GND	Ground
G M	Gyro or magnetic compass
GPHDT	NMEA telegram: Heading True from a satellite compass
G GYRO	Gyro compass
HCHDM	NMEA telegram: Heading Magnetic
HCHDT	NMEA telegram: Heading True from a magnetic compass
HDT	NMEA telegram: Heading True
HP	Auxiliary paper (<u>Hilfs</u> Papier)
HSEr HSER	Heading Serial
M Mag	Magnetic compass
IEC	International Electrotechnical Commision
IP	Internal Protection
LED	Light Emitting Diode
NG	Standard device (<u>Norm</u> Gerät)
NMEA	National Marine Electronic Association
PCB PC- board	Printed Circuit Board
RS	Recommended Standard (US Standard)
Rx	Receive
SCI	Serial Communication Interface
Sat	Satellite compass
V DC	Voltage Direct Current
W	Watt



Change History

Date	Change
May 30, 2013	New edition
July 01, 2014	Update of Spare Parts Catalogue
August 2014	CAN Bus operation added

**Repeater Compass
133-560**

Intentionally left blank

1 Description

1.1 General

The Repeater Compass, Type 133 - 560, shows the heading from a compass. The heading is indicated by a 360° and a 10° card.

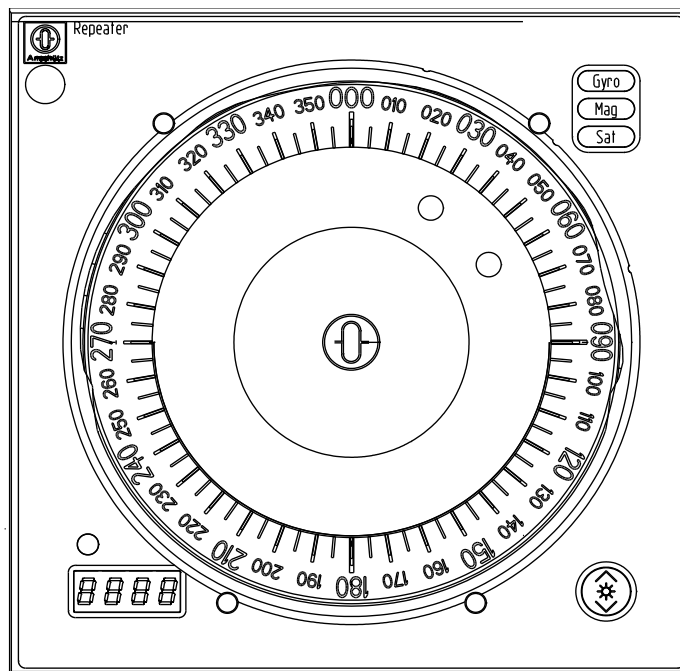

Figure 1-1 View of the front panel of the Repeater Compass

The Repeater Compass is designed to indicate heading from magnetic, gyro or satellite compasses (or Transmitting Heading Devices – THDs) via a serial interface (Course BUS*, NMEA or a CAN Bus*).

It can be configured to indicate the selected heading (from a heading management system or INS) or to indicate one heading source (gyro/satellite or magnetic compass) permanently and independent from the selected heading source if Course Bus is used.

In addition the Steering Repeater can be configured to indicate alerts (acoustical and optical) if connected via Course Bus to a Standard 22 Compact.

Other useful features are a 180° heading offset (e.g. for aft workstation) or a central dimming function (if part of a Standard 22 Compass system or NautoSteer AS) via CAN Bus or via NMEA.

Each application has to be configured according to section 2.8.

*) "Raytheon Anschütz" specific

Repeater Compass 133-560

1.2 Construction

1.2.1 Front panel

An anti-reflective screen covers the cards on the front panel of the Repeater Compass. The lubber line is inside the plate.

LEDs illuminate the lubber line and the cards in an area of $\pm 55^\circ$. In the lower area of the front plate on the left side (refer to Figure 1-2) a LED can light up in one of three colours (red, yellow, green) and shows alarm (red), proper function (green) or restricted function (yellow).

Below the LED there is a digital display for the indication of the heading, error messages and configuration status.

On the right side there is a multiple function key.

At the top of the front plate there is a three line display to show the source of the heading information.

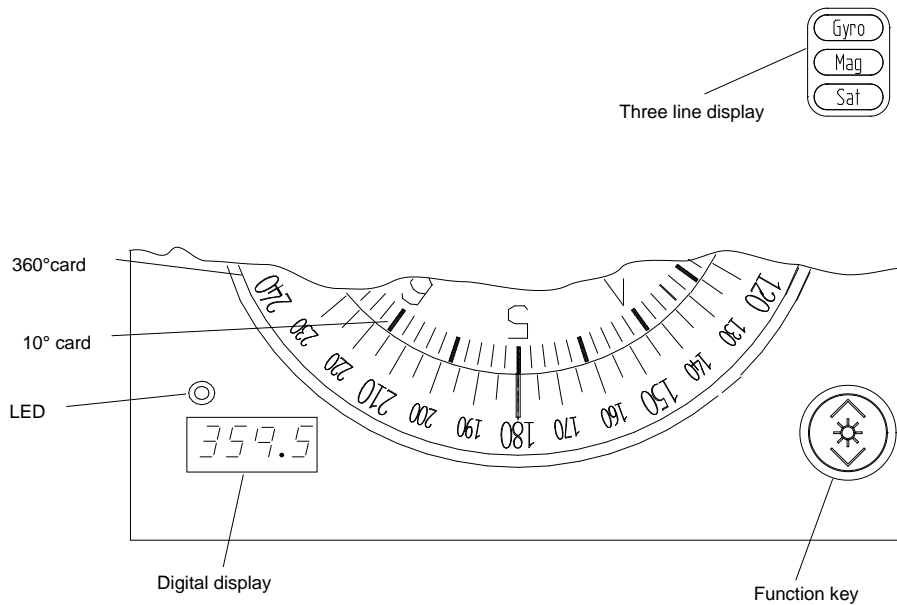
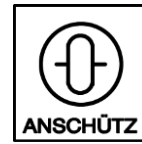

Figure 1-2 Operating and indicating elements on the front panel of the Repeater Compass



1.2.2 Principle of operation







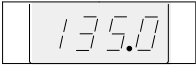

The Repeater Compass receives the heading information from a gyro compass from a magnetic compass or from a satellite compass by means of serial heading transmission with absolute and clear values.

The heading transmission is realized via a serial interface (RS422, RS232C, CAN Bus*) using NMEA, Course Bus* or CAN Bus messages*.

*) "Raytheon Anschutz" specific

Repeater Compass 133-560

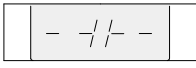
1.2.3 Function key (overview)

	Comments, notes
  approx. 11 seconds ↓   max. brightness approx. 3 seconds ↓   approx. 2 seconds ↓  	<p>Normal operation Dim mode (see sections 2.5 to 2.7)</p> <p>Test and actual configuration/status (see section 2.7.3)</p> <p>Configuration (see section 2.8)</p> <p>Correction (see section 2.9)</p>

Various functions can be selected via the multiple-function key on the right side of the front panel:



Please note:

After a function is selected (except “DIMMING”) the normal mode is displayed after approx. 4 seconds (timeout) when the key is released.

- 1. Function: DIMMING (see section 2.7.1)

This function is available in the normal operation mode.

It is not specially indicated.

With the key the setting can be made darker, brighter and can be switched off (except the function key itself).



Please note:

If the Repeater Compass is configured as CAN Bus Repeater the external central dimming is capable in both directions.

- 2. Function: TEST (see section 2.7.3)

This function is activated by operating the key (into max. brightness direction) for approx. 11 seconds until the display shows **8888**.

After releasing the key, the test runs on its own.



The dimming of all displays and lighting, the completeness of the digital display and the function of the analog displays is tested.

The test lasts approx. four seconds.

The buzzer can be tested if the repeater is configured as a G-AL (AL = indicate alerts (acoustical and optical) if connected via Course Bus to a Standard 22 Compact, see section 2.7).

After a short release of the multiple-function key and an activation again the adjusted configurations are displayed (one after another with each key operation, see section 2.7.3).

Repeater Compass 133-560

- 3. Function: CONFIGURATION (see section 2.7)
The configuration mode is activated by operating the key (into max. brightness direction) for approx. 14 seconds until  is indicated.
To activate the configuration mode it is necessary to operate the key in that manner that the brightness of the display increases. After the  is displayed the configuration adjustment can be performed by a short release of the key followed by selection of the configuration parameters with every operation of the key. Active configurations are flashing; non-active configurations light up permanently.

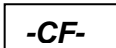
- 4. Function: CAN Bus address
The CAN Bus address mode is activated by operating the key for approx. five seconds (into max. brightness direction) after the configuration display  is shown.

- 5. Function: CORRECTION of the Analogue Indications (Cards) (see section 2.8).



Please note:

The analogue indications are adjusted by the manufacturer.

A correction of the analogue indications is not needed in normal operation. The correction is required in the case of de-synchronization of the analogue and digital display only.

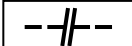
The correction mode is selected by operating the key for approx. 16 seconds until  is displayed.

After activation of this function the Repeater Compass corrects itself first and after this automatically correction a manually procedure to correct the “zero-position” in correspondence to the lubber line can be performed by operating the key.

This procedure is for the 360° and the 10° card separately.

Approx. 10 seconds after the last card adjustment the “CORRECTION” function is completed and the current settings are stored.



1.3 Technical data

1.3.1 Dimensions and weight

For dimensions, weights and types of enclosures refer to the dimensional drawings in the annex.

Below mentioned drawings contain all necessary data.

Table 1-1 Overview of drawings for technical data

No.	Part No.	Drawing No.	Designation	Type of Enclosure
1	133-560 NG011	133-560.HP025	Repeater Compass for flush mounting (standard)	(IP23/56)
2	133-560 NG013	133-560.HP028	Repeater Compass for bulkhead mounting	(IP44)
3	133-560 NG014	133-560.HP030	Repeater Compass for wall mounting	(IP44)
4	133-560 NG015	133-560.HP032	Repeater Compass for bulkhead mounting	(IP56)
5	133-560 NG016	133-560.HP034	Repeater Compass for flush mounting + casing	(IP56)
6	133-560 NG017	133-560.HP036	Repeater Compass for flush mounting + frame	(IP56)

1.3.2 Mechanical data

Reading accuracy: 0.1°

1.3.3 Electrical data

Supply voltage: 18 - 36 V_{DC}
 Power consumption: max. 8 W
 Interfaces: RS 422 / RS232C,
 CAN Bus*
 Course Bus*

1.3.4 Serial input

4800 Baud – 38.4 kBaud
 (automatic detection)
 1 start bit, 1 stop bit
 no parity

Telegrams according to NMEA refer to IEC 61162-1.

*Raytheon Anschütz specific

**Repeater Compass
133-560**

Intentionally left blank

2 Operation of the Repeater Compass, type 133-560

2.1 Structure of operation and configuration

RS422 (RS232C) Heading Serial Structure (Course Bus or NMEA)

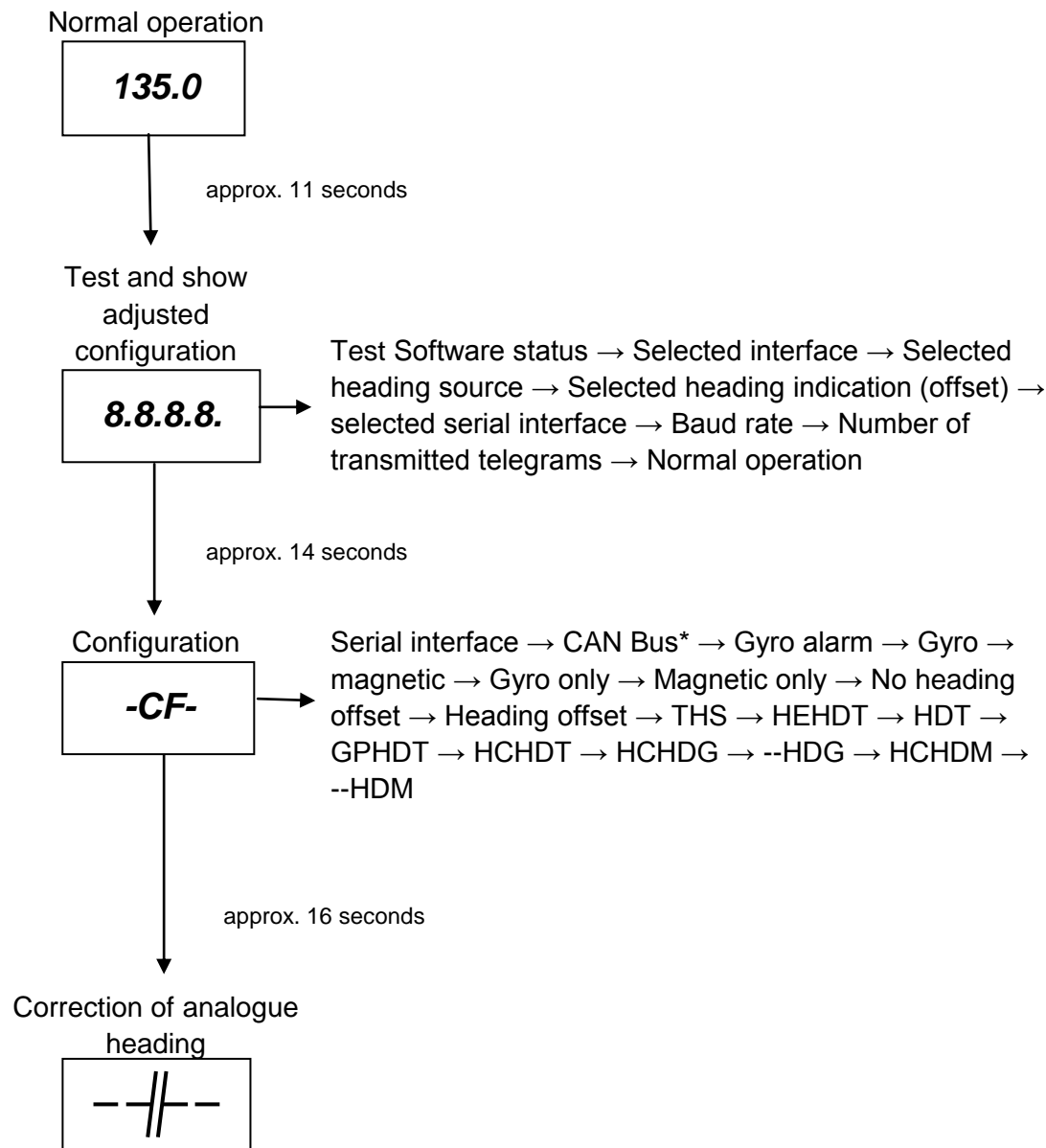

*Raytheon Anschütz specific

CAN Bus Structure

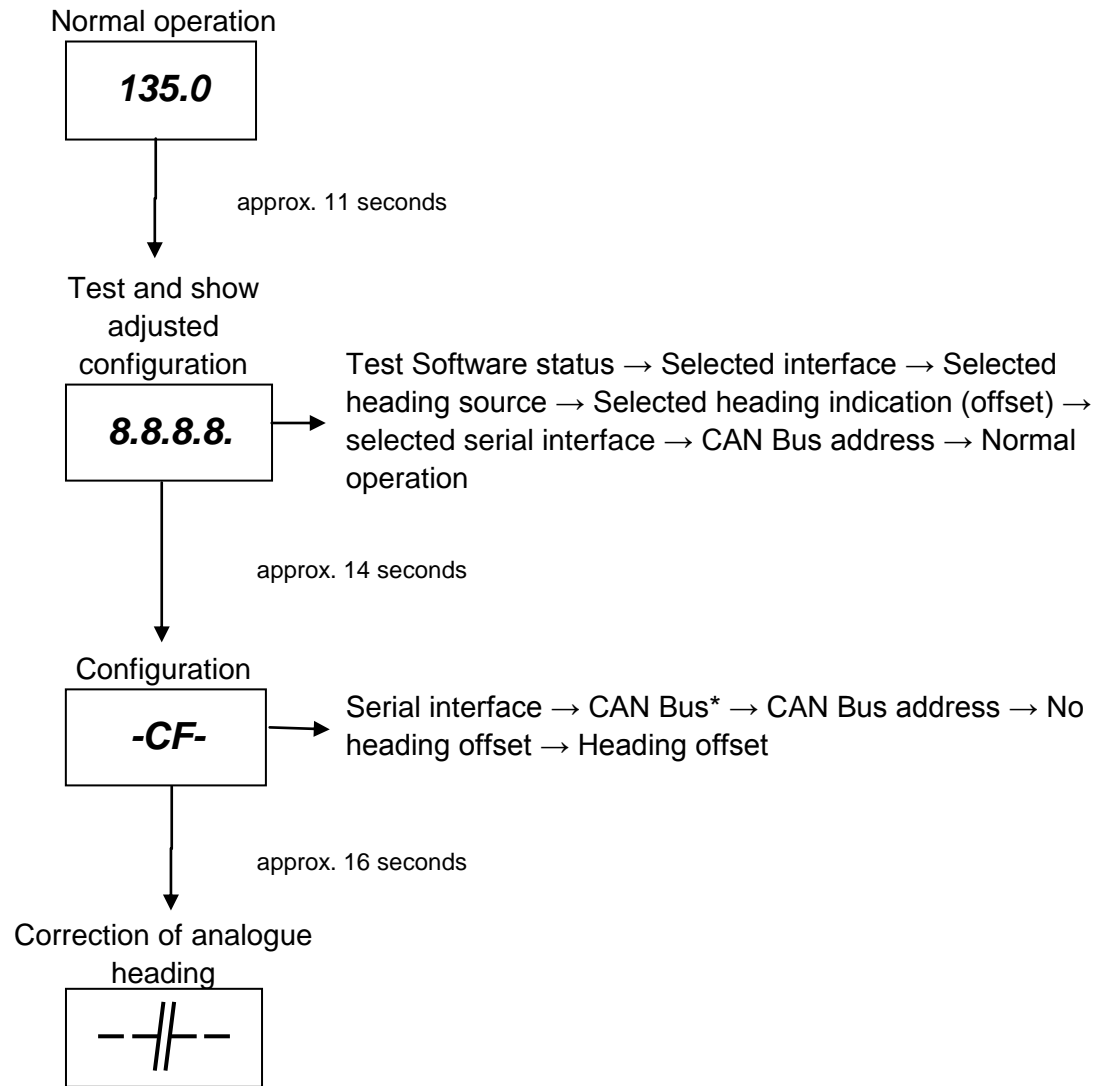

2.2 Indications

2.2.1 Analogue heading indication

The serial heading information is converted into steps on the Repeater Compass PCB for the stepping motors. The stepping motors turn the 360° and the 10° card.

*Raytheon Anschütz specific

2.2.2 Digital heading display

In addition to the analogue heading indication by the cards, the Repeater Compass is also equipped with a digital heading display on the left side of the front panel.

2.2.3 Heading source indication

Additional there is a heading source indication (Three line indicator) at a top right position of the front panel. It shows “Gyro”, “Mag”, or “Sat” according to the source of the heading information. It is equipped with three LEDs; these LEDs are controlled by the header of the NMEA Telegrams or by the heading source information of the course- and CAN Bus.



Figure 2-1 Three line indicator

*Raytheon Anschütz specific

Repeater Compass 133-560

2.2.4 Status and alarm indications

The digital display also reports any possible error or alarm by means of a preset display code (refer to section 4.2.2). If the Repeater Compass is configured as G-AL the optical alarm is supported by a buzzer (for detailed information see section 3).

A LED on the left side of the front panel signalizes the status or alarm of the Repeater Compass and of the telegram:

Table 2-1 LED signalling

No.	LED	NMEA interface	CAN / Heading Serial interface
1	green	Repeater Compass is available and the telegram is ok.	Gyro Compass is available. Satellite compass is available.
2	red	Gyro Compass is defective. Satellite compass is defective. Missing data communication to compass.	Gyro Compass is defective. Satellite compass is defective. Missing data communication to compass.
3	yellow	During correction of the analogue indication (heading). During configuration of the Repeater Compass.	Settling phase of the Gyro Compass.



Please note:







For NMEA telegram "THS" status indication with respect to the LED at the front plate, see 2.8.

2.3 Notes on the operating instructions

Follow step by step the operating procedure shown in the corresponding sections. If necessary, helpful information in short form has been added to the figurative representation (symbols).

Explanation of the manual symbols:

Table 2-2 Used symbols in this manual

Symbol	Meaning
	Key operation
	Action, general
	LED off
	LED on
	LED flashes
	Audible signal on
	Audible signal off



2.4 Switching on the Repeater Compass

When the supply voltage is switched on, the Repeater Compass is set into operation. An automatic synchronization follows.

The current heading is shown by the analogue and digital indications.

The heading sensor source is indicated by a three-line display at the top right of the front plate.

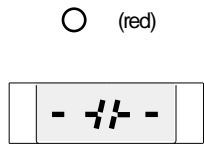
If the Repeater Compass is switched on and there is no interface connected, the messages below are indicated:

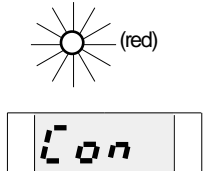
Indications	Comments, notes
 <p style="text-align: center;">○ (red)</p> <p style="text-align: center;">- 000 -</p>	<ul style="list-style-type: none"> - LED lights up red - The display indicates "  " - The cards adjust to 0° - The display indicates "  "
 <p style="text-align: center;">☀ (red)</p> <p style="text-align: center;">Con</p>	<ul style="list-style-type: none"> - After approx. 10s the display indicates "Con" flashing (refer to section 4.2.2) - The LED flashes red <p>Optional: Audible alarm signal (buzzer) - acknowledge by operating the key (only if the Repeater Compass is configured as G-AL.)</p>

In this case the measures described in section 4.2.2 are required.

2.5 Indication of the Repeater Compass after setting into operation

If the Repeater Compass is connected via NMEA it indicates the heading source and heading value. Please note that the Repeater Compass only indicates heading if it receives a valid NMEA telegram, e.g. after the settling phase.

If the Repeater Compass is connected via Course Bus or CAN Bus the indication is as follows:



During the heating stage of Standard 22 (approx. 0.5 h after setting the compass into operation) there is no heading indication at the Repeater Compass.

After the heating stage has ended the settling stage of the gyro compass starts. This is indicated by a yellow LED.

During this settling stage the heading is indicated. Please note that the heading during the settling phase is it is not true north. It must not be used for navigation purposes.

Only when the settling phase has ended (after approx. 4 h) the heading indication has the assured accuracy.



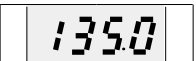



(See also the manual for the gyro compass).

Indications	Comments, notes
<p style="text-align: center;">○ (red)</p> 	<p>Heating stage (and alignment stage of the Satellite compass) :</p> <ul style="list-style-type: none"> - LED lights up red - Horizontal lines on the digital display
<p style="text-align: center;">○ (yellow)</p> 	<p>Settling stage:</p> <ul style="list-style-type: none"> - LED lights up yellow - Numerical heading indication (a point is displayed at the end of the displayed value during the settling stage)
<p style="text-align: center;">○ (green)</p> 	<p>Normal operation:</p> <ul style="list-style-type: none"> - LED lights up green - Numerical heading indication after end of the settling phase, heading is available

Repeater Compass 133-560

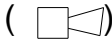

2.6 Signals during operation

During normal operation the heading is indicated by the display and the cards. In addition to the heading value on the digital display the source of the heading information is shown with a 3-line display at the top right of the front plate. The heading source light up green ("Gyro", "Mag" or "Sat").

Indications	Comments, notes
Valid heading from the gyro, magnetic or satellite compass	
 (green) 	<ul style="list-style-type: none"> - LED lights up green. - The three-line display shows the heading source.
No valid heading	
 (red)    	<ul style="list-style-type: none"> - LED lights up red - horizontal lines on the digital display - after approx. 10s the LED and "Con" are flashing <p>Please note: Only if this repeater is configured as "G-AL" (Heading Serial → HSER) the audible alarm signal is active.</p> <ul style="list-style-type: none"> - for buzzer off - press  key

2.7 Additional operations during normal mode

2.7.1 Dimming

	Indications	Comments, notes
		<p>Continuous brightness adjustment of</p> <ul style="list-style-type: none"> - the scale illumination - the display illumination - 3-line display - Status LED - Function key <p>With the first operation of the key the brightness will increase. After a short release of the key and operating it again, the brightness decreases. After min. brightness is adjusted and the key is pressed for additional approx. 3 seconds all illumination is switched off (except the key itself). If an alarm occurs the LED lights up with min. brightness after illumination is switched off.</p>



Please note:

If there is an alarm present, the illumination cannot be dimmed to zero (switched off).

2.7.2 Central Dimming

2.7.2.1 Central Dimming via NMEA

The Repeater Compass is prepared to accept a DDC (device dimming control) telegram according to IEC 61162-1. If this telegram is input to the Repeater Compass (e.g. created from a central dimmer – no Raytheon Anschütz supply) the brightness is adjusted according to the brightness percentage of the telegram.

2.7.2.2 Central Dimming via CAN Bus









If connected to CAN Bus the Repeater Compass can also be centrally dimmed (dependent on the configuration). In this case the dimming value is defined by a component of the NautoSteer AS Steering Gear Control System. The Repeater Compass can also act as a central dimmer, meaning that other devices of NautoSteer AS follow the dimming value of the Repeater Compass.

Precondition for this function is that the receiver and the transmitter of the telegram are assigned to the same dimming group.







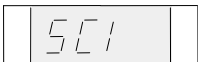





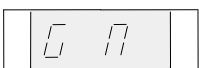





2.7.3 Test mode and actual configuration/status information

With the operations described below the test mode is started and by operating the key essential configurations or status information can be displayed.
For changing configuration see section 2.8.





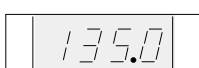





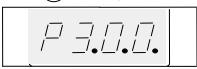

RS422 (RS232C) Heading Serial Operation (NMEA or course bus)

	Indications	Comments, notes
	<p>○ (yellow)</p>   	<p> Do not operate the key too long: approx. 3 seconds after test mode is selected, another mode (-CF-) is started</p> <p>Operate key until</p> <ul style="list-style-type: none"> - display indicates '8.8.8.8.' <ul style="list-style-type: none"> - the cards, the key, the luminous panels, the three-colour LED, the three-line display and the digital display will light up with maximum brightness. <p>With configuration of the unit as steering Repeater Compass an audible signal is emitted (continuous sound) only when the Repeater Compass is connected direct to a gyro compass.</p>
 Operate key 1x	<p>○ (yellow)</p> 	Software status (shown example only)
 Operate key 2x	<p>○ (yellow)</p> 	<p>Selected interface type:</p> <p>SCI = Serial controlled interface (as shown)</p>

Repeater Compass 133-560

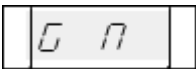
	Indications	Comments, notes
 Operate key 3x	 (yellow) 	Selected heading source: G AL = Gyro alarm G M = Gyro or magnetic compass (as shown) G - = Gyro compass only M - = Magnetic compass only <u>Please note:</u> "G" means also a heading from a satellite compass. Except "G AL", this heading source is for direct gyro compass connection only.
 Operate key 4x	 (yellow) 	Heading indication: 000° = for normal operation (as shown) 180° = turned by 180° (e.g. for ferries)
 Operate key 5x	 (yellow) 	Type of serial interface: NMEA = NMEA telegram (as shown) HSEr = Heading serial (course bus RAYTHEON Anschutz specific)
 Operate key 6x	 (yellow) 	Baudrate (automatically detected). Shown baud rate is: 38,400 Bd
 Operate key 7x	 (yellow) 	Number of received telegrams per second. Shown is: 28 telegrams per second
	 (green)  	End the test by operating the key or Test mode ends automatically after approx. three seconds of no operation of the key

CAN Bus operation

	<p>Indications</p>	<p>Comments, notes</p>
	<p>○ (yellow)</p> 	<p> Do not operate the key too long: approx. 3 seconds after test mode is selected, another mode (-CF-) is started</p> <p>Operate key until</p> <ul style="list-style-type: none"> - display indicates '8.8.8.8.' - the cards, the key, the luminous panels, the three-colour LED, the three-line display and the digital display will light up with maximum brightness.
 Operate key 1x	<p>○ (yellow)</p> 	<p>Software status (shown example only)</p>
 Operate key 2x	<p>○ (yellow)</p> 	<p>Selected interface type:</p> <p>Can = CAN Bus interface</p>
 Operate key 3x		<p>"G_M_"</p> <p>Heading can be transmitted from a gyro, magnetic or satellite compass.</p> <p>Standard configuration if connected to CAN Bus.</p>
 Operate key 4x	<p>○ (yellow)</p> 	<p>Heading indication (no offset)</p>
 Operate key 5x		<p>CAN Bus address:</p> <p>Possible CAN Bus addresses: 30 – 63.</p>



Please note:

If more than one Repeater Compass is connected to the CAN Bus, different CAN Bus addresses are required.

2.8 Configuration/status adjustment

The sequence and the meaning of the available parameters to configure are shown in the table below.

A selected parameter can be activated by holding the key operated until the parameter blinks.

Multiple selections of parameters are possible.



Caution!

Switch off the power supply of the Repeater Compass after finishing the configuration and restart it. During the restart the Repeater Compass checks the validity of the configuration.



Please note:









Possible configuration errors are shown in section 2.8.1.





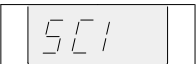







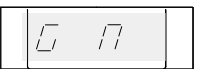

Caution!













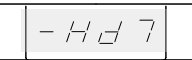

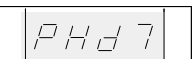

Configure the Repeater Compass very carefully. A false or invalid configuration leads to malfunction and error indications.

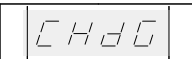
RS422 (RS232C) Heading Serial (NMEA or Course Bus)

Current No.	Indications	Comments, notes
 Operate key	<p>○ (yellow)</p> 	 Do not operate the key too long: approx. 6 seconds after configuration mode is selected, another mode (Addr.) is started Operate key until - display indicates "-CF-" With a short release of the key and an operation of the key again, the first parameter to configure is displayed.
 Operate key 1x		<p>"SCI_" Serial Communication Interface</p> <p>It can be NMEA or course bus (Raytheon Anschütz specific) format. The Repeater Compass detects automatically the type of interface.</p>
<div style="border: 1px solid black; padding: 10px;">  <p>Please note: The change of the CAN Bus interface type is effected only after switching off and on again (after completion of the configuration).</p> </div>		
 Operate key 2x		<p>"CAn_" CAN Bus interface CAN Bus is automatically terminated if selected.</p>
<div style="border: 1px solid black; padding: 10px;">  <p>Please note: The change of the CAN Bus interface type is effected only after switching off and on again (after completion of the configuration).</p> </div>		

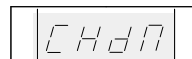

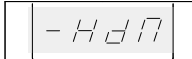

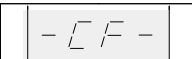





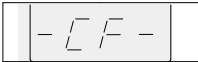

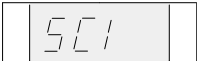

Repeater Compass 133-560

Current No.	Indications	Comments, notes
 Operate key 3x		<p>"G_AL" = Gyro alarm (Course bus only)</p> <p>Repeater Compass (with an audible alarm function) directly connected to a gyro compass (for systems where alarms are not shown on a gyro compass operator unit).</p> <p>Alarms are possible only when connected to a gyro compass or a magnetic compass (Course bus). However, heading is displayed for all connected heading sources.</p> <p>Alarm procedures/connections see also section 3.</p> <p>Note: "G" means Gyro only, in this case <u>not</u> satellite compass</p>
 Operate key 4x		<p>"G_M_"</p> <p>Heading can be transmitted from a gyro, magnetic or satellite compass.</p> <p>Operating with NMEA, only one telegram must be activated.</p>
 Operate key 5x		<p>"G_-"</p> <p>Heading is transmitted from a gyro or satellite compass.</p>
 Operate key 6x		<p>"M_-"</p> <p>Heading is transmitted from a magnetic compass only.</p>
 Operate key 7x		<p>Normal heading indication (no offset).</p>
 Operate key 8x		<p>Heading indication shifted by 180° (offset for special applications).</p>
 Operate key 9x		<p>NMEA telegram "--THS" – accepts true heading and status (THS) from gyro, satellite and magnetic compasses, the respective source is indicated</p> <p>These three different status are: Autonomous = normal transmitted heading without any restrictions, LED = green Estimated heading (dead reckoning) = LED yellow Manual heading input = LED yellow Simulation mode = LED yellow Data not valid (including stand by) = LED red</p>

Current No.	Indications	Comments, notes
 Operate key 10x		"EHdT" NMEA telegram "EHdT" - heading true Heading transmitted from gyrocompass.
 Operate key 11x		"-HdT" NMEA telegram "--HDT" – accepts true heading (HDT) from gyro, satellite and magnetic compasses, the respective source is indicated.
 Operate key 12x		"PHdT" GPS Telegram "GPHDT" - Satellite compass, heading true Heading transmitted from a satellite compass.
 Operate key 13x		"CHdT" Magnetic compass telegram "HCHDT" - heading magnetic. Heading transmitted from a magnetic compass (heading corrected).
 Operate key 14x		"CHdG" Magnetic compass telegram "HCHDG" - heading magnetic Heading transmitted from a magnetic compass (uncorrected).
 Operate key 15x		"-HdG" NMEA telegram "--HDG" - accepts heading from a magnetic sensor (HDG) and does not consider the talker identifier.
 Operate key 16x		"-CHdM" Magnetic compass telegram "HCHDM" - heading magnetic Heading transmitted from any magnetic compass.
 Operate key 17x		"-HdM" Magnetic compass telegram "--HDM" accepts heading from a magnetic sensor (HDM) and does not consider the talker identifier.
 Operate key 17x	○ (yellow) 	End / beginning of configuration mode.

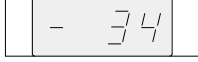
Repeater Compass 133-560







CAN Bus

Current No.	Indications	Comments, notes
 Operate key	○ (yellow) 	 Do not operate the key too long: approx. 6 seconds after configuration mode is selected, another mode (Addr.) is started Operate key until - display indicates “-CF-” With a short release of the key and an operation of the key again, the first parameter to configure is displayed.
 Operate key 1x		“SCI_” Serial Communication Interface
<div style="border: 1px solid black; padding: 10px;">  <p>Please note: The change of the CAN Bus interface type is effected only after switching off and on again (after completion of the configuration).</p> </div>		
 Operate key 2x		“CAN_” CAN Bus interface CAN Bus is automatically terminated if selected.
<div style="border: 1px solid black; padding: 10px;">  <p>Please note: The change of the CAN Bus interface type is effected only after switching off and on again (after completion of the configuration).</p> </div>		
 Operate key 3x		Next CAN Bus address
 Operate key 4x		Enter address by operating the key: Release the key to change the direction (plus or minus).
Wait		Wait approx. 10 seconds to change to normal heading indication (no offset).
 Operate key		Heading indication shifted by 180° (offset for special applications).

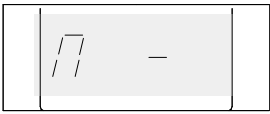

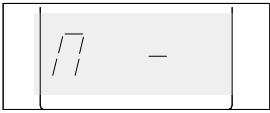
Please note that the Repeater Compass always indicates the selected heading if connected via CAN Bus.

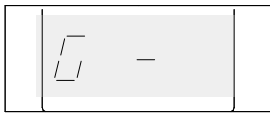
2.8.1 Possible configuration errors

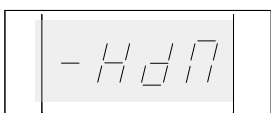
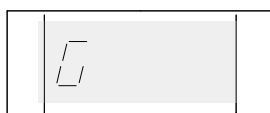
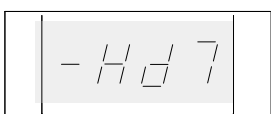
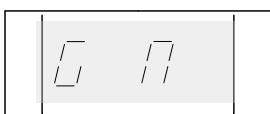
		<p>“EHDT”: Heading transmitted from gyrocompass but magnetic compass is selected. There will be no heading indication.</p>
		<p>“PHDT”: Heading transmitted from Satellite compass but magnetic compass is selected. There will be no heading indication.</p>
		<p>“CHDT”: Heading transmitted from magnetic compass but Gyro or Satellite compass is selected. There will be no heading indication.</p>
		<p>“-HdG”: Heading transmitted from magnetic compass but Gyro or Satellite compass is selected. There will be no heading indication.</p>
		<p>“-HdM”: Heading transmitted from magnetic compass but Gyro or Satellite compass is selected. There will be no heading indication.</p>
		<p>“--HDT”: Heading transmitted from gyrocompass without “talker”: Heading from alternating sources can be displayed if a Gyro and a magnetic compass are connected. It is as well possible, that there is no heading indication. Only one heading source should be connected.</p>

2.8.2 Central Dimming

The central dimming function is included since software version 133-560.P0003 E00.04.

2.8.2.1 Central Dimming via NMEA

The Repeater Compass is prepared to accept a DDC (device dimming control) telegram according to IEC 61162-1 in order to adjust the brightness remotely.

Please note that the dimming and the heading telegram have to be input via the same serial interface.

It can be configured if the dimming should follow the DDC telegram or not (factory setting: "Dimming Group 0"). This can be done via the Configuration Tool AS. The following steps are required:

- Connect the Repeater Compass to the CAN Bus
- Select the CAN Bus interface as described in chapter 2.8
- Connect the Configuration Tool AS
- Start the "System Identification"
- Choose the respective device from the pull down menu
- "Request" the configuration data
- "Open" the configuration window
- Select "Dimming Group 0" if the Repeater Compass should not follow the DDC telegram (= local dimming)
- Select "Dimming Group 1" if the Repeater Compass should follow the DDC telegram (central dimming)
- Save and close the Configuration Tool AS
- Connect the Repeater Compass to NMEA
- Configure the Repeater Compass NMEA/course bus (SCI) interface



2.8.2.2 Central Dimming via CAN Bus

Central dimming values are only accepted from NautoSteer AS Steering Gear Control System. Please note that it is required to connect the Repeater Compass via the CAN Bus Distribution Unit AS (Drawing Number: 138-128) to the redundant CAN Bus of the Standard 22 System.

Please follow the following steps for configuration:

- Select the CAN Bus interface as described in chapter 2.8
- Use the Configuration Tool AS (Version 1.6.0967 or higher)
- Start the “System Identification”
- Choose the respective device from the pull-down menu
- “Request” the configuration data
- “Open” the configuration window
- Choose the “Dimming Group” (0=local dimming) and modify the dimming curve if required

2.10 Fault operation



Please note:

All possible error indications, their causes and required measures are described in detail in section 4.2.2.

Effect: The heading indication on the digital display does not correspond to the heading of the ship.

Measures: Check connections, or call RAYTHEON Anschütz service.

Indications	Comments, notes
<p style="text-align: center;">○ (red)</p> <div style="display: flex; align-items: center; justify-content: center;"> <div style="border: 1px solid black; padding: 2px; margin-right: 10px;"> <p style="font-family: monospace; font-size: 1.2em;">- - - . -</p> </div> <div style="margin-right: 10px;">flashing</div> </div> <p style="text-align: center;">or:</p> <div style="display: flex; align-items: center; justify-content: center;"> <div style="border: 1px solid black; padding: 2px; margin-right: 10px;"> <p style="font-family: monospace; font-size: 1.2em;">[on</p> </div> <div style="margin-right: 10px;">flashing</div> </div>	<p>- LED lights up red continuously and <u>cannot</u> be dimmed to zero.</p> <p>Types of errors:</p> <p>“- - - . -” :</p> <ul style="list-style-type: none"> - Serial interface defective or - transmitted telegram invalid or - input signal disturbed or - configuration not according to the current telegrams <p>or</p> <p style="padding-left: 20px;">operation mode (operator fault)</p> <p>“Con” :</p> <ul style="list-style-type: none"> - No data transmitted or - Serial interface is not connected. - Magnetic heading sensor defect - Satellite heading sensor defect

2.11 Switching off the Repeater Compass

The Repeater Compass is switched off by switching off the supply voltage.

**Repeater Compass
133-560**

Intentionally left blank

3 Installation of the Repeater Compass

3.1 General



Warning!

Before establishing the cable connection the supply voltage must be switched off. Ensure that the supply voltage cannot be switched on during installation.



Please note:

The Repeater Compass should be connected at the cable ends without opening of the housing.



Caution!

Do not open the Repeater Compass when mounting it or during the normal operation.



Caution!

Installation, maintenance and configuration must be carried out only by properly trained and qualified staff with a good knowledge of equipment safety regulations.

3.1.1 Mounting of the Repeater Compass

The series of repeaters type “133-560 NG...” are assembled in different enclosures for:

- desk-flush mounting
- bulkhead mounting
- wall mounting

For mounting the Repeater Compass pay attention to the following:

- The cards, the operating and indicating elements should be well addressable.
- Protect the cards against solar radiation.
- Ensure the type of enclosure.
- The Repeater Compass should not be installed in oil-containing ambient air.
- For dimensions and drilling see dimensional drawings in the annex.
- Ensure enough mounting space for the cable entry.
- The Repeater Compass should be mounted seaworthy.

3.1.2 Electrical installation of the Repeater Compass

The supply cable of the Repeater Compass that has to be connected to the ships mains and the heading interface is already connected to the terminal strip inside the repeater. It is fixed in the cable entry of the repeaters casing.

Connect the voltage supply cable and the data cable (NMEA, Course bus or CAN Bus) interface as shown in Figure 3-1:

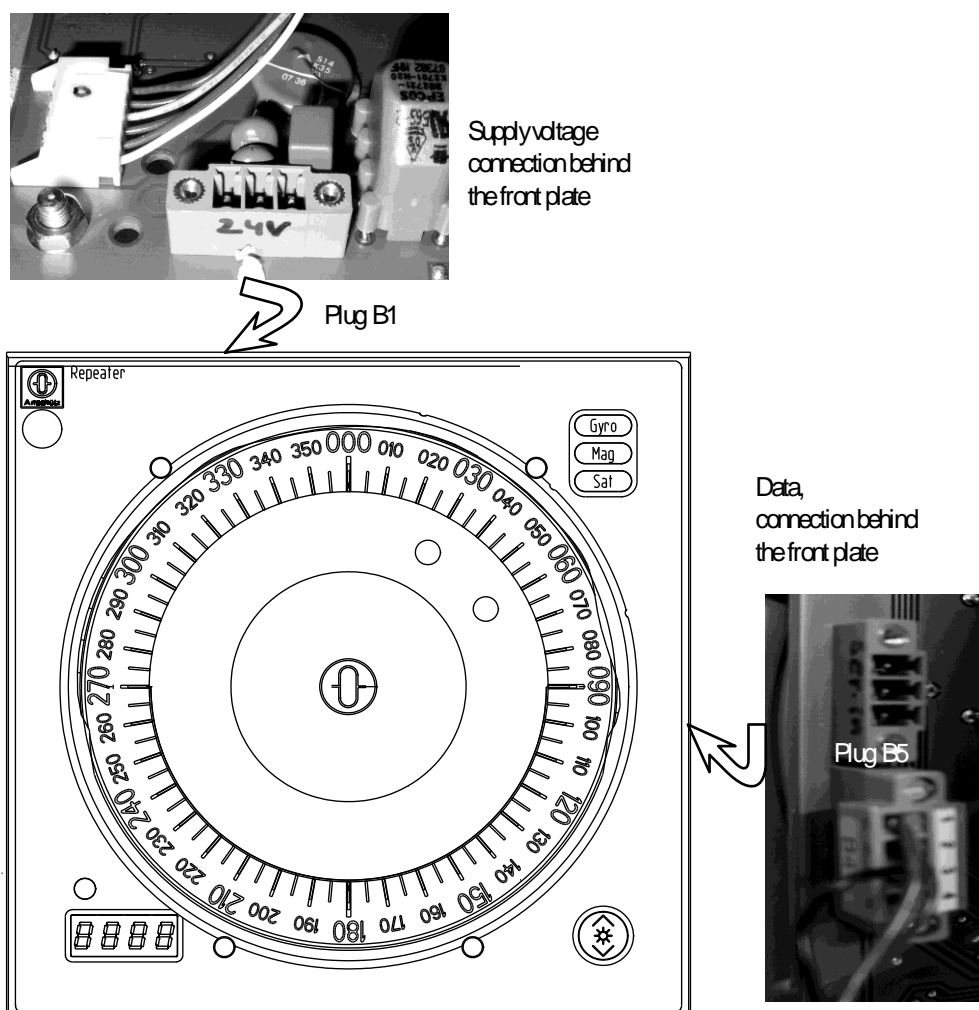

Figure 3-1 Cable connection of the Repeater Compass

See also appended Connection diagram 133-560.HP027.

Repeater Compass 133-560

Table 3-1 Cable connection of the Repeater Compass

Plug/terminal	Designation
B1/1	+ supply voltage
B1/2	- supply voltage
B1/3	GND supply voltage
B5/1	CAN High or Rx+*
B5/2	CAN LOW or Rx-*
B5/3	CAN GND*

* CAN Bus is automatically terminated after selection/configuration as the serial interface.

3.2 First setting into operation

- Switch on the Repeater Compass as described in section 2.4.
- The Repeater Compass recognizes the course bus interface and adjusts to it automatically.
- For NMEA/CAN operation the Repeater Compass has to be configured.

4 Maintenance and shipboard repair

4.1 Maintenance

The Repeater Compass requires no special care and maintenance. The analogue indication (cards) has to be checked frequently. The indication has to correspond to the digital indication. If the indications differ, switch off the supply voltage and restart the Repeater Compass. If the indication is still false, the analog indication of the Repeater Compass has to be adjust again (refer to section 2.9).



Please note:
FLASHING A SOFTWARE
Used microcontroller type is MB 91F 464 A

4.2 Shipboard repair





4.2.1 General

A defective Repeater Compass has to be exchanged completely. Single parts will not be exchanged.

Repeater Compass 133-560

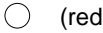
4.2.2 Measures in case of alarms on the Repeater Compass

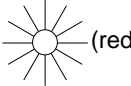

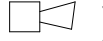
The possible alarms of the Repeater Compass are indicated as error codes on the digital display of the Repeater Compass.

Error code	Error type	Possible cause	Measures
No or false indication.	Fault of the electronic.	PCB of the Repeater Compass is disturbed or defective.	<ul style="list-style-type: none"> - Switching off and on the power supply (Restart) - if necessary exchange Repeater Compass
 (red)  flashing	Serial interface defective or transmitted telegram invalid.	- Heading sensor transmits no or invalid data.	- Check the heading source sensor
		- False configuration of the Repeater Compass	<ul style="list-style-type: none"> - Configure Repeater Compass - Restart Repeater
		- Repeater Compass defective	- Exchange Repeater Compass
 (red)  flashing  (Course bus and "G_AL")	No data transmitted.	- Cable defective	<ul style="list-style-type: none"> - Confirm alarm by operating the key - LED flashes red - Check cable connections
		- False configuration	<ul style="list-style-type: none"> - Confirm alarm by operating the key - LED flashes red - Configure Repeater Compass again - Restart repeater
		- System compass (Gyro/Magnetic/Satellite) defective	<ul style="list-style-type: none"> - Confirm alarm by operating the key - LED flashes red - Check system compass
		- Serial interface disconnected	<ul style="list-style-type: none"> - Confirm alarm by operating the key - LED flashes red - Connect serial interface

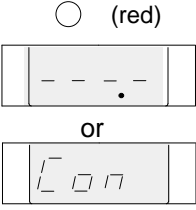

Error code	Error type	Possible cause	Measures
Analogue indication does not correspond to the digital indication	De-synchronisation of analogue and digital indication.	Stepping fault of one stepping motor.	- Correction of the analogue indications (refer to section 2.9)
Heading indication correct, cards do not move	Shaft of the analogue indication is fixed.	- Stepping motor defective or - electronic defective	Exchange the Repeater Compass.
Cards and digital display changing between two heading values	Configuration fault	- Operating fault	- Check and configure the interface telegrams and the operating modes.
Cards do not move to the lubber line or keep moving.	Disturbed calibration		- Restart Repeater Compass (Off-On, several times if needed). - Exchange Repeater Compass if necessary.
Heading indication frozen/constant	External error	- Disturbed operating program	- Restart Repeater Compass (Off-On, several times if needed).
One of the cards turns constantly	Internal error	Magnetic contact is not detected	- Restart Repeater Compass (Off-On) - Exchange Repeater Compass if necessary.
Analogue adjustment is not successful	Internal error	Zone of possible adjustment is exceeded	- Restart Repeater Compass (Off-On) - Exchange Repeater Compass if necessary.
3-line display switches between two heading sensors	Faulty configuration	Check configuration	- Change configuration - Restart Repeater Compass (Off-On) - Exchange Repeater Compass if necessary.
2 different heading data are displayed alternating	Faulty configuration External fault	Check configuration Data transmission faulty	- Change configuration - Restart Repeater Compass (Off-On) - Exchange Repeater Compass if necessary. - Check heading sources

Repeater Compass 133-560

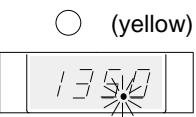
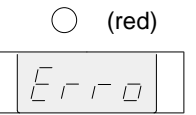
Error code	Error type	Possible cause	Measures
 <p style="text-align: center;">○ (red)</p> <p style="text-align: center;">External error Configuration error</p>	<p>Adjustments at the Repeater and settings at the respective source (Distribution Unit or Compass) do not match.</p>	<ul style="list-style-type: none"> - Check configuration/ settings and adjustments at connected Distribution Unit or compass. Especially NMEA sentences THS and HDT. 	
Course bus operation only:			
 <p style="text-align: center;">○ (yellow)</p> <p style="text-align: center;">Fault of the system compass. Causes restart of the settling phase of the gyro compass.</p>	<ul style="list-style-type: none"> - Fault of the system compass; - Supply voltage is switched off automatically. 	<ul style="list-style-type: none"> - Wait until end of the settling phase approx. 4 h. - Switch on the GPS compass if necessary. 	
 <p style="text-align: center;">○ (yellow)</p> <p style="text-align: center;">Message from system compass</p>	<ul style="list-style-type: none"> - System compass detects limiting values. 	<ul style="list-style-type: none"> - Check system compass. 	
<p>Incomplete 7 segment display</p>	<p>Display LED defective.</p>	<ul style="list-style-type: none"> - LED defective. 	<ul style="list-style-type: none"> - Exchange Repeater Compass.
 <p style="text-align: center;">○ (red)</p> <p style="text-align: center;">Error message from system compass.</p>	<ul style="list-style-type: none"> - System compass detects limiting values. 	<ul style="list-style-type: none"> - Check system compass. - Check Distribution Unit 	



5

Disposal

The DC/DC Converter or components of it can be disposed according to the respective national regulations for electronic waste without harmful material (according to 2002/96EC WEEE - disposal for Waste Electrical and Electronic Equipment).

**Repeater Compass
133-560**

Intentionally left blank

Tochterkompass
Repeater Compass
Type 133-560.NG011, NG013, NG014, NG015



Ersatzteilkatalog
SPARE PARTS
CATALOGUE

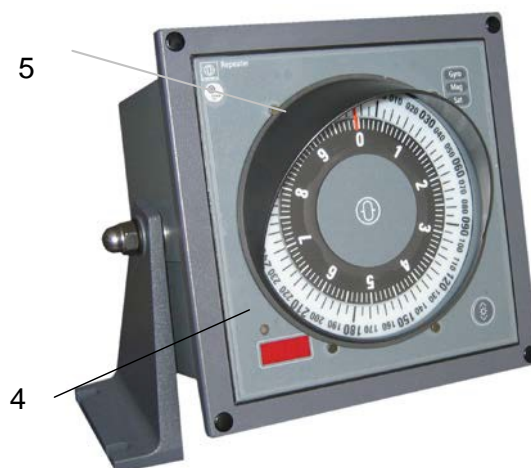
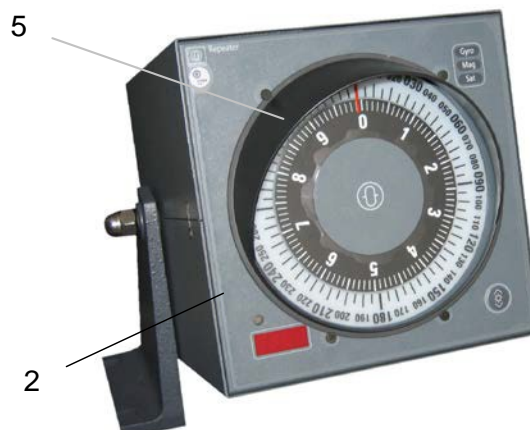

Pos.	Benennung	Designation	Zeichnungs-Nr. Part-No.	Lager-Nr. Stock-No.	Stck. Qty.	Herst.-Code MFRC	Versorgungs-Nr. NSN
1	Tochterkompass, basaltgrau, RAL 7012 IP 23	Repeater Compass, basalt grey, RAL 7012 IP 23	133-560.NG011	4003292 No longer available		D2865	6605-12-386-8157
			Replacement is 133-560.NG011 E01	Replacement is 4005628			tbd
2	Tochterkompass, basaltgrau, RAL 7012 IP 44	Repeater Compass, basalt grey, RAL 7012 IP 44	133-560.NG013	4003322		D2865	
3	Tochterkompass, basaltgrau, RAL 7012 IP 44	Repeater Compass, basalt grey, RAL 7012 IP 44	133-560.NG014	4003338		D2865	
4	Tochterkompass, basaltgrau, RAL 7012 IP 56	Repeater Compass, basalt grey, RAL 7012 IP 56	133-560.NG015	4003350		D2865	
5	Blende	Antiglare Screen	133-555.00-001	1504798		D2865	6695-01-484-8506

Andere Farben auf Anfrage
Other Colors on request

All depicted items which are not mentioned in the text are not applicable for this unit. Since further development may necessitate making modifications to existing equipment, its conformity with the relevant illustrations and drawings is not always ensured. Raytheon Anschütz will be under no liability whatever that may arise from any such differences.

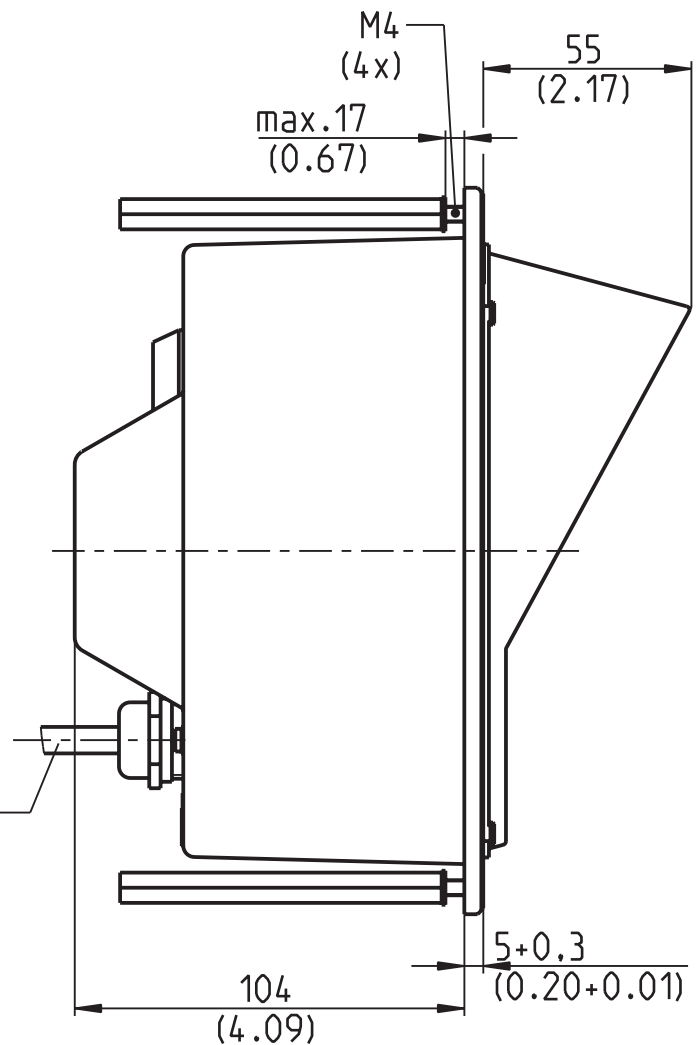
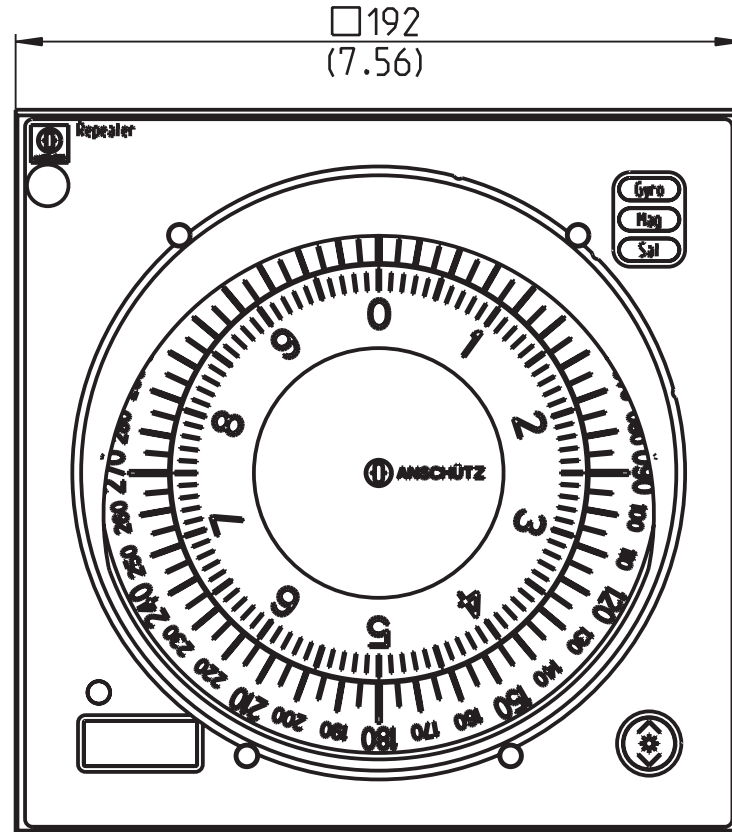

LENGTH APPROX.: CA. 3m

DILLING SCHEME

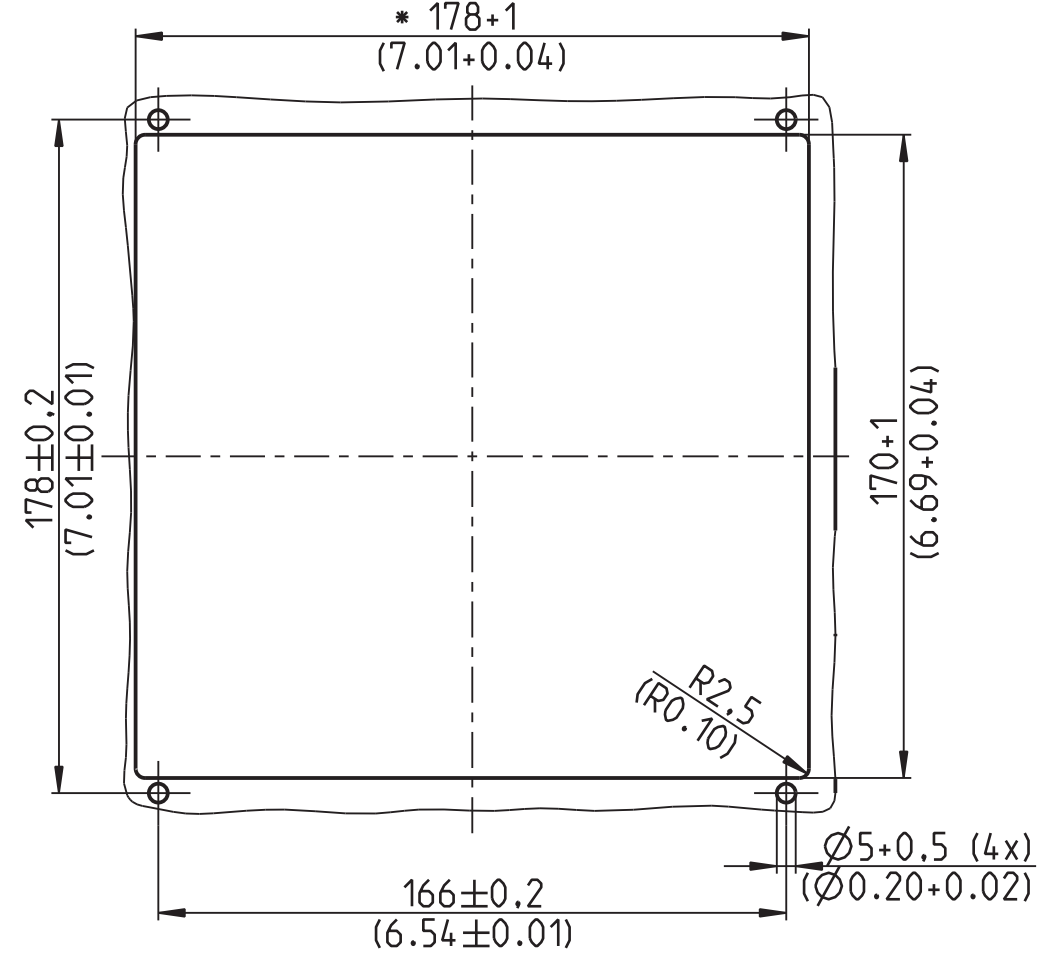

* DIMENSION WIDTH ACCORDING TO RAYTHEON ANSCHÜTZ INTERNAL NORMATIVE REFERENCES. THIS STEERING REPEATER FITS ALSO IN CUTOUTS WITH 172mm (6.77) WIDTH.

TYPE OF ENCLOSURE: EN 60529 IP23/IP56 FRONT-SIDED
EVENNESS OF MOUNTINGSURFACE < 0.1mm

DIMENSIONS WITHOUT TOLERANCES ARE MAXIMUM DIMENSIONS

DISTANCE FROM MAGNETIC COMPASS			CAD: Pro/E	ID.NO.: 5021453
STANDARD TYPE: 0.55 m			STEERING TYPE: 0.35 m	
			SCALE: -	WEIGHT: ca. 1.7 Kg
		mm (INCH)	DRAWING TITLE:	
		DATE	REPEATER COMPASS	
		NAME	DIMENSIONAL DRAWING	
		DR. 21.07.08 Zm	DRAWING NO.:	
		APPR. 22.07.08 Bey	133-560.HP025	
		CHK. 04.09.08 Lut	SH. 1	
		RELEASE: 23.09.08	OF 1	
		Raytheon		
		Anschütz		
A	1000568	19.08.10	Zm	
REV.	REVISIONS	DATE	NAME	

For this technical document all rights reserved.

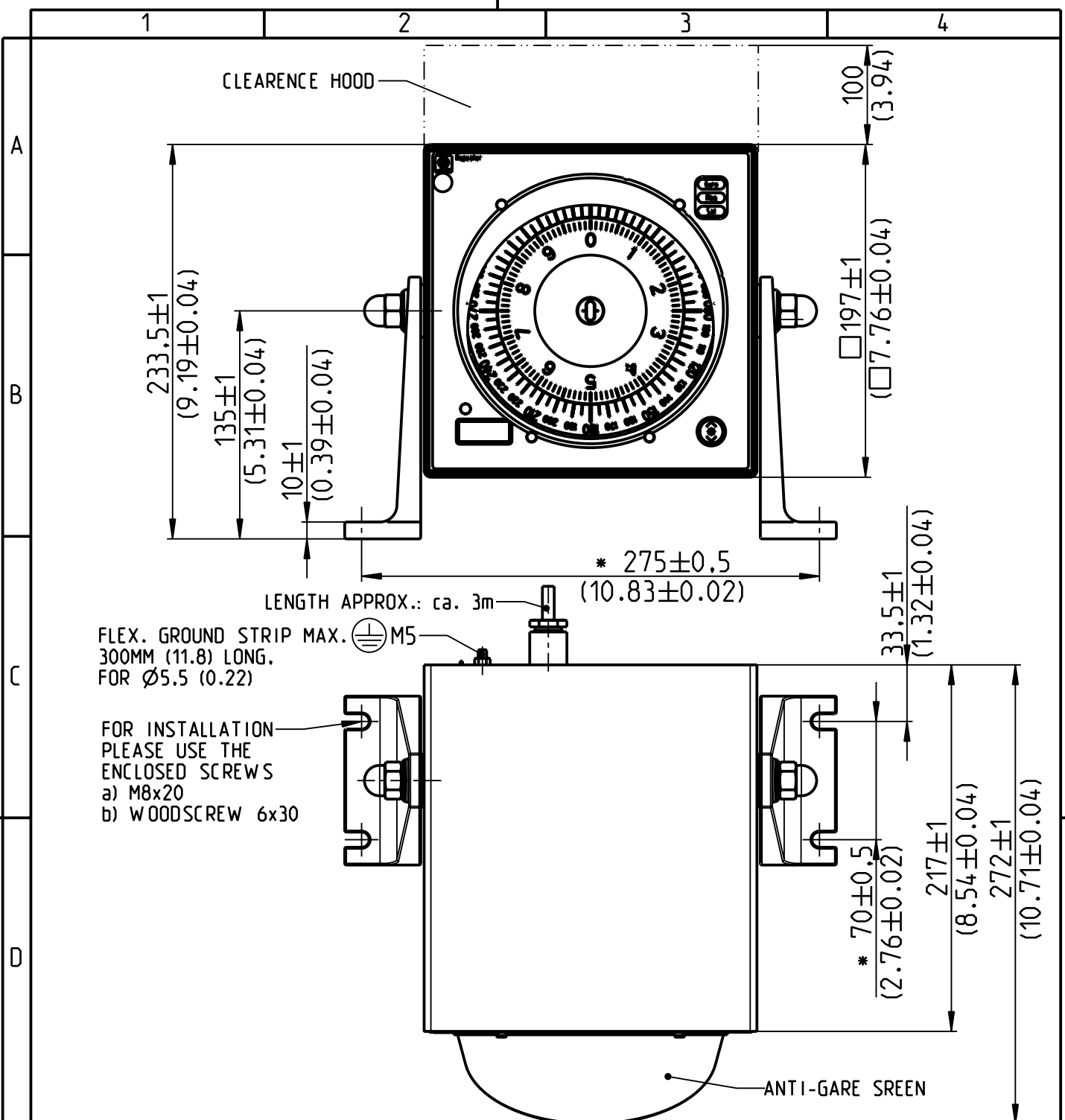



FLEX. GROUND STRIP MAX. \oplus M5
300MM (11.8) LONG.
FOR $\varnothing 5.5$ (0.22)

FOR INSTALLATION
PLEASE USE THE
ENCLOSED SCREWS
a) M8x20
b) WOODSCREW 6x30

* REFERING TO DRILLING SCHEME ON BOARD

TYPE OF ENCLOSURE AFTER INSTALLATION OF DEVICES: EN 60529 IP44
DIMENSIONS WITHOUT TOLERANCES ARE MAXIMUM DIMENSIONS

DISTANCE FROM MAGNETIC COMPASS		CAD: Pro/E	ID.NO.: 5021456
STANDARD TYPE: 0.55 m		SCALE: -	
STEERING TYPE: 0.35 m		WEIGHT: ca.4.5 Kg	
		DRAWING TITLE:	
mm (INCH)		Repeater with Casing	
DATE NAME		DIMENSIONAL DRAWING	
DR. 21.07.08 Zm		DRAWING NO.:	
APPR. 22.07.08 Bey		133-560.HP028	
CHK. 04.09.08 Ludzuweit		SH. 1	
RELEASE: 23.09.08		OF 1	
			
REV.	REVISIONS	DATE	NAME

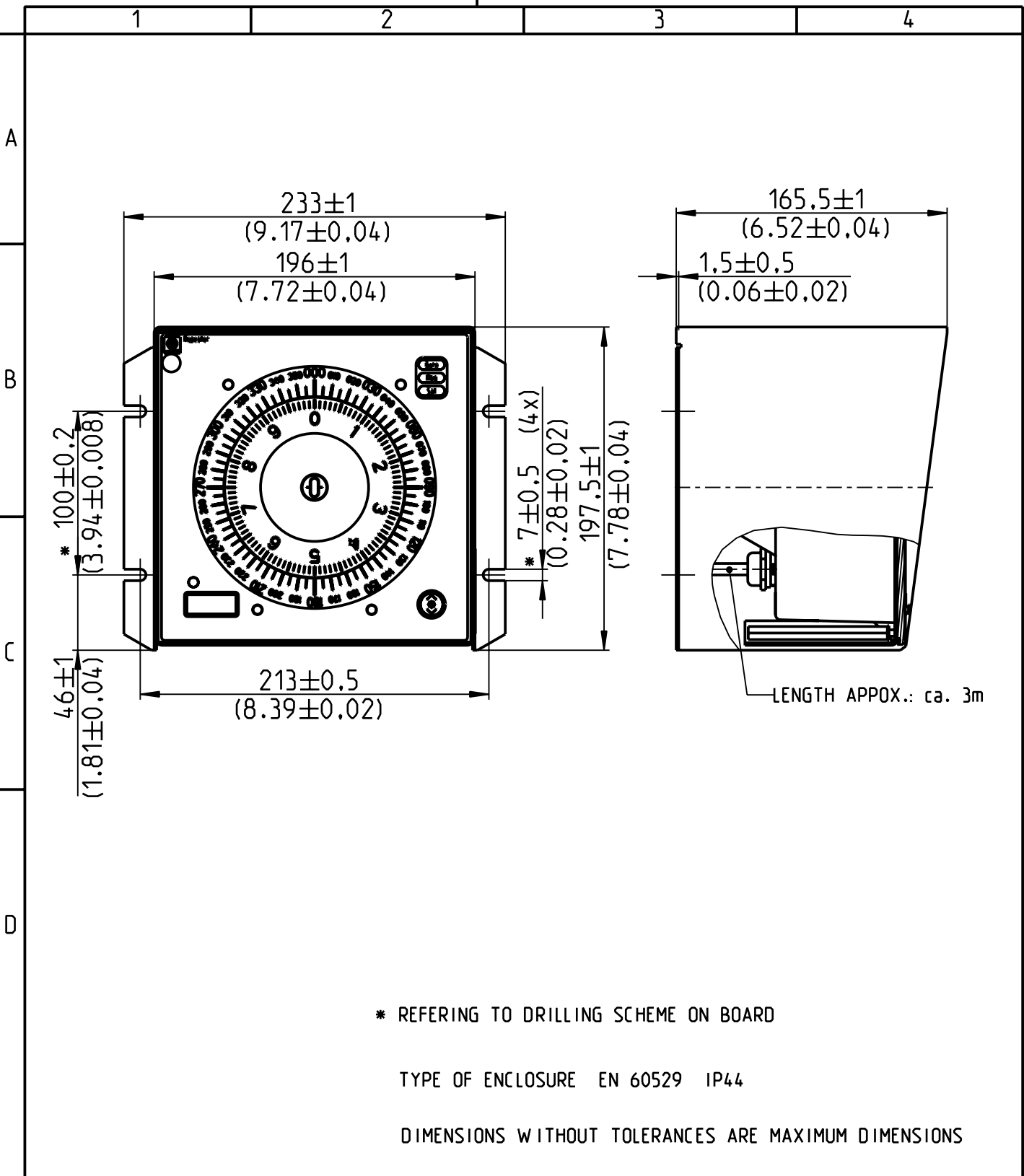

* REFERING TO DRILLING SCHEME ON BOARD

TYPE OF ENCLOSURE EN 60529 IP44

DIMENSIONS WITHOUT TOLERANCES ARE MAXIMUM DIMENSIONS

For this technical document all rights reserved.

DISTANCE FROM MAGNETIC COMPASS				CAD: Pro/E		ID.NO.: 5021458	
STANDARD TYPE: 0.55 m				STEERING TYPE: 0.35 m			
				mm (INCH)		SCALE: -	
						WEIGHT: ca. 3.5 Kg	
				DRAWING TITLE:			
				<h2>Repeater with Casing</h2> <h3>DIMENSIONAL DRAWING</h3>			
				DRAWING NO.:		SH. 1	
				133-560.HP030		OF 1	
REV.	REVISIONS	DATE	NAME				

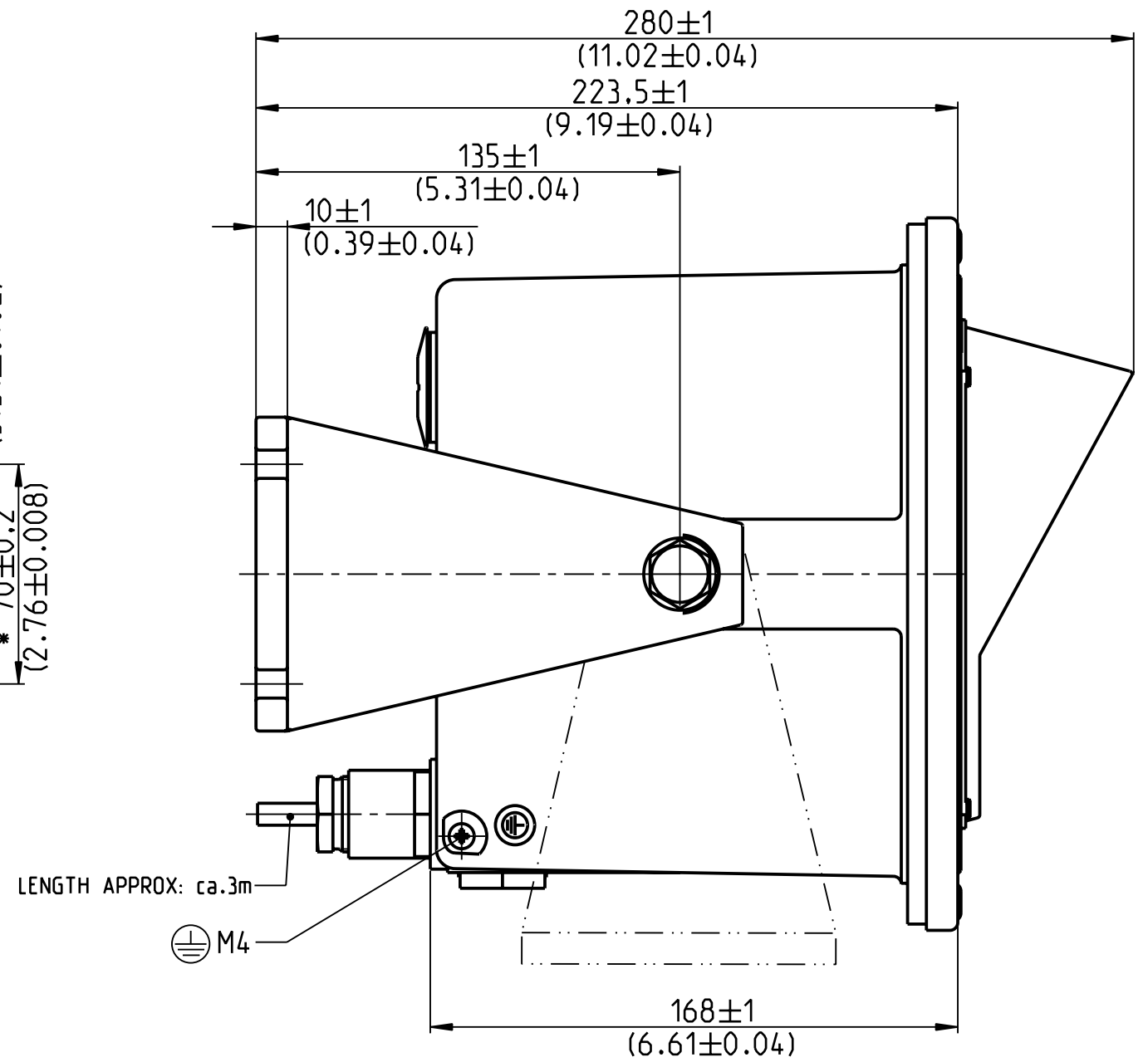
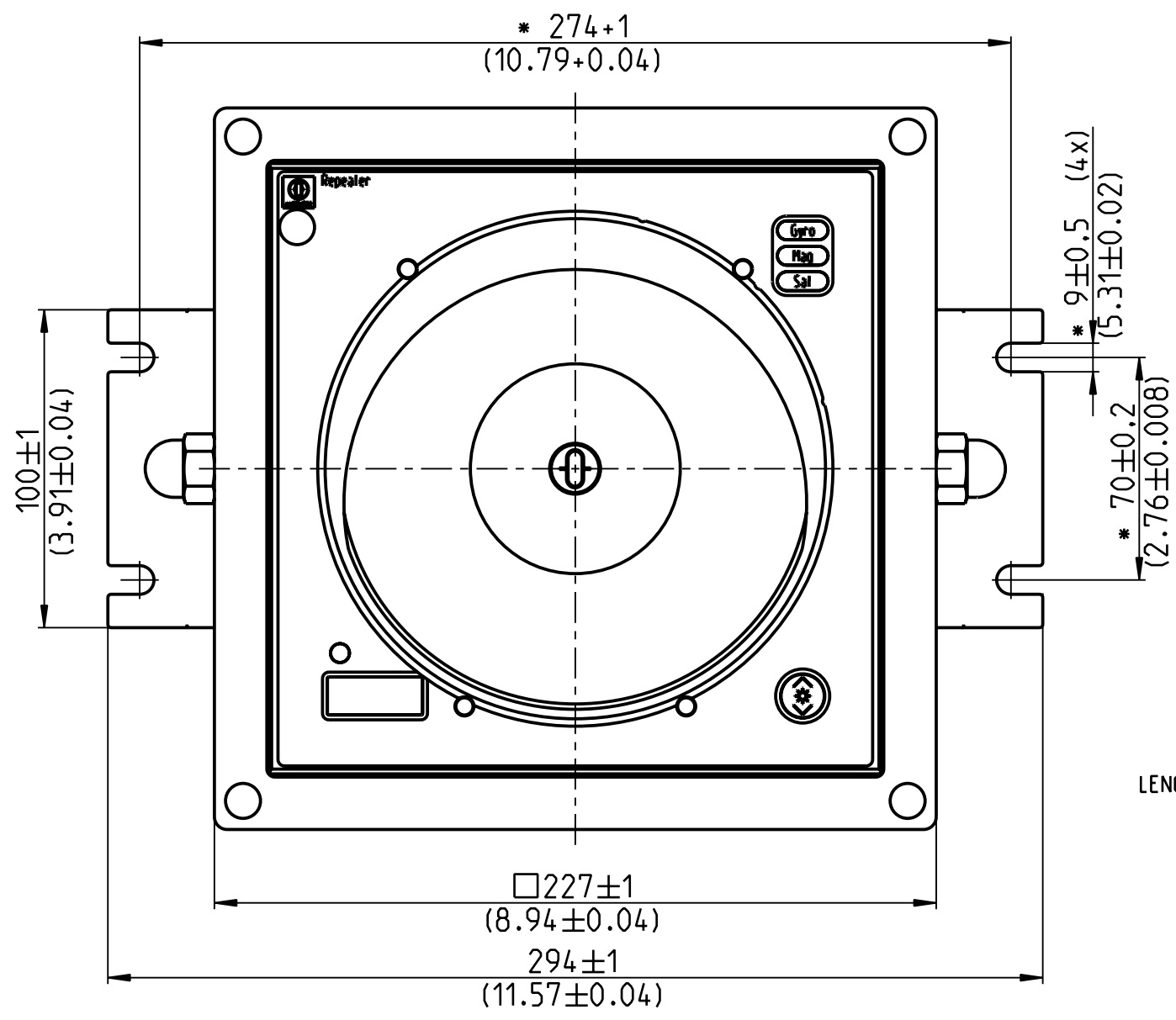

* REFERRING TO DRILLING SCHEME ON BOARD
 TYPE OF ENCLOSURE: EN 60529 IP56
 DIMENSIONS WITHOUT TOLERANCES ARE MAXIMUM DIMENSIONS

DISTANCE FROM MAGNETIC COMPASS		CAD: Pro/E	ID.NO.: 5021460																				
STANDARD TYPE: 0.55 m		STEERING TYPE: 0.35 m																					
		SCALE: -	WEIGHT: ca.4.5 Kg																				
		DRAWING TITLE: Repeater with Casing DIMENSIONAL DRAWING																					
<table border="1"> <thead> <tr> <th>REV.</th> <th>REVISIONS</th> <th>DATE</th> <th>NAME</th> </tr> </thead> <tbody> <tr> <td>DR.</td> <td></td> <td>18.07.08</td> <td>Zm</td> </tr> <tr> <td>APPR.</td> <td></td> <td>22.07.08</td> <td>Bey</td> </tr> <tr> <td>CHK.</td> <td></td> <td>04.09.08</td> <td>Ludzuweit</td> </tr> <tr> <td>RELEASE:</td> <td></td> <td>23.09.08</td> <td></td> </tr> </tbody> </table>		REV.	REVISIONS	DATE	NAME	DR.		18.07.08	Zm	APPR.		22.07.08	Bey	CHK.		04.09.08	Ludzuweit	RELEASE:		23.09.08		DRAWING NO.: 133-560.HP032	
REV.	REVISIONS	DATE	NAME																				
DR.		18.07.08	Zm																				
APPR.		22.07.08	Bey																				
CHK.		04.09.08	Ludzuweit																				
RELEASE:		23.09.08																					
		SH. 1 OF 1																					

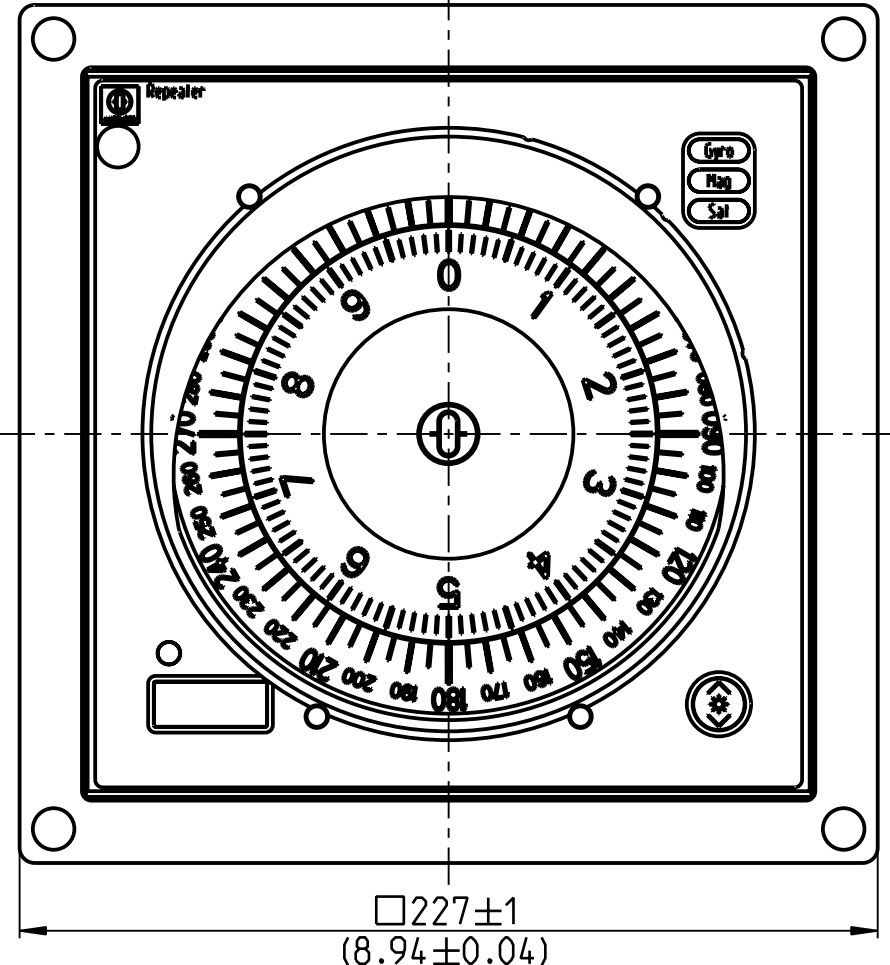

DRILLING SCHEME

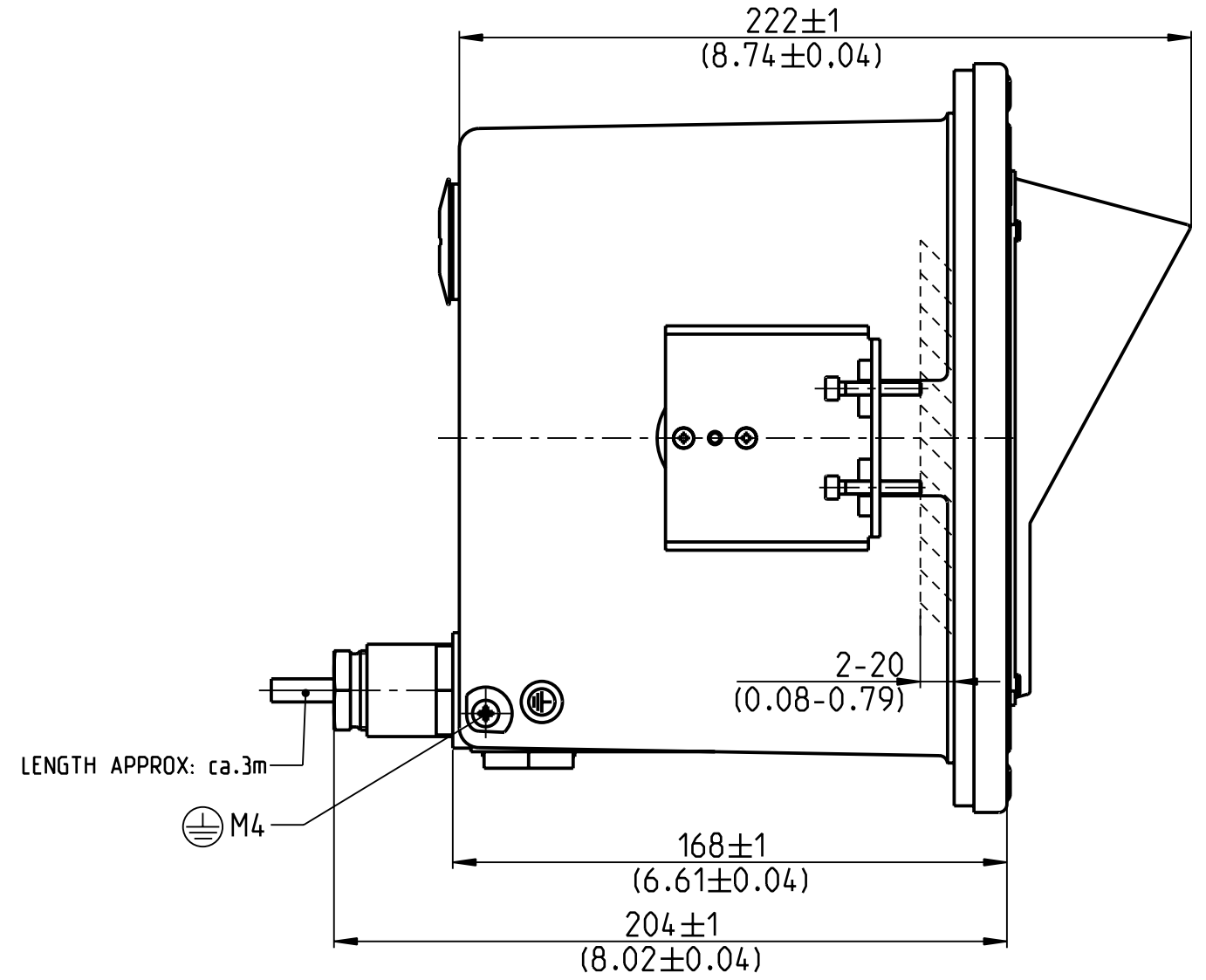
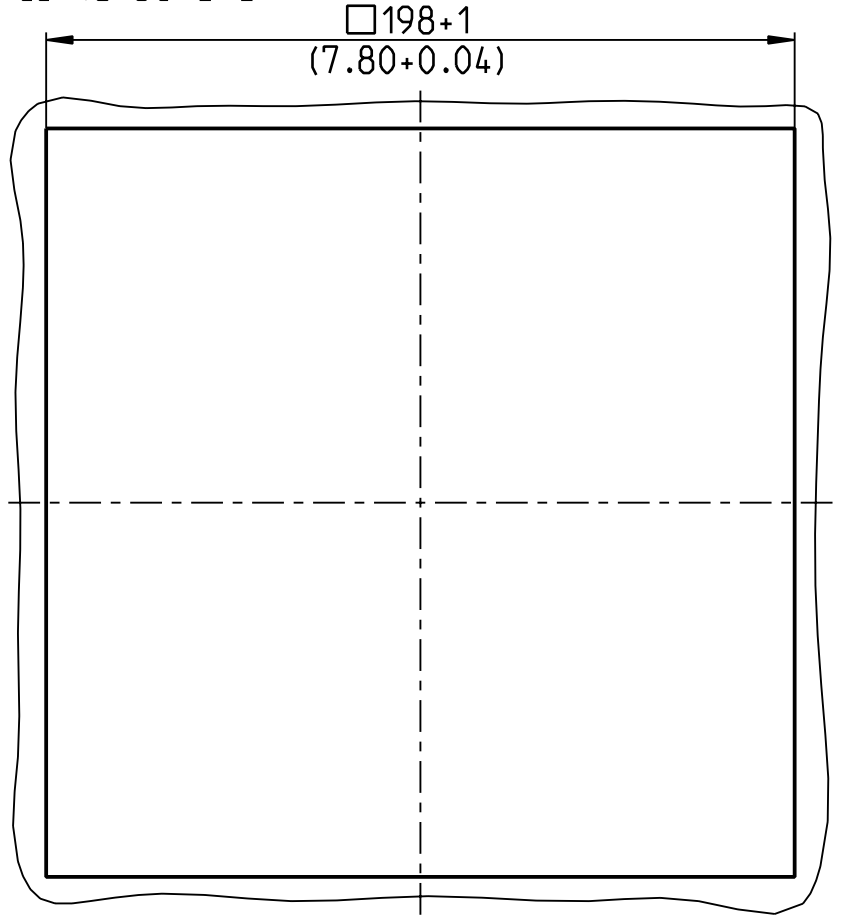

* REFERING TO DRILLING SCHEME ON BOARD
 TYPE OF ENCLOSURE: EN 60529 IP56
 DIMENSIONS WITHOUT TOLERANCES ARE MAXIMUM DIMENSIONS

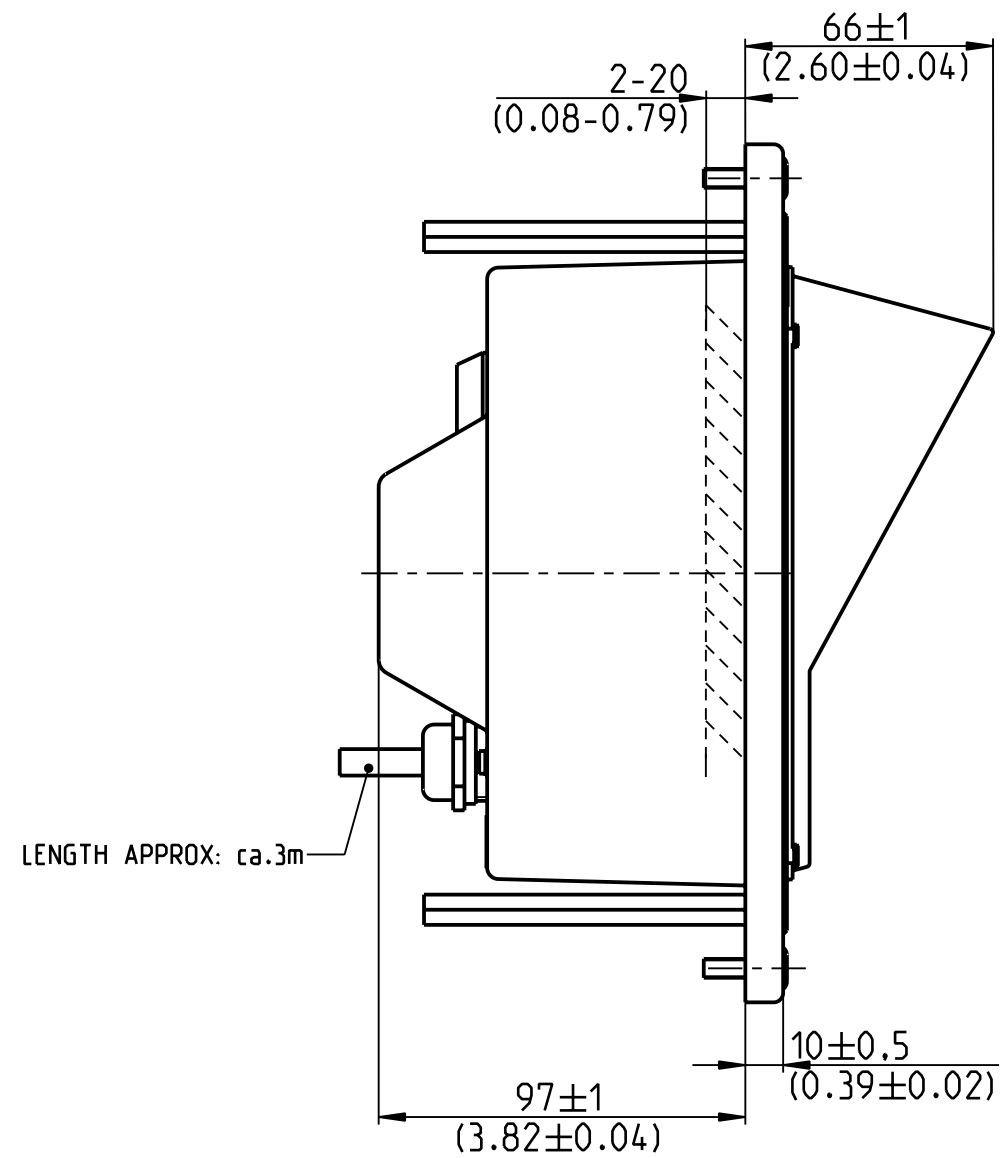
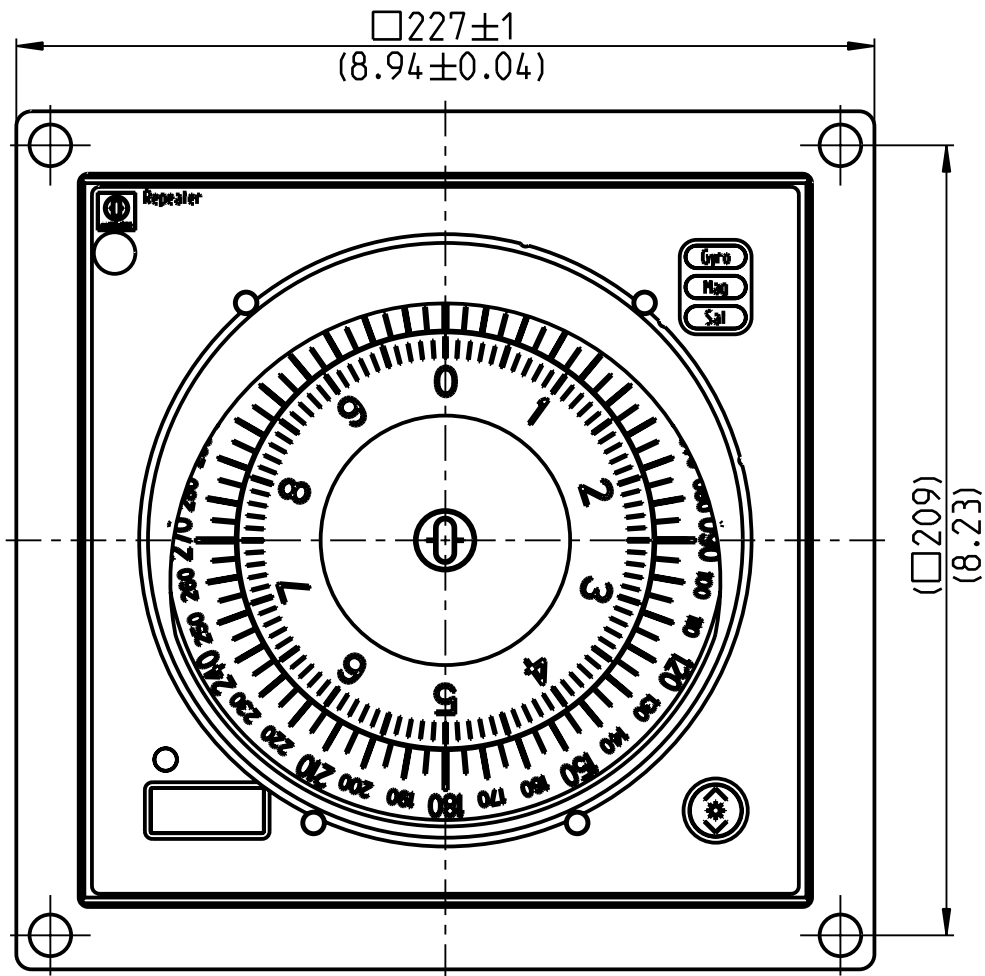

DISTANCE FROM MAGNETIC COMPASS		CAD: Pro/E	ID.NO.: 5021462
STANDARD TYPE: 0.55 m		STEERING TYPE: 0.35 m	
		SCALE: -	
		WEIGHT: ca.4.5 Kg	
		DRAWING TITLE:	
		Repeater with Casing	
		DIMENSIONAL DRAWING	
		DRAWING NO.:	
		133-560.HP034	
REV.	REVISIONS	DATE	NAME
SH. 1	OF 1		

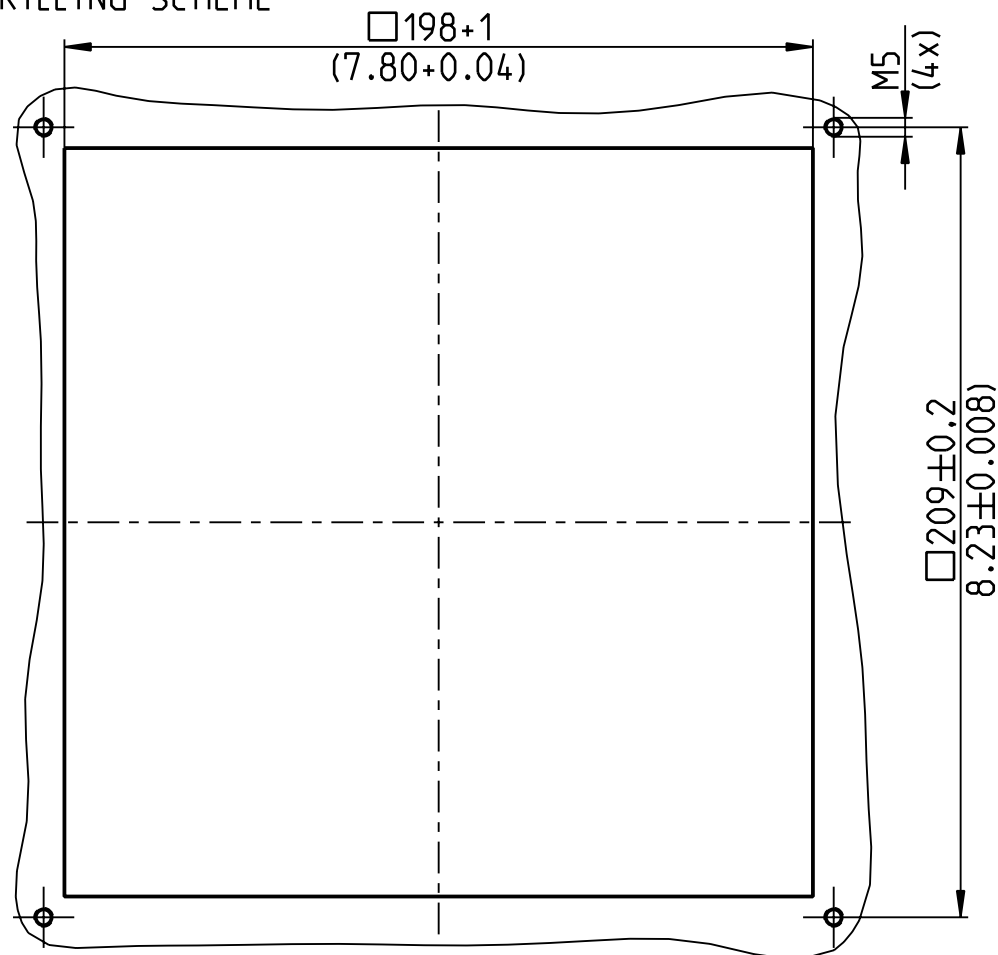

DRILLING SCHEME

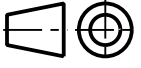

* REFERRING TO DRILLING SCHEME ON BOARD
 TYPE OF ENCLOSURE: EN 60529 IP56
 DIMENSIONS WITHOUT TOLERANCES ARE MAXIMUM DIMENSIONS

DISTANCE FROM MAGNETIC COMPASS		CAD: Pro/E	ID.NO.: 5021464
STANDARD TYPE: 0.55 m		STEERING TYPE: 0.35 m	
		mm	
		(INCH)	
REV.	REVISIONS	DATE	NAME
		DR. 18.07.08	Zm
		APPR. 22.07.08	Bey
		CHK. 04.09.08	Ludzuweit
		RELEASE: 23.09.08	
			
DRAWING TITLE:		DRAWING NO.:	
Repeater with Mounting Frame		133-560.HP036	
DIMENSIONAL DRAWING		SH. 1	OF 1

NMEA / COURSE BUS / CAN BUS

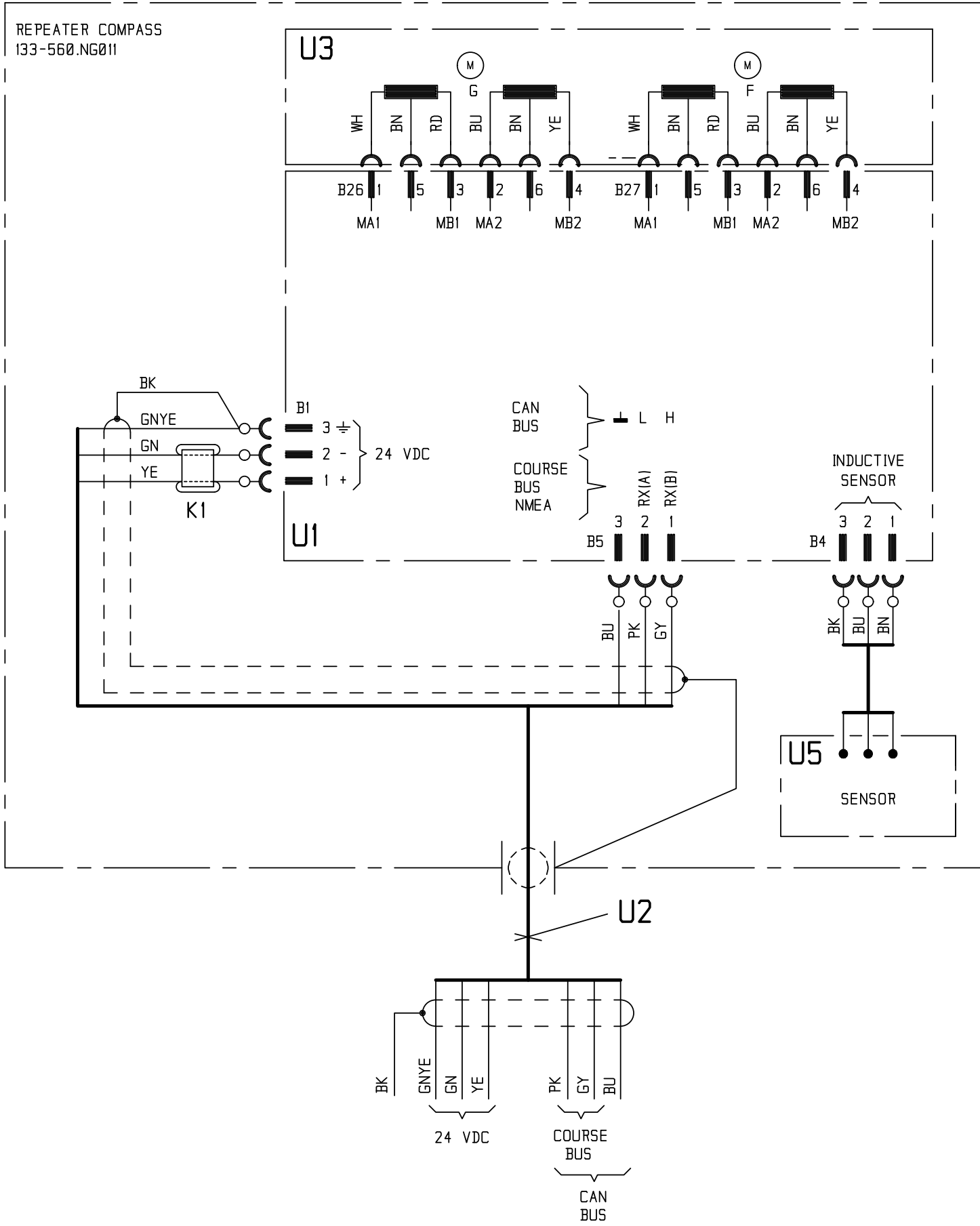

DIN CODE	BENENNUNG DESCRIPTION	TYP/ZEICHN.-NR. TYPE/DRAWING NO.	POS NO.	AUS STÜCKLISTE FROM PARTS LIST
K1	FERRIT CORE	TR 16-8-13	63	133-560.NG011
U1	STEERING REPEATER COMPASS PCB, PROG.	133-560.110	10	133-560.NG011
	STEERING REPEATER COMPASS PCB	NB06-331.	1	133-560.110
B26	PLUG	S 6B-XH-A-1	B26	NB06-331.
B27	PLUG	S 6B-XH-A-1	B27	NB06-331.
U2	CABLE	NB60-306.	16	133-560.NG011
U3	STEPPING MOTOR	133-560.09	2	133-560.NG011
U5	SENSOR WITH CABLE	133-407.09	12	133-560.NG011

CAD		B 4768 D	ID.NR.	5021455
MASSSTAB		1:1		
WERKSTOFF				
BENENNUNG		TOCHTERKOMPASS / REPEATER COMPASS		
ANSCHLUSSPLAN / CONNECTION DIAGRAM		ZEICHNUNGSNUMMER		
		133-560.HP027		
VER.		ANDERUNG	AUSGABEDATUM	NAME
03	50000038781	21.07.14	STE	
B	0900170	13.03.09	RIE	
A	0801012	18.12.08	RIE	
		28.08.08	RIE	

ALLGEMEINTOLERANZ
ISO 2768 - mK

ERSTELLT DURCH
RIENITZ

GENEHMIGT VON
KÜHL