

7. CERTIFICATION

The following UL certification information is imprinted on the sensor body.

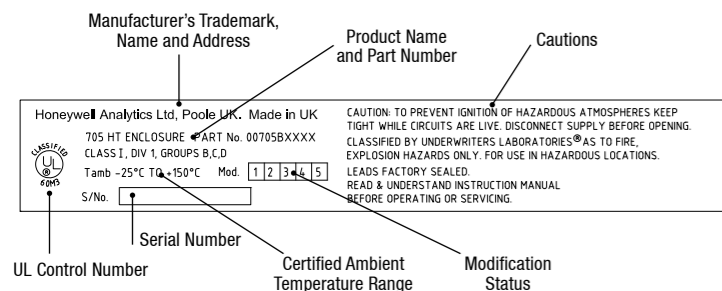

11

8. SPECIFICATIONS

Operating temperature range	-25°C to +150°C
Storage temperature range	-25°C to +150°C
Operating humidity range	20% to 90% RH continuous - non condensing 10% to 100% RH intermittent -non-condensing
Drive current	200mA +/- 2mA (from control equipment)
Power consumption	0.7W
Calibration flow rate	Recommended 1.5 l/min +/- 0.1 l/min
Response time	T60 - less than 6 sec. T90 - less than 10 sec.
Temperature coefficient of zero point	Approximately 0.05% LEL Methane per °C (maximum)
Line resistance	Refer to control system documentation
UL Certification	Class I, Div 1, Groups B, C, D Tamb -25°C to +150°C
Dimensions and weights	
Sensor	
Dimensions	78mm x 55mm (51mm or 47.2mm across flats)
Weight	200g
Collecting Cone	
Dimensions	87mm x 165mm dia.
Weight	175g

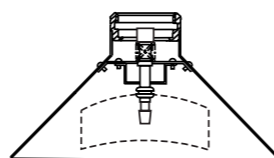

12

8. SPECIFICATIONS

Weather Protection Housing		
Dimensions	76.5mm x 50.8mm dia.	
Weight	52.4g	
Sample Flow Housing		
Dimensions	61mm x 45mm x 31mm	
Weight	110g	

13

9. ACCESSORIES AND SPARE PARTS

When ordering accessories and parts, always quote the complete part number. Where a component part number is not listed or known, state type, material, cable entry size and other relevant details.

Complete replacement 705 HT sensor (Part No: 00705-A-1735)

Identify the gas to be detected when ordering a complete replacement sensor.

Collecting Cone (Part No: 00780-A-0032)

Used for the detection of lighter than air gases. A filter must be fitted. A nozzle on the cone (6.5mm O.D.) permits gassing of the Sensor with the cone in position. Test gas is applied either direct to the nozzle or via a permanently connected pipe-line when the sensor is in an inaccessible location.

Weather Protection Housing (Part No: 00780-A-0076)

This accessory, fitted to a sensor installed in an exposed location, protects the sensor from driving rain from vertical to 30° below horizontal. When mounted close to the ground, it protects from heavy rain rebounding off the ground. It also reduces contamination from industrial waste and enables the application of test gas in high wind speeds without significant error.

Incorporated in the housing is a nozzle to facilitate gassing of the sensor with the housing in position, either by direct application to the nozzle or via a permanently connected pipeline. The nozzle is free to rotate within the housing to allow removal from the sensor without disconnecting a permanently connected pipeline, when changing the filter and cleaning the sensor.

Sample Flow Housing (Part No: 00780-A-0035)

This accessory allows sampling of a closed system by means of two pipes. The housing is fitted to the sensor accessory thread by a locking ring that enables the housing to be removed without disconnecting the pipeline. The filter is retained by the housing and interfaces with a gasket bonded to the housing (Part No: 00780-A-0048).

Stainless Steel Filter (Part No: 00780-F-0018)

Two layers of stainless steel mesh in the form of a disc with a rubber rim to provide mechanical protection of the sinter and exclude large dust particles.

14

Quick Start Guide



1. INTRODUCTION

The 705 High Temperature (HT) Combustible Gas Sensor is a gas detector that is UL certified for Class I, Division 1, Groups B, C and D for installation in a hazardous area.

It employs a catalytic pellistor sensor device which is used as part of a bridge measuring circuit. The sensor must be mounted on a suitably UL approved high-temperature junctionbox in the hazardous area and connected to control equipment situated in a non-hazardous area to form part of a combustible-gas detection system.

The sensor comprises an aluminium housing containing a pair of poison resistant detector elements, with a sintered stainless steel disc forming the face of the sensor. The sensor contains two elements which are heated by a supply derived from the associated control equipment. One element is sensitive to the presence of combustible gas, the element temperature increasing in response to catalytic oxidation of the gas. The resultant rise in resistance of the sensitive element, proportional to gas concentration, is processed by the associated control module.

The non-sensitive element compensates for effects of changes in ambient temperature. The sensor drive current is set to a value appropriate to the type of elements used.

The housing has a 51mm or 47.2mm AF body with a 3/4 NPT mounting thread at one end and an M36 accessory thread on the other end. The following accessories are available for use with the sensor (also see Accessories & Spare Parts):

- Collecting Cone
- Weather Protection Housing
- Sample Flow Housing
- Hydrophobic Barrier
- Gassing Point Assembly

When delivered a disposable plastic Filter Housing with protective disc for the sinter is fitted to the M36 accessory thread.

Note: The protective disc should not be removed until after the sensor is installed.

Refer to Installation for different Honeywell Analytics System 57 components to which the 705 Sensor can be connected and to the associated control system documentation for external wiring and connection information.

If information outside the scope of these instructions is required please contact Honeywell Analytics. The types of information notices used throughout this document are as follows:



WARNING

Indicates hazardous or unsafe practice which could result in severe injury or death to personnel.

Caution: Indicates hazardous or unsafe practice which could result in minor injury to personnel, or product or property damage.

Note: Provides useful/helpful/additional information.

1

2. SAFETY

WARNINGS

1. This apparatus is not suitable for use in oxygen enriched atmospheres (>21% V/V). Oxygen deficient atmospheres (<10% V/V) may suppress sensor output.
2. Refer to local or national regulations relative to installation at the site.
3. Operators should be fully aware of the action to be taken if the gas concentration exceeds the alarm level.
4. Atmospheres above 100% LEL may suppress the sensor reading.
5. The catalytic detector element is resistant to catalyst poisons, however, abnormally high concentrations of halogenated hydrocarbons, vapours of heavy metals or compounds, some silicone compounds and sulphur compounds may cause loss of sensitivity.

CAUTIONS

1. Do not modify or alter the sensor construction as essential safety requirements may be invalidated.
2. Install using suitably approved and certified high temperature junction box, connectors and glands.
3. Installation should consider not only the best placing for gas leakage related to potential leak points, gas characteristics and ventilation, but also where the potential of mechanical damage is minimized or avoided.
4. The sintered disc on the sensor assembly must be kept free from contaminants, e.g. oil and dirt.
5. The Code of Practice covering Selection, installation, use and maintenance of detectors for flammable gases and oxygen, IEC 60079-29-2, should be complied with at all times. Refer to the appropriate local/national regulations relative to the installation site.
7. Dispose of in accordance with local/national disposal regulations. Materials used - Stainless Steel.

2

Find out more

www.honeywellanalytics.com

Contact Honeywell Analytics:

Europe, Middle East, Africa, India

Life Safety Distribution AG
Javastrasse 2
8604 Hegnau
Switzerland
Tel: +41 (0)44 943 4300
Fax: +41 (0)44 943 4398
India Tel: +91 124 4752700
gasdetection@honeywell.com

Americas

Honeywell Analytics Inc.
405 Barclay Blvd.
Lincolnshire, IL 60069
USA
Tel: +1 847 955 8200
Toll free: +1 800 538 0363
Fax: +1 847 955 8210
detectgas@honeywell.com

Asia Pacific

Honeywell Analytics Asia Pacific
#701 Kolon Science Valley (1)
43 Digital-Ro 34-Gil, Guro-Gu
Seoul 152-729
Korea
Tel: +82 (0)2 6909 0300
Fax: +82 (0)2 2025 0328
analytics.ap@honeywell.com

Technical Services

EMEA: HAexpert@honeywell.com
US: ha.us.service@honeywell.com
AP: ha.ap.service@honeywell.com

www.honeywell.com



We Save Lives



Please Note:

While every effort has been made to ensure accuracy in this publication, no responsibility can be accepted for errors or omissions. Data may change, as well as legislation, and you are strongly advised to obtain copies of the most recently issued regulations, standards, and guidelines. This publication is not intended to form the basis of a contract.

Issue 2 09/2013
H_MAN0625_EMEA1
00705M5010_ECO A04169
© 2013 Honeywell Analytics

Type 705 High Temperature Combustible Gas Sensor

3. INSTALLATION

The 705 HT sensor must be fitted into a suitable UL approved high temperature junction box fitted with an approved cable gland for external wiring. The sensor requires a 200mA current supply, nominal 3V, derived from a suitable control card.

Only a qualified installation engineer should install the sensor.

Install the sensor in a location free from direct heat sources and fit it so that it either points downwards or horizontally. It is not recommended that the sensor points upwards.

1. Isolate all associated power supplies and ensure that they remain OFF during the installation procedure. Ensure a gas free atmosphere.

2. Install a suitably approved UL high temperature junction box.

See the manufacturer's instructions. The box provides a mounting point for the sensor.

3. Remove the junction box lid.

4. Fit the 705 HT sensor to the junction box.

Ensure that the junction box thread and the sensor thread are compatible. The mounting threads should be coated with an approved anti-seize compound, such as a light petroleum grease.

Push the sensor wires through the cable entry in the junction box and screw the sensor body firmly home into the entry. To comply with certification requirements, a minimum of five threads must be engaged.

5. Connect the sensor wiring to the junction box terminal strip.

See the subsequent wiring diagram. Use multicore cable, three wire minimum, of conductor size 2.5mm² (14AWG) max.

6. Fit a suitable gland/conduit to the box, secure the control system cable and connect the cable wiring to the terminal strip.

7. Refit the junction box lid.

8. Unscrew the filter housing from the sensor body and remove the filter from the filter housing.

Discard the filter housing with protective disc. The filter housing material cannot withstand high temperatures. Keep the filter.

3

4. CALIBRATION

Sensors should be calibrated at concentrations representative of those to be measured. It is always recommended that 705 HT is calibrated with the target gas it is to detect. Gassing is carried out at the sensor and adjustments are made at the control card.

5.1 No accessories fitted

Where there are no accessories fitted to the sensor, it is recommended that the Sample Flow Housing accessory is used when gassing the sensor (see 5.3). Where this is not possible, a suitable plastic bag may be used.

Caution: Calibration should only be attempted by qualified service personnel.

5.2 Collecting Cone or Weather Protection Housing Fitted

1. Using rubber tubing, connect the test gas to the gassing nozzle or to the permanently connected tubing if fitted to the accessory.

Cautions:

1. *Spring pressure on the gassing nozzle of the Weather Protection Housing accessory forces the nozzle against the sinter. Rotation of the nozzle may damage the sinter if a filter is not fitted.*

2. *Direct gassing of the sensor via the nozzle on the Collecting Cone accessory in wind speeds greater than 5m/s may cause errors.*

2. Set the flow rate to 1.5 ± 0.1 litres per minute and test the system in accordance with the instructions in the relevant system equipment manual.

3. On completion, shut off the test gas and disconnect the rubber tubing.

5.3 Sample Flow Housing Fitted

1. Shut off the sample flow to the Flow Housing.

2. Disconnect the input pipeline from the input nozzle of the Flow Housing.

3. Using rubber tubing, connect the test gas to the Flow Housing input nozzle.

4. Set the flow rate to 1.5 ± 0.1 litres per minute and test the system in accordance with the instructions in the relevant system equipment manual.

5. On completion, shut off the test gas and disconnect the rubber tubing.

6. Reconnect the input pipeline to the Flow Housing input nozzle and restore the sample flow.

7

3. INSTALLATION

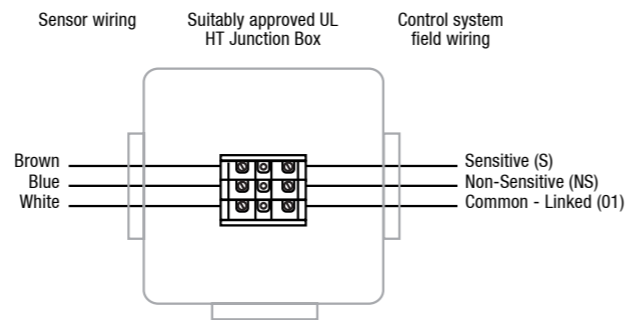

10. If required, fit an accessory to the sensor.

See subsequent instructions. In a clean atmosphere, and where no accessories are to be fitted, a filter is not needed.

11. Power-up the system, calibrate the sensor (if required), and check for correct operation of the gas detector.

Fitting the Weather Housing and Collecting Cone Accessories

1. Fit the previously removed filter to the accessory.

The filter must be fitted to these accessories.

2. Firmly screw the accessory to the body of the sensor.

Note: When fitting a filter, keep it free from oil and dirt and other contaminants.

Fitting the Flow Housing Accessory

1. Ensure the gasket (Part No: 00780-C-0048) is fitted to the Flow Housing.

2. Apply a thin coating of anti-seize compound, such as a light petroleum grease, to the sensor accessory thread.

3. Firmly screw the accessory to the body of the sensor.

Note: When fitting a filter, keep it free from oil and dirt and other contaminants.

4

5. MAINTENANCE

Only a qualified installation engineer should service the sensor. Ensure power is off before carrying out any maintenance procedures.

Maintenance consists of cleaning the sensor and accessories and replacing the filter. Both these can be carried out without removing the sensor from the junction box.

Sensor and accessories may be cleaned using an industrial grade of Methanol, providing the appropriate safety precautions are taken when handling this solvent. Whenever cleaning takes place, a new filter must be fitted.

To change a filter carry out the following procedure:

1. Remove the accessory (if fitted) from the sensor.

2. Remove the old filter and replace with a fresh filter.

3. Replace the accessory (if fitted).

Ensure any seals are refitted/correctly located. The diagram shows the sensor with the Weather Protection accessory fitted.

8

3. INSTALLATION

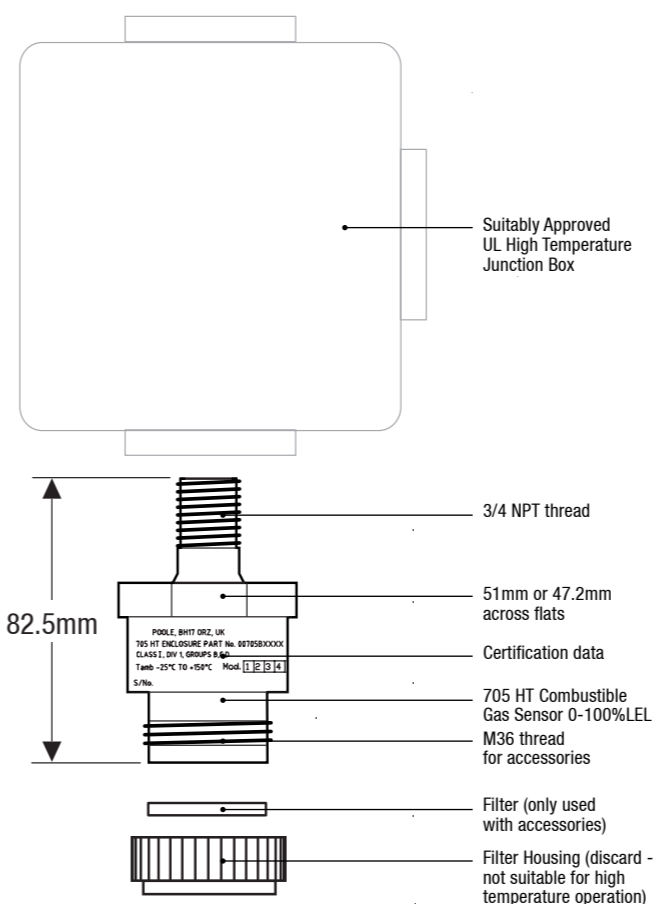

5

5. MAINTENANCE

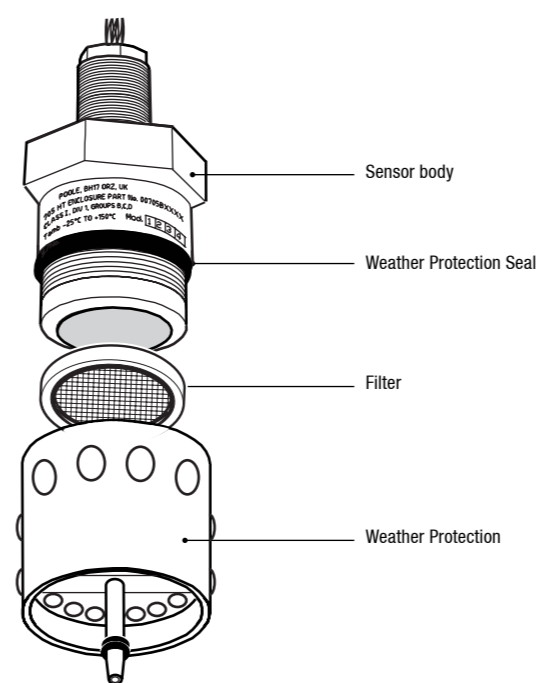

9

3. INSTALLATION

Sensor installation with System 57 components

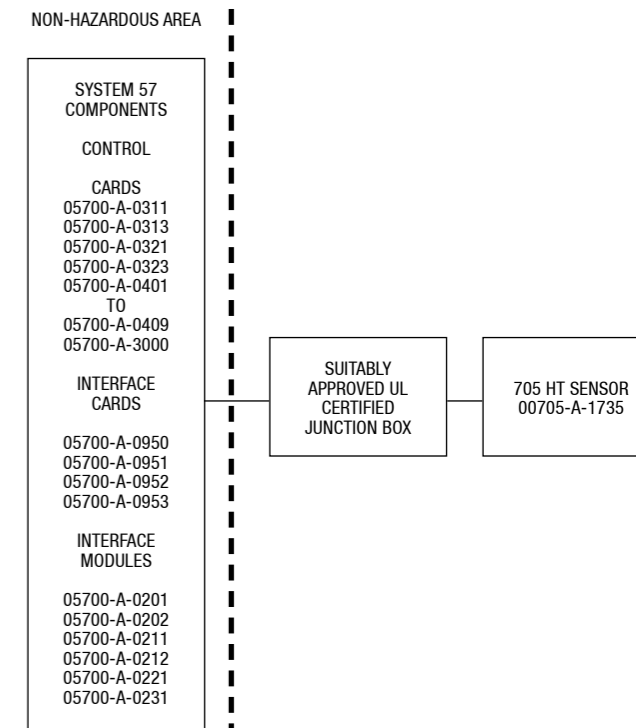

6

6. FAULT FINDING

The following table provides a list of possible faults related to the sensor together with possible causes and remedies.

Fault	Cause/Remedy
Sensor reads non-zero all the time	Gas could be present, ensure there is no combustible gas in the atmosphere
Sensor reads non-zero when no gas is present	Adjust the control system zero setting
Sensor reads low when gas is applied	Adjust the control system span setting
Sensor reads high when gas is applied	Adjust the control system span setting
Sensor reads zero when gas is applied	1. Check the wiring 2. Check that the protective disc has been removed from the filter housing 3. Check that the filter is not dirty/obstructed 4. Replace the sensor if poisoning is suspected

In the event of exposure to contaminant, e.g. silicones or silicone based products, or prolonged exposure to high concentration of gas, the sensor should be operated for 24 hours in a clean environment and then recalibrated.

If the sensor is found to be faulty, or cannot be calibrated, the complete sensor must be discarded and replaced.

10