



9GHz Search  
And Rescue  
Transponder



# CONTENTS

<b>Warnings</b> .....	<b>1</b>
<b>General description</b> .....	<b>2</b>
<b>SART principle of operation</b> .....	<b>2</b>
<b>Installation</b> .....	<b>4</b>
<b>SART General Assembly</b> .....	<b>5</b>
<b>Operating instructions</b> .....	<b>6</b>
<b>Self test facility</b> .....	<b>7</b>
<b>Battery replacement</b> .....	<b>7</b>
<b>Technical description</b> .....	<b>8</b>
<b>Function chart</b> .....	<b>8</b>
<b>Fault Finding</b> .....	<b>8</b>
<b>Servicing</b> .....	<b>8</b>
<b>Dimensions</b> .....	<b>9</b>
<b>Operation of marine radar for SART detection</b> .....	<b>10</b>
Radar Range Scale .....	10
SART Range Errors .....	10
Radar Bandwidth .....	10
Radar Side Lobes .....	10
Detuning the Radar .....	10
Gain .....	10
Anti-Clutter Sea Control .....	11
Anti-Clutter Rain Control .....	11
<b>Technical Specification</b> .....	<b>12</b>
<b>Declaration of Conformity</b> .....	<b>13</b>

## Warnings

- **This SART II is an emergency device for use only in situations of grave and imminent danger.**
- **False alarms cost lives and money. Help to prevent them; understand how to activate and disable your equipment.**
- **Read the complete manual before installing, testing or using the SART II.**
- **The SART II contains no user servicable parts. Return to your dealer for service.**
- **Dispose of this device safely. Contents include Lithium batteries; do not incinerate, puncture, deform or short-circuit.**
- **This device emits radio frequency radiation when activated. Because of the levels and duty cycles, such radiation is not classed as harmful. However, it is recommended that you do not hold the radome while the SART II is activated.**
- **If the security tab is broken, the SART II is not compliant with SOLAS regulations and must be repaired or replaced.**

## Transportation

Because it contains a primary non-rechargeable Lithium battery, the SART II may have special transportation requirements depending on local and international regulations in force at the time.

The battery pack contains 6.2g Lithium in total. Transport the SART II in compliance with applicable regulations for this mass of hazardous material.

## General description

The SART II (**S**earch **A**nd **R**escue **T**ransponder) is designed for survivor location during search and rescue operations.

### CARRY-OFF SART

Supplied as one integral unit. This is normally mounted in a bulkhead bracket (supplied) which is used to stow the unit on the mother vessel. On abandoning to a survival craft the SART II can be carried in one hand off the stricken vessel and mounted through a port in the canopy of the survival craft using the telescopic pole.

The main body of the SART II is high visibility orange thermoplastic, attached to the sealed replaceable battery pack by stainless steel fastenings. The joint is sealed against water ingress by an O-ring.

Operation is by a rotating switch ring providing ON, OFF and TEST functions. The ON position is reached by breaking a security tab. The switch ring is spring loaded so that it returns automatically from the TEST position.

The Lithium battery is fitted with internal overload protection and has a five year storage life. Non-reversible electrical connections are provided in the SART II body and battery pack to facilitate battery replacement.

Each SART II carries a unique serial number on the label on the orange body.

### LIFERAFT SART

Supplied with or without mast. Normally it is packed as part of the liferaft equipment. The mast version is mounted in the same manner as the carry-off version; the version without the mast is intended to be hung from the highest point inside the liferaft.

The SART II itself is identical with the carry-off version.

## SART principle of operation

Actuating a SART enables a survival craft to show up on a search vessel's radar display as an easily recognised series of dots.

RADAR (radio detection and ranging) is a device carried by most ships which is used to determine the presence and location of an object by measuring the time for the echo of a radio wave to return from it, and the direction from which it returns.

A typical ship's radar will transmit a stream of high power pulses on a fixed frequency anywhere between 9.2GHz and 9.5GHz. It will collect the echoes received on the same frequency using a display known as a Plan Position Indicator (PPI), which shows the ship itself at the centre of the screen, with the echoes dotted around it. Echoes further from the centre of the screen are thus further from the ship and the relative or true bearing of each echo can be easily seen.

The SART operates by receiving a pulse from the search radar and sending back a series of pulses in response, which the radar will then display as if they were normal echoes. The first return pulse, if it sent back immediately, will appear in the same place on the PPI as a normal echo would have done. Subsequent pulses, being slightly delayed, appear to the radar like echoes from objects further away. A series of dots is therefore shown, leading away from the position of the SART. This distinctive pattern is much easier to spot than a single echo such as from a radar reflector. Moreover, the fact that the SART is actually a transmitter means that the return pulses can be as strong as echoes received from much larger objects.

A complication arises from the need for the SART to respond to radars which may be operating at any frequency within the 9GHz band. The method chosen for the SART is to use a wideband receiver (which will pick up any radar pulses in the band), in conjunction with a swept frequency transmitter. Each radar pulse received by the SART results in a transmission consisting of 12 forward and return sweeps through the range 9.2GHz to 9.5GHz. The radar will only respond to returns close to its own frequency of operation (ie. within its receive bandwidth), so a "pulse" is produced at the radar input each time the SART sweep passes through the correct frequency.

A slow sweep would give the radar a stronger echo to deal with as the sweep would be inside the operating bandwidth for a longer period. The delay for the sweep to reach the operating frequency may however lead to an unacceptable range error, as delayed echoes appear to be coming from more distant objects.

To minimise this problem, the SART uses a "sawtooth" response, sweeping quickly, then slowly for each of its twelve forward and return sweeps. At long range, only the slow sweeps, giving the strongest returns, are picked up. At close range, where errors are more important, the fast sweeps are also detected. As the first sweep is a fast one, then the range error is minimised and should be less than 150 metres.

The timescale over which all this occurs is very short. Each "fast" sweep takes about 0.4 $\mu$ s, each "slow" sweep about 7.5 $\mu$ s. The complete series of twelve forward and return sweeps is therefore complete within 100 $\mu$ s. Displayed on the PPI, the spacing between each pair of dots will be 0.6 nautical miles.

On a long range setting, a typical radar will be triggering the SART every millisecond - but only during the period that the rotating radar scanner is pointing in the correct direction. Most modern radars use sophisticated noise rejection techniques, which prevent the display of echoes which are not synchronized with the radar's own transmissions, so one radar will not normally be confused by a SART's response to a neighbouring radar.

The SART indicates that it has been triggered by lighting an indicator LED continuously (it flashes in standby mode) and by sounding an integral buzzer. If no radar pulses are detected for a period exceeding 15 seconds, the SART reverts to "standby" mode.

# Installation

The preferred mounting location is inside the vessel, and protected from the elements, usually on the ship's bridge wing. The SART II should be mounted where it will not get in the way of day-to-day operations, but where it can readily be accessed near an emergency exit in the event it is needed.

Do not install the SART II within the ship's radar beam.

Fix the mounting bracket to a bulkhead in a convenient location. The recommended fixing is by M5 marine grade stainless steel (eg A4/316) bolts; length is dependent upon application. The bolts should be secured with either stainless steel locking nuts or stainless steel nuts with stainless steel shakeproof washers.

Mount the SART II, dome uppermost, onto the bracket by locating the lugs on the SART II pole mount into the slots in the bracket. Push down the SART II into place.

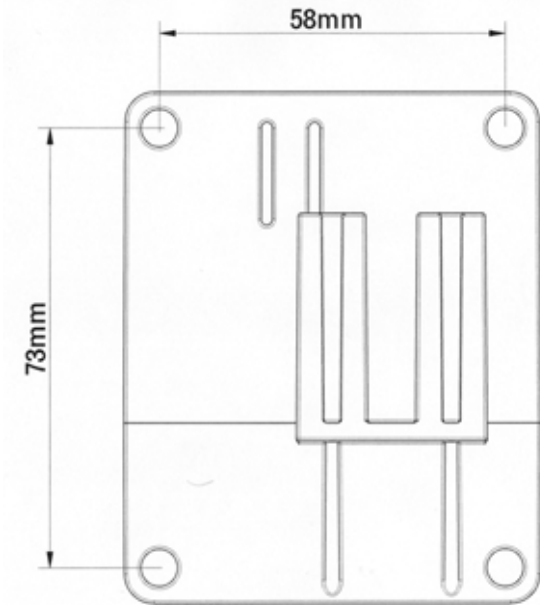
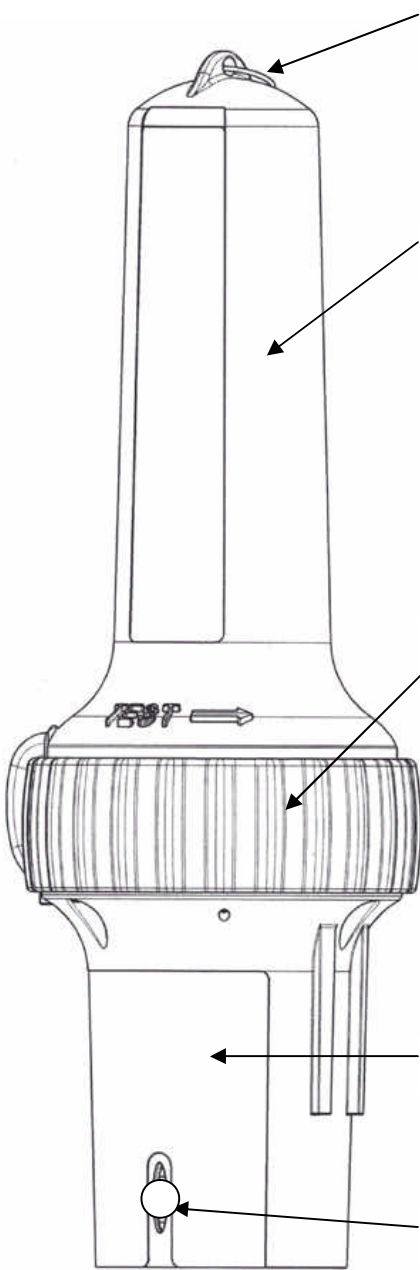

**Figure 1**

Bracket mounting holes: 4 holes, 5.5mm diameter

NOTE: Safe compass distance 1.5m.

# SART General Assembly



Ring for internal liferaft mounting

Radome

Operating switch ring

Battery pack

Lanyard

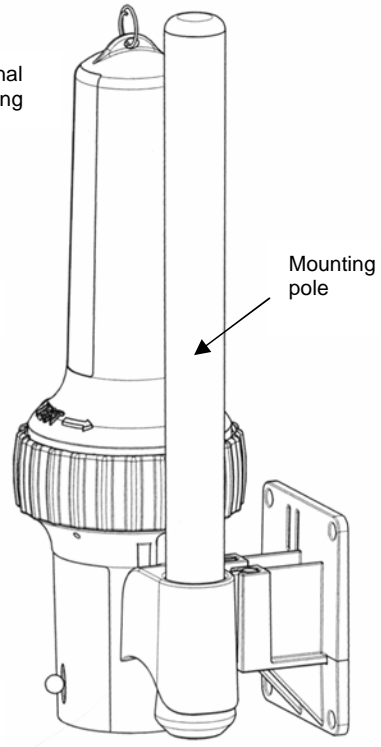

Mounting pole

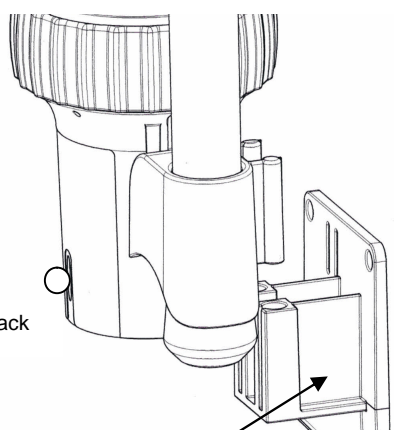

Bulkhead Mounting bracket

# Operating instructions

Remove from bulkhead bracket:

Lift the SART II from the bracket

To switch on:

Break the security tab away from the body of the SART II

Rotate the switch ring clockwise (ie to the left) to the ON position marked by "1"

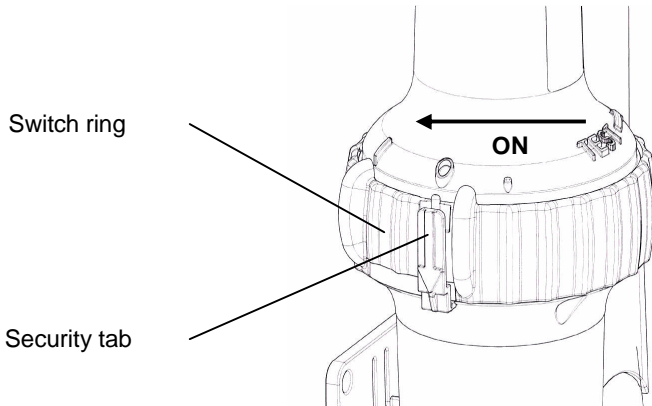

To extend the telescopic pole:

1. Grasp the rubber cover at the bottom of the pole, and twist the pole to release it in the pole mount. Pull the pole down and twist to lock in place in the pole mount.
2. Remove the rubber cover from the bottom of the pole; allow the pole sections to drop. Lock sections together by twisting each section.

To deploy in a survival craft (liferaft):

Extend the SART II supporting pole as described above

Tether the SART II to a suitable point using the lanyard which unwinds from its base

Inset the SARTII through the port in the canopy

Position the bottom of the support pole in the antenna pocket

Secure the pole to the canopy support

Some survival craft have the SART already packed as part of the inventory. In general, these models of SART are not fitted with the support pole. The SART should be switched ON then suspended by its top loop from the highest point of the survival craft.



## Self test facility

Regular testing of the SART II is advised. The duration of the test should be limited to as short a time as possible as the SART II response may be received by other vessels which are within range.

There are no operational differences between TEST and ON modes; the rotary switch must be held in the TEST position, on release it returns to the OFF position.

1. Ensure compliance with all applicable Health and Safety instructions when working in proximity to a radar transmitter.
  2. Locate the SART II within the line of sight of an operating approved marine Radar.
  3. Rotate the switch ring anticlockwise (ie to the right) to the TEST position, and hold it in this position.
    - a) If the SART II responds to the radar, the red light in the base of the SART II will be continuously lit and the buzzer will sound every 2 seconds.
    - b) If the SART II does not respond to the radar, the red light will flash every 2 seconds and the buzzer will not sound.
- The SART II must respond to the radar to pass the test.
4. Switch off the SART II by releasing the switch ring; check that it returns fully to the OFF position.
  5. During the annual survey, perform the self test and verify the SART performance by observing the response on the radar.

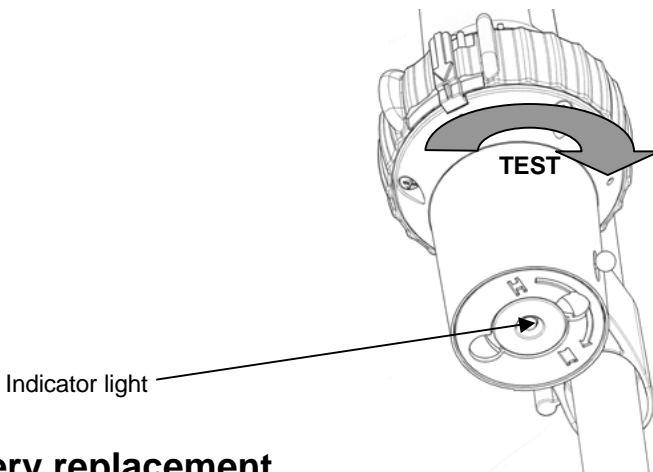

## Battery replacement

The battery should be changed 5 years from the date of manufacture shown on the label or after use.

It is recommended that battery change should only be performed by an authorised service agent, in order that a complete assessment and integrity check can be performed. The replacement battery kit is available from an authorised service agent and contains all necessary components.

## Technical description

A single switched antenna is used for both receive and transmit functions; the switch normally connects the antenna to the receiver circuit. In the standby mode only the receiver portion of the SART II is powered to reduce battery consumption to a minimum. In this condition the indicator circuit causes the LED to flash once every two seconds.

On receipt of a radar pulse the video amplifier and detector circuit causes the rest of the circuitry to become active and the unit switches to transmit mode. In this condition the indicator circuit causes the LED to remain steady and the buzzer to sound every two seconds.

The detection of a radar pulse causes the switch to connect the antenna to the transmitter circuit. The output stage is fed by a Voltage Controlled Oscillator (VCO), whose frequency is determined by a sweep generator. When triggered by the detector the sweep generator turns on the VCO and causes it to produce exactly 12 forward and reverse frequency sweeps before shutting down again.

If no radar pulses are detected for a period of 15 seconds the unit reverts to standby mode.

## Function chart

SART II STATUS	BUZZER	RED LED
OFF	OFF	OFF
STANDBY MODE (TEST or ON)	OFF	FLASHING EVERY 2 SECONDS
ACTIVELY TRANSPONDING (TEST or ON)	ON EVERY 2 SECONDS	ON

## Fault Finding

Fault finding is limited to performing the self test and verifying the SART response on the radar.

## Servicing

The SART contains no user-serviceable parts, and consequently should be returned to an authorised Sailor service agent for repair. Ensure compliance with the appropriate regulations for transportation of Lithium material, as detailed in the Transportation section on the front inside cover.

# Dimensions

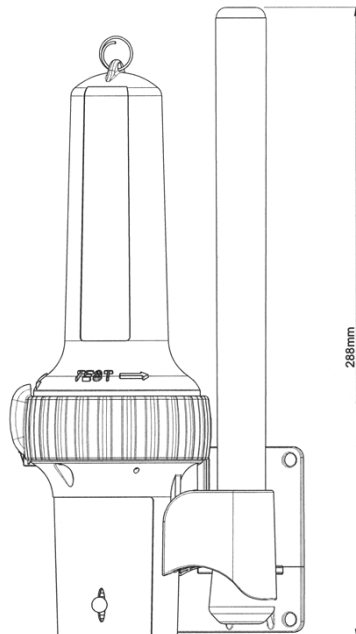
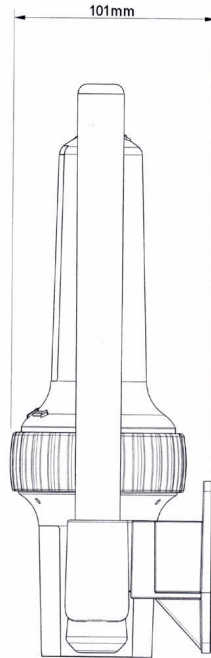
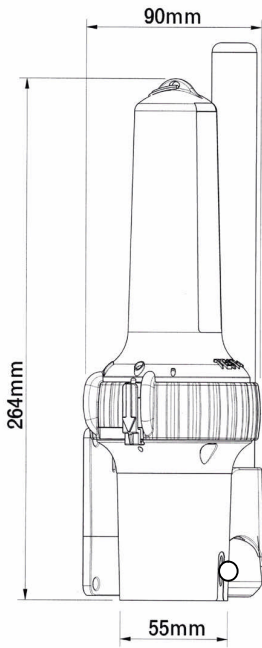

# Operation of marine radar for SART detection

## Radar Range Scale

When looking for a SART it is preferable to use a range scale between 6 and 12 nautical miles. This is because the spacing between the SART responses is about 0.6 nautical miles (1125 metres) and it is necessary to see a number of responses to distinguish the SART from other responses.

## SART Range Errors

There are inherent delays in the SART responses; the SART has a trigger delay and may also have to sweep through the whole radar band before reaching the frequency of the search radar. At medium ranges of about 6 nautical miles the range delay may be between about 150 metres and 0.6 nautical miles beyond the SART position. As the SART is approached the radar delay of the first dot should be no more than 150 metres beyond the SART position.

## Radar Bandwidth

This is normally matched to the radar pulse length and is usually switched with the range scale and the associated pulse length. Narrow bandwidths of 3.5MHz are used with long pulses on long range and wide bandwidths of 10-25MHz with short pulses on short ranges. Any radar bandwidth of less than 5MHz will attenuate the SART signal slightly so it is preferable to use a medium bandwidth to ensure optimum detection of the SART. The Radar operating manual should be consulted about the particular radar parameters and bandwidth selection.

## Radar Side Lobes

As the SART is approached side lobes from the antenna may show the SART responses as a series of arcs or concentric rings. These can be removed by the use of the anti-clutter sea control although it may be operationally useful to observe the side lobes as these will confirm that the SART is near to the ship.

## Detuning the Radar

To increase the visibility of the SART in clutter conditions the radar may be detuned to reduce the clutter without reducing the SART response. Radar with automatic frequency control may not permit manual detuning of the equipment. Care should be taken in operating the radar detuned, as other wanted navigational and anti-collision information may be removed. The tuning should be returned to normal operation as soon as possible.

## Gain

For maximum range SART detection, the normal maximum gain should be used.

## Anti-Clutter Sea Control

For optimum range SART detection, this control should be set to the minimum. Care should be exercised as targets in sea clutter may be obscured. Some radar sets have automatic/manual anti-clutter sea control facilities in which case the operator should switch to manual.

## Anti-Clutter Rain Control

This should not be used when trying to detect SARTs as the SART responses may be removed by this control. Some sets have automatic/manual anti-clutter rain control facilities in which case the operator should switch to manual.

## Radar Displays

These sketches show the appearance of a SART response at different ranges.

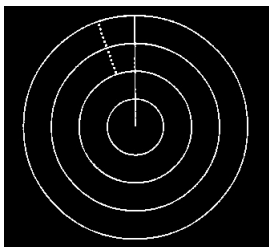

**SART response  
from distant  
liferaft (5-6 miles)**

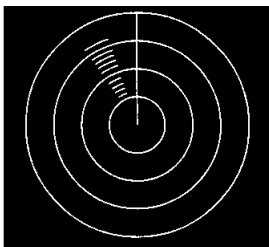

**SART response  
from liferaft at  
medium range (2-3  
miles).  
Note widening of  
“echos”**

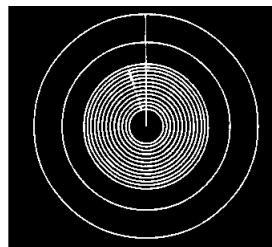

**SART response  
close to vessel  
(<1 mile).  
Display now  
shows “rings”  
caused by  
strength of  
signal**

# Technical Specification

FREQUENCY:	9.2GHz - 9.5GHz
POLARIZATION:	Horizontal
SWEEP RATE:	5 $\mu$ s per 200MHz nominal
RESPONSE SIGNAL:	12 sweeps
FORM OF SWEEP:	Forward: 7.5 $\mu$ s $\pm$ 1 $\mu$ s
	Reverse: 0.4 $\mu$ s $\pm$ 0.1 $\mu$ s
PULSE EMISSION:	100 $\mu$ s nominal
EIRP:	>400mW (+26dBm)
RX SENSITIVITY:	Better than -50dBm (0.1 mW/m <sup>2</sup> ) (Note 1)
DURATION:	96 hours in standby condition followed by a minimum of 8 hours of transmission while being continuously interrogated with a pulse repetition frequency of 1kHz.
TEMP RANGE:	Operating: -20 <sup>o</sup> C to +55 <sup>o</sup> C
	Storage: -30 <sup>o</sup> C to +65 <sup>o</sup> C
RECOVERY TIME:	Following excitation: 10 $\mu$ s or less
ANTENNA HEIGHT:	Greater or equal to 1m (Note 2)
RESPONSE DELAY:	0.5 $\mu$ s or less
ANTENNA BEAM:	Vertical: +/-12.5 degrees
	Azimuth: Omnidirectional to +/-2dB
WEIGHT:	SART II only: 360g
	SART II + pole: 510g
	SART II complete: 530g
DIMENSIONS:	Overall, in bracket: 288 x 101 x 90mm
BUOYANCY:	Buoyant

## Note

1. Effective receiver sensitivity includes antenna gain.
2. The effective antenna height applies to equipment required to meet Regulation 6.2.2 of Chapter III and 7.1.3 and 8.3.1 of Chapter IV of the 1988 Amendments to the 1974 SOLAS Convention.

## Standards

Complies with IMO Resolution A.802(19)

Test and Approval Standards are specified on the Declaration of Conformity following.

# Declaration of Conformity

Silver Point  
Airport Service Road  
Portsmouth  
Hampshire UK  
PO3 5PB  
Int + 44 (0)23 9262 3900  
[www.mcmurdo.co.uk](http://www.mcmurdo.co.uk)



## EC DECLARATION OF CONFORMITY

The following products comply with the essential requirements of Council Directive 96/98/EC on the approximation of the laws of the member States relating to Marine Equipment as amended by Commission Directives 98/85/EC, 2001/53/EC, 2002/75/EC and 2002/84/EC, and by the application of an EC Type Examination Certificate as detailed overleaf.

### Products covered by this Declaration

Product Type: **Search and Rescue Transponder (SART)**

Models: **McMurdo S4 RESCUE SART  
Sailor SART II  
Skanti SART II  
RFD S4 RESCUE SART**

### Intended usage of products

All vessels which must comply with IMO SOLAS regulations in coastal or International waters.

Surveillance conformity assessment is undertaken in accordance with Production Quality Assurance Module D by:

Lloyd's Register (No. 0038)  
71 Fenchurch Street  
London EC3M 4BS  
United Kingdom

The product will carry this Conformity Marking:

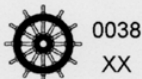

Issued on behalf of McMurdo Limited

Signed :

Name: **C P Hoffman**  
Title: **Technical Director**

Date: **30 NOV 2004**

# Declaration of Conformity (page 2)

**Technical Construction File held by:**  
**McMurdo Limited**  
**Silver Point, Airport Service Road, Portsmouth PO3 5PB UK**

**Regulations and Standards applied:**  
SOLAS74, as amended, Regulations III/4, III/6.2.2, IV/7.1.3, IV/14 and X/3  
IMO Resolution MSC.97(73), 2000HSC Code, 8.2.1.2, 13.17.1, 14.7.1.3  
IMO Resolutions A.530(13), A.694(17), A.802(19), A.813(19)  
ITU-R M.628-3 (11/93)  
EN 61097-1 (1993), IEC 61097-1 (1992), EN 60945 (2002), IEC 60945 (2002)

**EC Type Examination Certificate:-**  
**Name of Notified Body :** Lloyd's Register (No. 0038)  
**Address of Notified Body :** 71 Fenchurch Street, London EC3M 4BS, UK  
**EC Type Examination Certificate :** MED 0450285 05 October 2004

### ATTENTION

The attention of the specifier, purchaser, installer, or user is drawn to special measures and limitations to use which must be observed when the product is taken into service to maintain compliance with the above directive. Details of these special methods and limitations to use are available on request, and are also contained in the product installation and operator manuals.



BS EN ISO 9001, BS9000/CECC and CAA Approved  
Registered in England No. 746603  
Registered Office: 1650 Parkway, Whiteley, Fareham, Hampshire, PO15 7AH  
VAT No: GB 421 1393 92













# SAILOR

When safety counts

SAILOR® · Porsvej 2 · PO Box 7071 · 9200 Aalborg SV · Denmark

Tel: +45 9634 6100 · Fax: +45 9634 6101 · [sailor@sailor.dk](mailto:sailor@sailor.dk) · [www.sailor.dk](http://www.sailor.dk)

86-920-005 Issue 3