



ADVANCED MANUAL

HF ALL BAND TRANSCEIVER
IC-718



Thank you for choosing this Icom product. This product is designed and built with Icom's state of the art technology and craftsmanship. With proper care, this product should provide you with years of troublefree operation.

ABOUT THE MANUALS

You can use the following manuals to understand and operate this transceiver. (As of January 2024)

TIP: You can download each manual and guide from the Icom website.

<https://www.icomjapan.com/support/>

Enter "IC-718" into the Search box in the site.

- **Basic manual (Comes with the transceiver)**

Instructions for basic operations.

- **Advanced manual (This manual)**

Instructions for advanced operations.

For Reference

- **HAM Radio Terms (PDF type)**

A glossary of HAM radio terms in English.

TRADEMARKS

Icom and the Icom logo are registered trademarks of Icom Incorporated (Japan) in Japan, the United States, the United Kingdom, Germany, France, Spain, Russia, Australia, New Zealand, and/or other countries. All other products or brands are registered trademarks or trademarks of their respective holders.

Section 1 **ADVANCED CONNECTIONS**

Advanced connections	1-2
◇ Front panel	1-2
◇ Rear panel.....	1-2
Connecting a non-Icom linear amplifier.....	1-3

Advanced connections

◇ Front panel

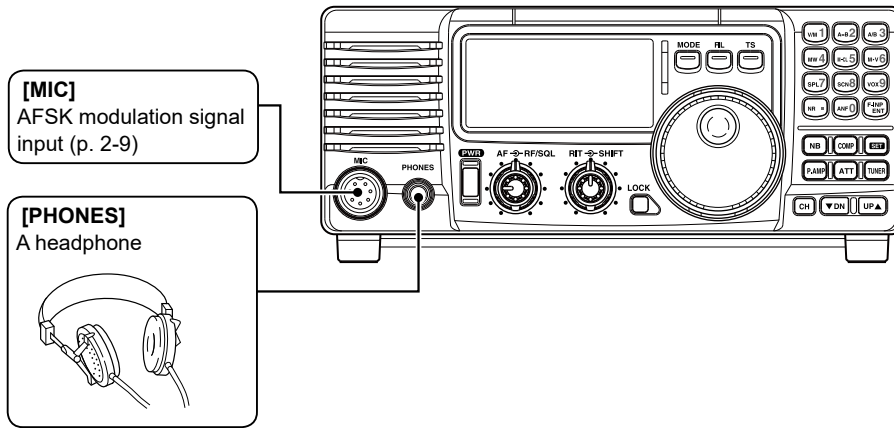

◇ Rear panel

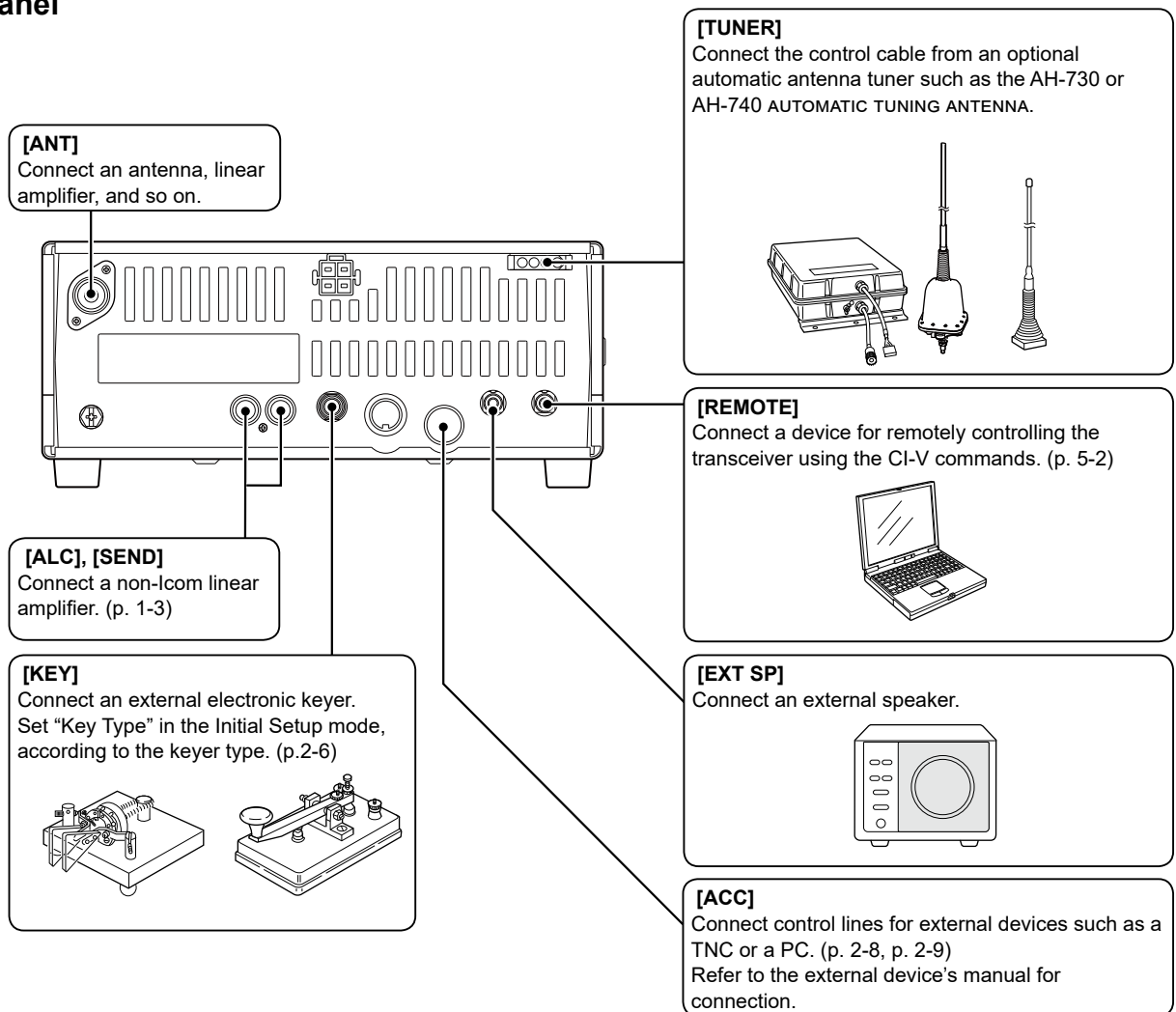

Connecting a non-Icom linear amplifier

⚠ WARNING!

- Set the transceiver output power and linear amplifier ALC output level referring to the linear amplifier's manual.
- The ALC input level must be from 0 V to -4 V.
- The transceiver does not accept a positive voltage. Therefore, unmatched ALC and RF power settings could cause a fire or ruin the linear amplifier.

NOTE: The specifications for the SEND relay are 16 V DC 2 A. Above this level, larger external relays must be used.

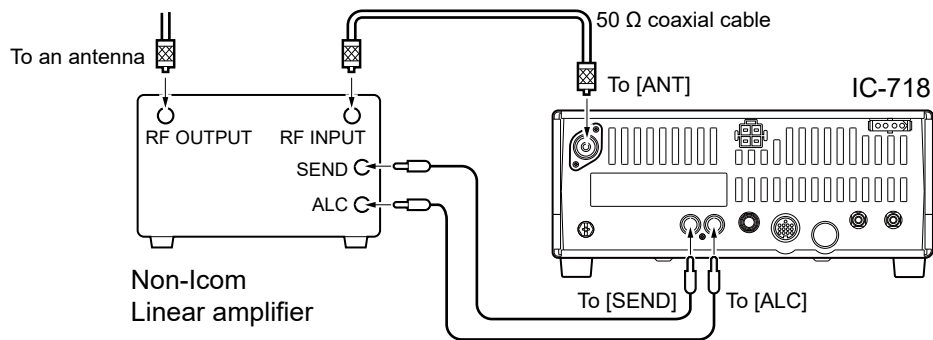

Measuring SWR	2-2
Using an external antenna tuner	2-3
◇ Using the AT-180	2-3
◇ Optional external tuner operation	2-4
Operating CW	2-5
◇ Connection for CW	2-5
◇ Setting the CW pitch control	2-5
◇ The electronic Keyer function	2-6
◇ Using the Break-in function	2-7
◇ About the CW Reverse mode	2-7
Operating RTTY	2-8
◇ Connections for RTTY (FSK)	2-8
◇ RTTY (FSK) operation	2-8
◇ Connections for RTTY (AFSK)	2-9
◇ RTTY (AFSK) operation	2-9

Measuring SWR

The IC-718 has a built-in circuit to measure antenna SWR. No external equipment or special adjustments are necessary.

1. Confirm that the output power is over 30 W.
2. Push [SET] to display the SWR meter.
 - "SWR" is displayed.

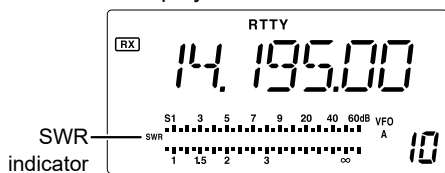

3. Push [MODE] to select CW or RTTY mode.
4. Push down the Key or push [PTT] to transmit, and then read the actual SWR from the meter.
 - ≤ 1.5 : Well matched antenna.
 - ≥ 1.5 : Check the antenna or the cable connection, and so on.

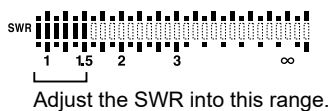

Using an external antenna tuner

◇ Using the AT-180

The AT-180 AUTOMATIC ANTENNA TUNER automatically matches the IC-718 to the antenna. Once the tuner matches the antenna, the tuning settings are memorized as a preset point for each frequency range (100 kHz steps). Therefore, when you change the frequency range, the tuning circuits are automatically set to the memorized point.

CAUTION:

- **DO NOT** transmit without antenna when the tuner is ON. This will damage both the transceiver and the antenna tuner.
- **DO NOT** connect the AT-180 and another antenna tuner at the same time. Both tuners will not be function correctly.

Setting the tuner type

1. Hold down [PWR] for 1 second to turn OFF the transceiver.
2. While holding down [SET], push [PWR] to enter the Initial Set mode.
3. Push [UP▲] or [▼DN] to select "TUNER."
4. Rotate [MAIN DIAL] to select "18" (AT-180).

CAUTION: DO NOT select "4" (AH-4 AUTOMATIC ANTENNA TUNER), otherwise the transceiver automatically transmits when you turn ON the transceiver. If you select a incorrect option, push [TUNER] to cancel the unexpected transmission and select the correct tuner type.

5. Hold down [PWR] for 1 second to turn OFF the transceiver.
6. Push [PWR] to turn ON with the new setting.

Auto tuning

- Push [TUNER] to turn the tuner ON.
 - The antenna is tuned automatically during transmission when the antenna SWR is higher than 1.5:1.
 - When the tuner is turned OFF, "[TUNE]" disappears.

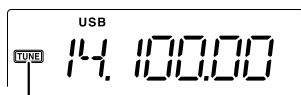
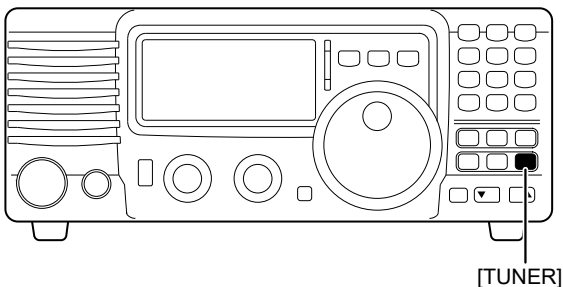

Tuning indicator

Manual tuning

During the SSB operation at low voice levels, the AT-180 may not tune correctly. In such cases, manual tuning is helpful.

- Hold down [TUNER] for 1 second to start a manual tuning.
 - The CW mode is selected, a side tone is emitted, "[TUNE]" blinks, and then the previous mode is selected.

If the tuner cannot reduce the SWR to less than 1.5:1 after 20 seconds of tuning, the tuner circuit is bypassed and "[TUNE]" disappears. In this case, check:

- The antenna connection and feedline
- The antenna SWR.

Through inhibit

The AT-180 has a through inhibit mode.

When selecting this mode, you can use the tuner at poor SWR's. In this case, an automatic tuning in the HF bands is activated only when exceeding an SWR of 3:1. Therefore, a manual tuning will be necessary each time you change the frequency. Although termed "through inhibit," the signal will pass "through" the tuner if the SWR is higher than 3:1 after tuning.

TIP

• Tuner sensitive condition

If you require critical tuning at any time during transmission, select the tuner sensitive condition. (p. 2-2)

• Automatic tuner start

If you want to turn OFF the tuner when the VSWR is 1.5:1 or less, set "AT TUNE" (Auto Tune) in the Initial Set mode to "oF" (OFF).

Using an external antenna tuner

◇ Optional external tuner operation

⚠ **DANGER! HIGH VOLTAGE! NEVER** touch the antenna element while tuning or transmitting. Always place it in a secure place.

CAUTION: DO NOT operate the external antenna tuner without an antenna connected. The tuner and transceiver will be damaged.

NEVER operate the external antenna tuner if it is not grounded.

NOTE: Transmitting before tuning may damage the transceiver. The AH-4 cannot tune when using a $\frac{1}{2} \lambda$ long wire or multiple of the operating frequency.

AH-4 and AH-730

The AH-4 and AH-730 matches the IC-718 to a long wire antenna more than 7 m/23 ft long (3.5 MHz and above).

- See page 3-4 for connection details.
- See also the antenna tuner's instruction manual for installation and connection details.

AH-740

The optional AH-740 covers 2.5 to 30 MHz range with a supplied whip antenna element. Or when using with the optional NVIS kit, it covers 2.2 to 30 MHz range.

- See page 3-4 for connection details.
- See the AH-740 instruction manual for the installation and connection details.

Tuner operation

NOTE: Antenna tuning is necessary for each frequency.

Retune the antenna before transmitting when you change the frequency, even slightly.

Setting the tuner type

1. Hold down [PWR] for 1 second to turn OFF the transceiver.
2. While holding down [SET], push [PWR] to enter the Initial Set mode.
3. Push [UP▲] or [▼DN] to select "TUNER."
4. Rotate [MAIN DIAL] to select "4" (AH-4).
① Also select "4" when using the AH-730 or AH-740.
5. Hold down [PWR] for 1 second to turn OFF the transceiver.
6. Push [PWR] to turn ON with the new setting.

Manual tuning

1. Set the operating frequency an HF band.
 - The transceiver will not transmit outside the ham bands.
2. Hold down [TUNER] for 1 second to start a manual tuning.

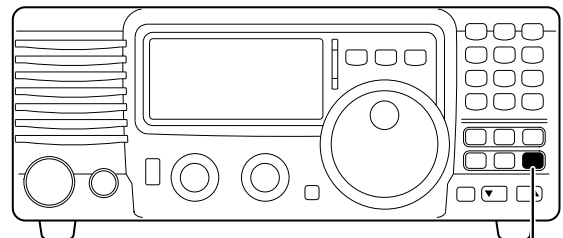

[TUNER]

- "[TUNER]" blinks and "CW" is displayed while tuning.
- "[TUNER]" is continuously displayed when the tuning has been completed.

① When the tuning has not been successful, "[TUNER]" disappears and the antenna tuner is passed through.

① To manually bypass the antenna tuner, push [TUNER] to turn it OFF.

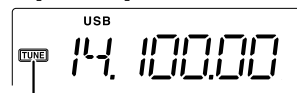

Tuning indicator

- Blinks while tuning.
- Displayed when the tuning is completed.
- Disappears when the tuning could not be completed.

Operating CW

◇ Connection for CW

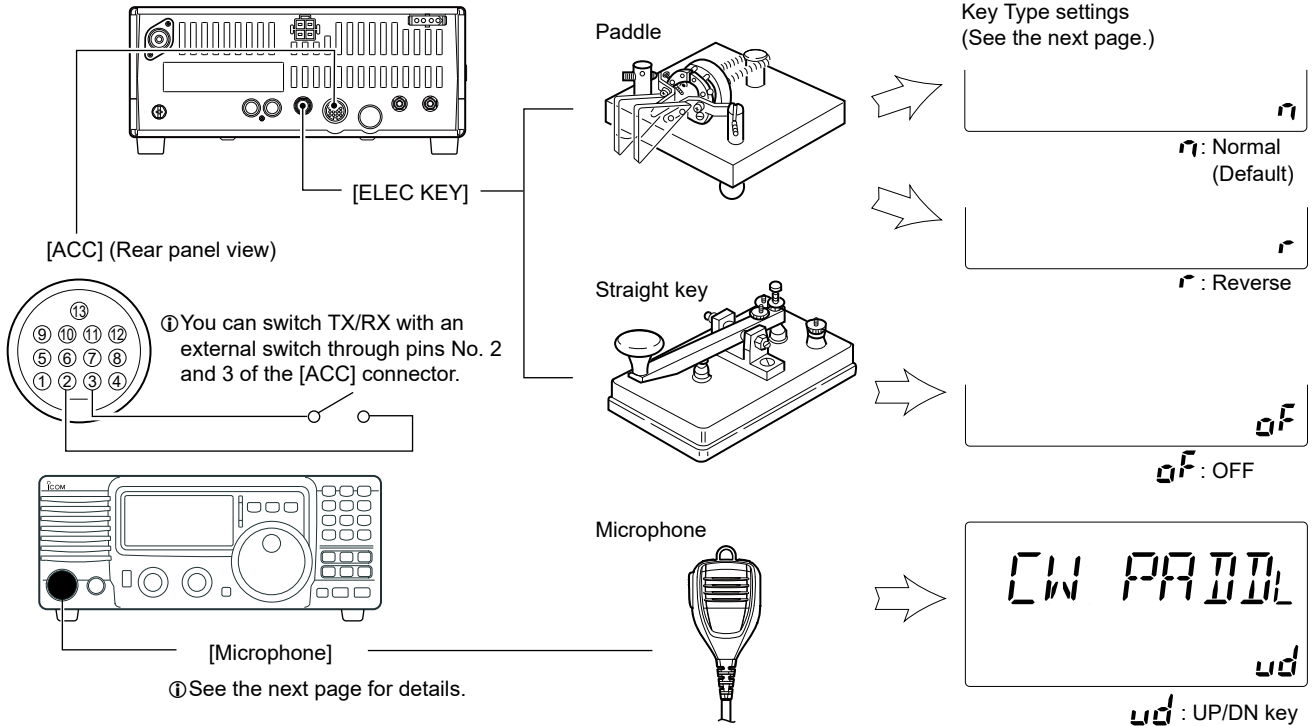

◇ Setting the CW pitch control

You can set the received CW audio pitch and the CW side tone to suit your preference, without changing the operating frequency.

1. Hold down [SET] for 1 second to enter the Quick Set mode.
2. Push [▼DN] or [UP▲] to select "CW PITCH."

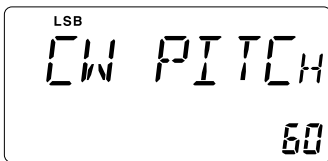

3. Rotate [MAIN DIAL] to set the pitch to between 30 (300 Hz) and 90 (900 Hz).
4. Push [SET] to exit the Quick Set mode.

Operating CW

◇ The electronic Keyer function

The IC-718 has an built-in electronic keyer.

Setting the Key type

1. Push [MODE] to select the CW mode.
2. While holding down [SET], push [PWR] to turn ON the transceiver.
 - Enters the Initial Set mode and a setting item is displayed.
3. Push [UP▲] or [▼DN] to select "CW PADDL."
4. Rotate the [MAIN DIAL] to set the paddle type.
 - n: Normal (Default) (for an electronic keyer)
 - r: Reverse (for an electronic keyer)
 - oF: Turns OFF the electronic keyer (for a straight key)
 - ud: For using the microphone's Up/Down keys instead of the paddle
 - ① In this case, you cannot use squeeze keying.
5. Hold down [PWR] for 1 second to turn OFF the transceiver.
6. Push [PWR] to turn ON the transceiver with the revised settings.

Setting the keying weight

1. Push [SET] to enter the Quick Set mode.
2. Push [UP▲] or [▼DN] to select "KEY RAT."
3. Rotate the [MAIN DIAL] to set weight to between 2.8 and 4.5.
4. Push [SET] to exit the Quick Set mode.

Keying weight example: morse code "K"

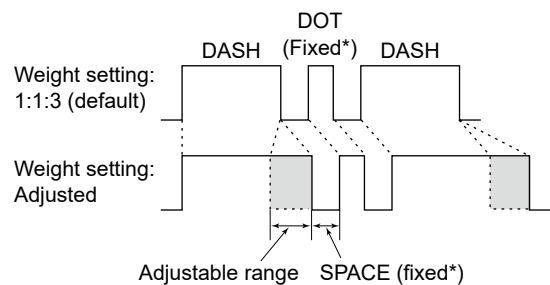

* SPACE and DOT length can be adjusted in "KEY SPD" setting in the Quick Set mode.

Paddle operation from the [MIC] connector

Connect a CW paddle to the [MIC] connector on the front panel to operate the built-in electronic keyer.

① This function is usable only on the [MIC] connector on the front panel.

Paddle operation

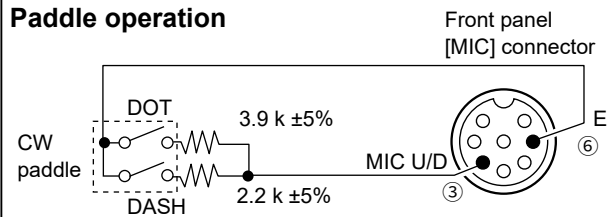

① Connect a straight key to "DOT." side.

Setting the key speed

You can set the keying speed of the internal electronic keyer.

1. Hold down [SET] for 1 second to enter the Quick Set mode.
2. Push [▼DN] or [UP▲] to select "KEY SPD."

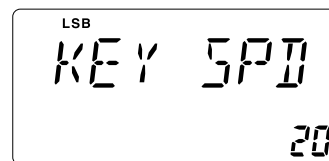

3. Rotate [MAIN DIAL] to set the key speed to between 20 and 60 wpm.
 - ① Some value may not be selectable.
4. Push [SET] to exit the Quick Set mode.

Operating CW

◇ Using the Break-in function

Use the Break-in function in the CW mode to automatically switch between transmit and receive when keying. The IC-718 is capable of operating in the Semi Break-in and Full break-in modes.

• Semi Break-in operation

In the Semi Break-in mode, the transceiver transmits when keying, and then automatically returns to receive after a preset time after you stop keying.

① "BK" is displayed while Semi break-in is selected.

• Full Break-in operation

In the Full Break-in mode, the transceiver automatically transmits while keying down, and then immediately returns to receive after keying up.

① "F-BK" is displayed while Full break-in is selected.

Setting the Break-in function

Before using the Break-in function, set the following items in the Quick Set mode.

• BK-IN (Break-in)

Set the Break-in type from oF (OFF), SE (Semi break-in), or FL (Full break-in).

① "BK" is displayed while Semi break-in is selected or "F-BK" is displayed while Full break-in is selected.

• BK-DELAY (Break-in Delay)

Sets the delay time the transceiver returns to receive after the desired delay time after you stop

1. Push [MODE] to select the CW (or CW-R) mode.
2. Hold down [SET] for 1 second to enter the Quick Set mode.
3. Push [UP▲]/[▼DN] to select the "BK-IN."
4. Rotate [MAIN DIAL] to set the Break-in type.

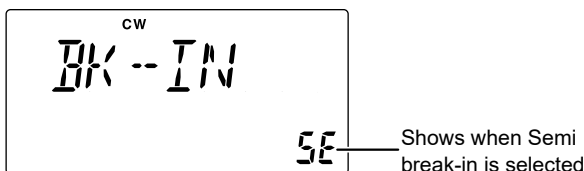

5. Push [UP▲]/[▼DN] to select the "BK-DELAY."
6. Rotate [MAIN DIAL] to set the Break-in delay time.

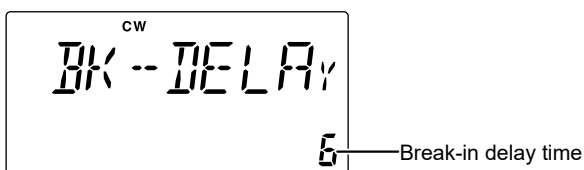

7. To exit the Quick Set mode, push [SET].

◇ About the CW Reverse mode

The CW-R (CW Reverse) mode reverses the receive Beat Frequency Oscillator (BFO) to receive CW signals.

Use this mode when interfering signals are near the desired signal, and you want to use the CW-R to reduce interference.

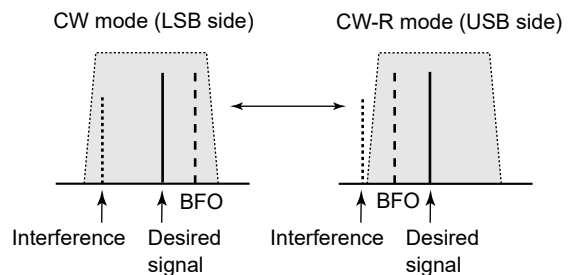

1. Push [MODE] to select the CW mode.
2. Hold down [MODE] for 1 second to toggle between the CW and CW-R modes.
 - **REV** is displayed when the CW-R mode is selected.

Operating RTTY

◆ Connections for RTTY (FSK)

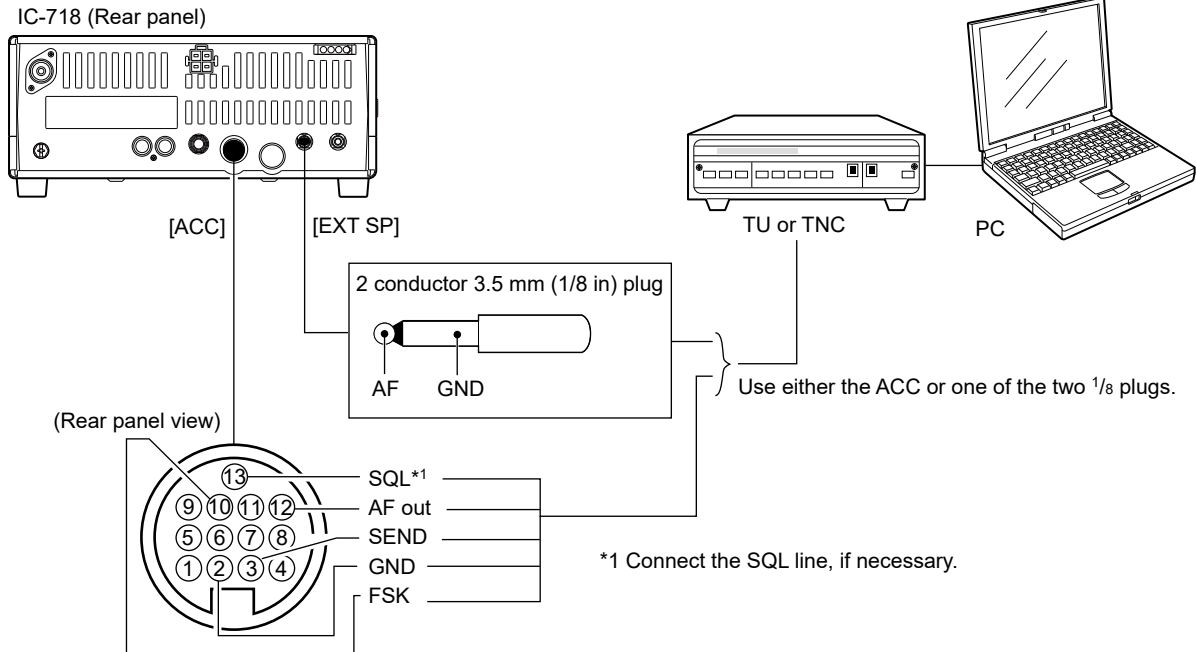

◆ RTTY (FSK) operation

1. Select the RTTY mode by pushing [MODE].
 ① Hold down [MODE] for 1 second to select RTTY-R (reverse) mode, if necessary.
2. Select the desired tone and shift frequencies.
3. Set the desired operating frequency by rotating [MAIN DIAL].
4. Start using the PC or TNC (TU).

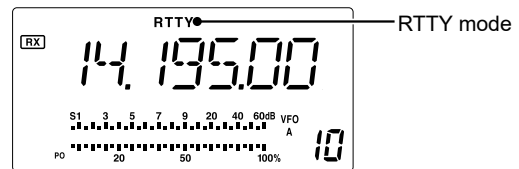

Presetting for RTTY

Before operating RTTY, set the following items in the Quick Set mode.

1. Hold down [SET] for 1 second to enter the Quick Set mode.
2. Push [UP▲]/[▼DN] to select a setting item.
3. Rotate [MAIN DIAL] to set a value.
 - **Tone frequency** "TON 2125"
Select a tone frequency.
 - **Shift frequency** "SIFT 170"
Select the desired shift frequency.
4. Push [SET] to exit the Quick Set mode.

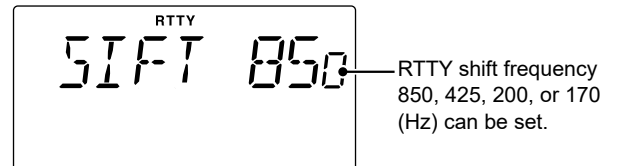
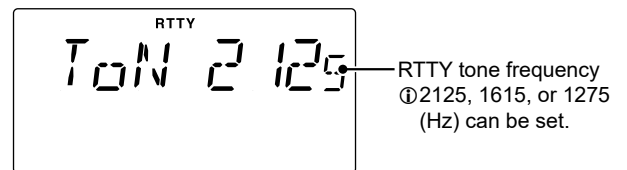

RTTY reverse mode

Received characters are occasionally garbled when the receive signal is reversed between MARK and SPACE. This reversal can be caused by incorrect TNC connections, settings, commands and so on.

To receive a reversed RTTY signal correctly, select the RTTY-R (RTTY reverse) mode.

- **REV** is displayed when the RTTY reverse mode is selected.

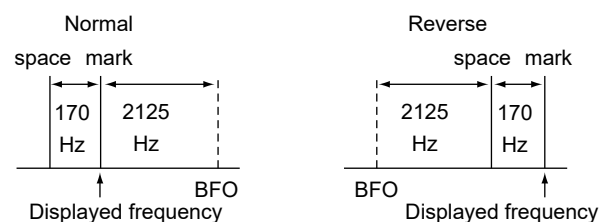

Operating RTTY

◇ Connections for RTTY (AFSK)

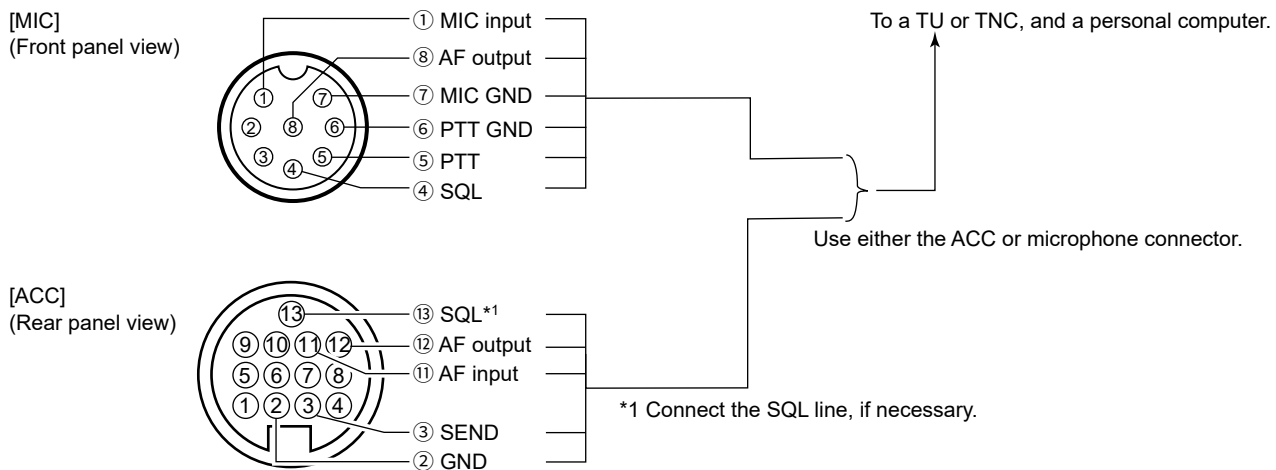

◇ RTTY (AFSK) operation

1. Select the SSB (LSB) mode by pushing [MODE].
① Usually LSB is used on the HF bands.
2. Select the desired FSK tone frequency, shift frequency, and keying polarity, as described on the previous page.
3. Set the desired operating frequency by rotating [MAIN DIAL].
4. Start using the PC or TNC (TU).

Section 3 OPTIONS

Options	3-2
Carrying handle	3-3
Mobile mounting bracket	3-3
Connecting an external antenna tuner	3-4
◇ Using the AT-180	3-5

Options

(As of January 2024)

Microphones

HM-219 HAND MICROPHONE

The same as supplied.

SM-30 DESKTOP MICROPHONE

SM-50 DESKTOP MICROPHONE

Speaker

SP-41 EXTERNAL SPEAKER

Antennas

AT-180 HF + 50 MHz AUTOMATIC ANTENNA TUNER

AH-4 HF + 50 MHz AUTOMATIC ANTENNA TUNER

To tune a long wire antenna for portable or mobile HF operation.

Input power rating: 120 W

AH-2b ANTENNA ELEMENT

A 2.5 m long antenna element for mobile operation with the AH-4.

Frequency coverage: 3.5 MHz ~28 MHz bands with the AH-4

AH-710 FOLDED DIPOLE ANTENNA

AH-730 AUTOMATIC ANTENNA TUNER

Fast Tune-up from 1.8 to 50 MHz Band

Input power rating: 150 W Maximum

AH-740 AUTOMATIC TUNING ANTENNA

Frequency coverage with 1.54 m whip antenna:
2.5 MHz ~29.9999 MHz

Cables

OPC-599 ADAPTER CABLE

13-pin, ACC connector to 7-pin +8-pin ACC connectors.

OPC-2321 CONTROL CABLE

To connect the AH-740

Approximately 6 m, 19.7 feet

Others

MB-23 CARRYING HANDLE

MB-118 MOBILE MOUNTING BRACKET

3 OPTIONS

Carrying handle

The MB-23 CARRYING HANDLE allows you to easily carry and transport the transceiver.

Attach the MB-23 with the supplied rubber feet, as shown to the right.

NOTE: Use only the supplied screws to attach the handle. Otherwise, the handle may not be attached correctly and may drop the transceiver.

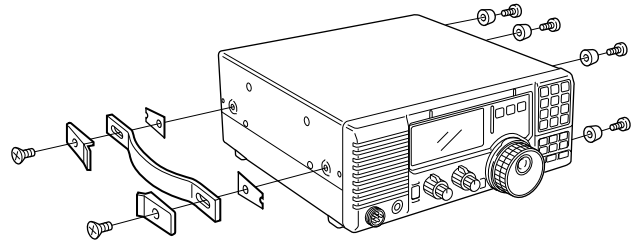

Mobile mounting bracket

The MB-118 MOBILE MOUNTING BRACKET can be used for fixed mounting.

Securely mount the transceiver with the 4 supplied screws (5 × 20) to a thick surface that can support more than 3.8 kg (8.4 lb).

CAUTION: DO NOT use non-supplied screws (longer than 8 mm; 5/16 in) or bolts. Otherwise, the internal equipment of the transceiver may be damaged.

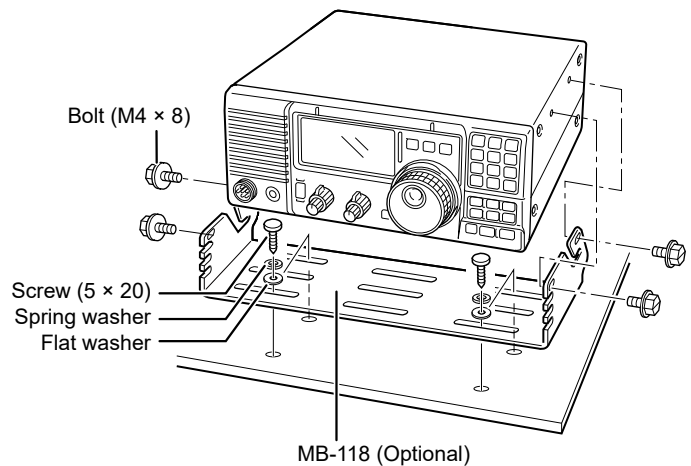

Connecting an external antenna tuner

You can connect an optional external antenna tuner. See page 2-4 and the antenna tuner's manual for details.

DO NOT connect two or more antenna tuners at the same time. Both tuners will not function correctly.

NOTE: Before connecting the antenna tuner, turn OFF the transceiver. Otherwise, the transceiver and the antenna tuner may be damaged.

Example 1: AH-4 AUTOMATIC ANTENNA TUNER

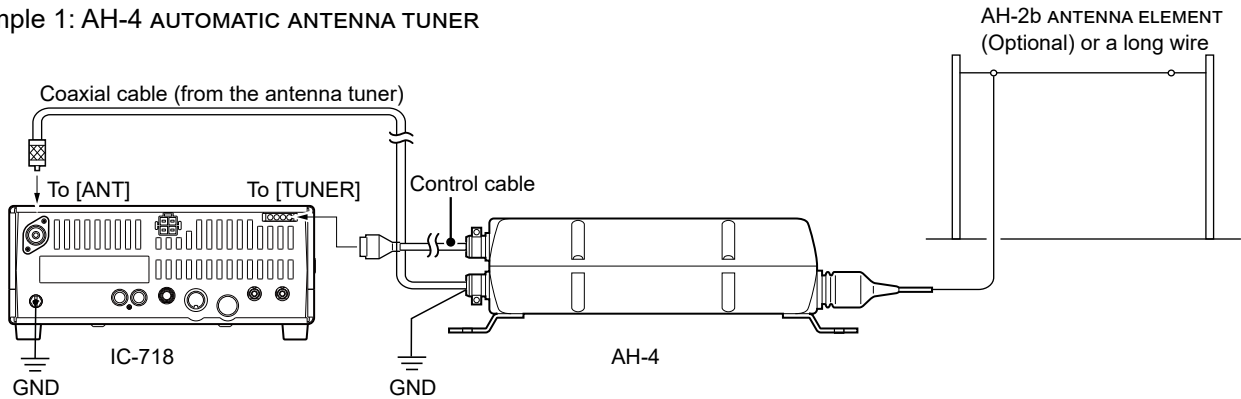

Example 2: AH-730 AUTOMATIC ANTENNA TUNER

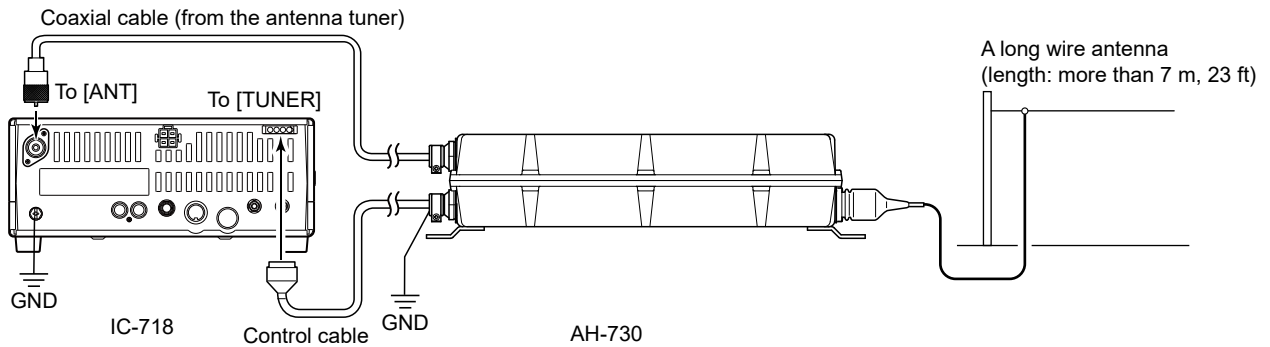

Example 3: AH-740 AUTOMATIC TUNING ANTENNA

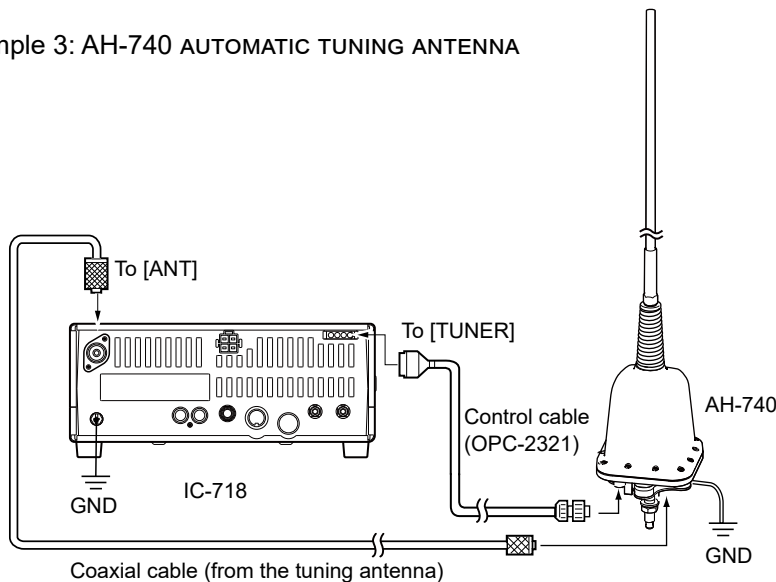

3 OPTIONS

Connecting an external antenna tuner

◇ Using the AT-180

See also page 2-3 for the tuning operation.

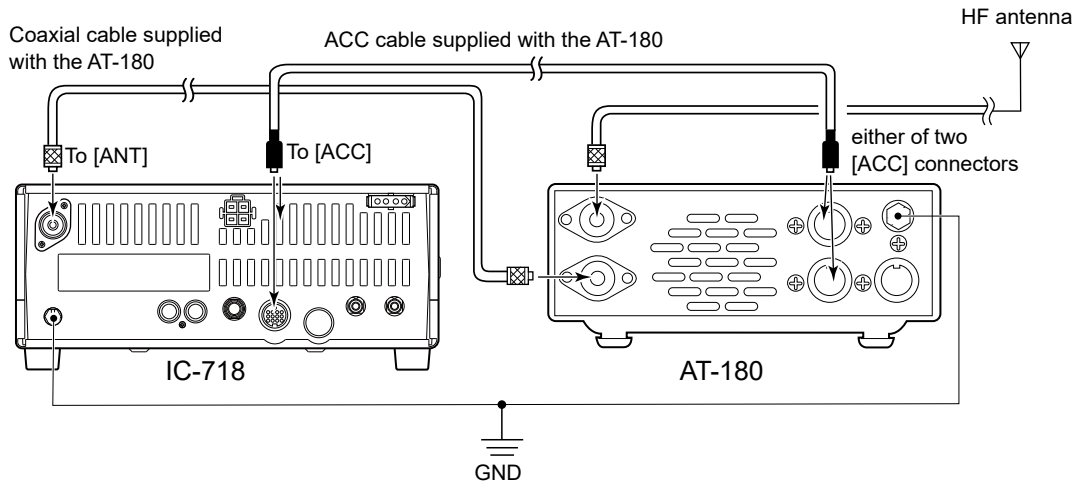

Setting the internal switches

The optional AT-180 has 3 operating settings. Select the suitable setting for your antenna system.

1. Remove the top cover of the AT-180.
2. Set the tuner switches to the desired positions according to the table below.

SW	Position	Operation
S1	A (default)	The tuner operating settings are set with S2.
	B	THROUGH INHIBIT MODE The tuner tunes the antenna even when the antenna has poor SWR (up to VSWR 3:1 after tuning). In this case, manual tuning is necessary each time you change the frequency, although the tuner automatically starts tuning when the VSWR is higher than 3:1. This setting is called "through inhibit." However, the tuner is set to "through" if the VSWR is higher than 3:1 after tuning.
S2	C	TUNER SENSITIVE MODE The tuner tunes each time you transmit (except in the SSB mode). Therefore, the lowest SWR is obtained at any given time. In the SSB mode, the setting is the same as the "D" position.
	D (default)	NORMAL MODE The tuner tunes when the SWR is higher than 1.5:1. Therefore, the tuner activates only when tuning is necessary.

AT-180 inside the top cover

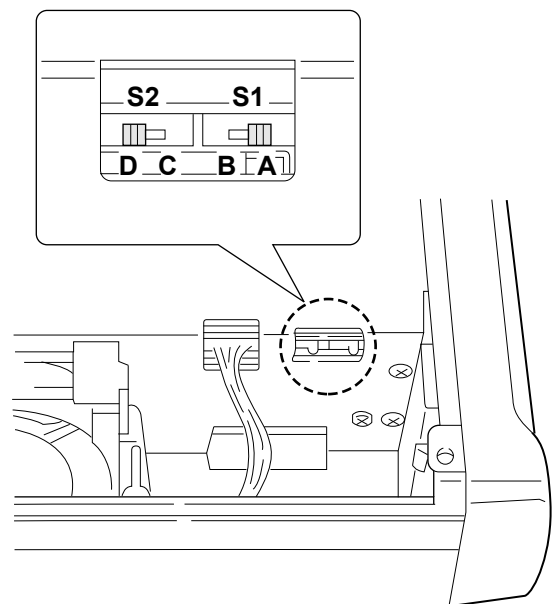

3 OPTIONS

Connecting an external antenna tuner

◇ Using the AT-180

Specifications

Frequency coverage:	1.9–54 MHz
Input impedance:	50 Ω
Maximum input power:	120 W
Minimum tuning power:	8 W
Matching impedance range:	16.7–150 Ω (HF band), 20–125 Ω (50 MHz band)
Tuning accuracy:	Less than SWR 1.5:1
Insertion loss:	Less than 1.0 dB (after tuning)
Power supply requirements:	13.8 V DC/1 A (supplied from the transceiver's ACC socket)
Dimensions (mm/in):	167 (W) \times 58.6 (H) \times 225 (D) mm 6 $\frac{9}{16}$ (W) \times 2 $\frac{5}{17}$ (H) \times 8 $\frac{7}{8}$ (D) in
Weight (approximate):	2.3 kg, 5 lb 1 $\frac{1}{8}$ oz

Supplied accessories

- coaxial cable (1 m),
- ACC cable (DIN 13 pins)

Connector information for the ACC 2 socket

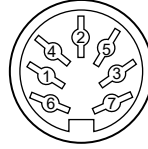

Pin	Description
① 8 V	Regulated 8 V output. (10 mA maximum)
② GND	Connects to ground.
③ SEND	Input/output pin Goes to ground when transmitting (20 mA maximum.) Transmits when grounded.
④ BAND	Band voltage output (Depends on the selected band, 0 to 8.0 V.)
⑤ ALC	ALC output voltage (–4 to 0 V.)
⑥ NC	No connection.
⑦ 13.8 V	13.8 V output when power is ON (1 A maximum.)

[ACC].....	4-2
[MIC].....	4-3
[PHONES]	4-3
[DC 13.8V].....	4-3
[ANT]	4-3
[KEY]	4-3
[REMOTE]	4-4
[EXT SP].....	4-4
[TUNER].....	4-4
[SEND]	4-4
[ALC]	4-4

4 CONNECTOR INFORMATION

[ACC]

Connects to an external equipment or a PC to control an external unit or the transceiver.

ACC	PIN No.	NAME	DESCRIPTION	SPECIFICATIONS
 <p>Rear panel view</p>	1	8 V	Regulated 8 V output.	Output voltage: 8 V \pm 0.3 V Output current: Less than 10 mA
	2	GND	Connects to ground.	—
	3	SEND	Input/output pin. Goes to ground when transmitting. When grounded, transmits.	Ground level: -0.5 V \sim $+0.8$ V Input current: Less than 20 mA
	4	BDT	Data line for the optional AT-180.	—
	5	BAND	Band voltage output. (Varies with amateur band)	Output voltage: 0 \sim 8.0 V
	6	ALC	ALC voltage input.	Control voltage: -4 \sim 0 V Input impedance: More than 10 k Ω
	7	NC	—	—
	8	13.8 V	13.8 V output when power is ON.	Output current: Less than 1 A
	9	TKEY	Key line for the AT-180.	—
	10	FSKK	RTTY keying input.	Ground level: -0.5 \sim 0.8 V Input current: Less than 10 mA
	11	MOD	Modulator input.	Input impedance: 10 k Ω Input level: Approximately 100 mV rms
	12	AF	AF detector output. Fixed, regardless of [AF] position.	Output impedance: 4.7 k Ω Output level: 100 \sim 300 mV rms
	13	SQL S	Squelch output. Goes to ground when squelch opens.	SQL open: Less than 0.3 V/5 mA SQL closed: More than 6.0 V/100 μ A

When using the OPC-599 ADAPTER CABLE

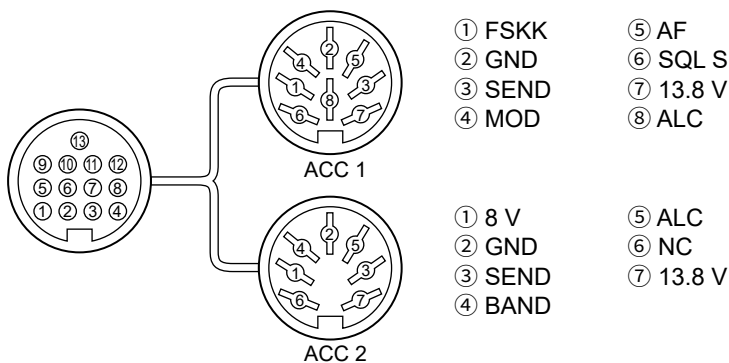

When the SEND terminal controls an inductive load, such as a relay, a counter-electromotive force can malfunction or damage the transceiver. To prevent this, we recommend adding a switching diode, such as an 1SS133, on the load side of the circuit to absorb the counter-electromotive force. When the diode is added, a delay in relay switching may occur. Be sure to check its switching action before operating.

(Example) ACC socket

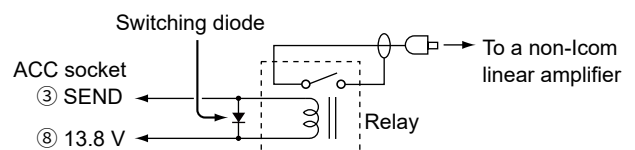

4 CONNECTOR INFORMATION

[MIC]

Connect the supplied microphone.
8-pin connector (600 Ω)

(Front view)

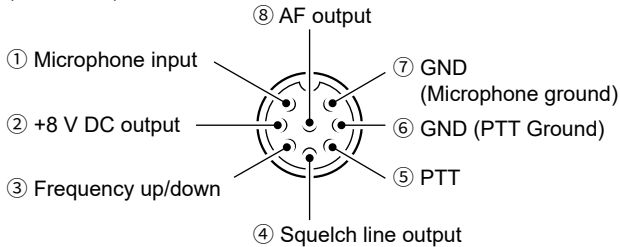

[MIC] PIN No.	FUNCTION	DESCRIPTION
2	+8 V DC output	Maximum 10 mA
3	Frequency up	Ground
	Frequency down	Ground through 470 Ω
4	Squelch open	"LOW" level
	Squelch close	"HIGH" level

CAUTION: DO NOT short the pin 2 to ground, otherwise the internal 8 V regulator may be damaged. DC voltage is also applied to the pin 1 for a microphone operation. Be careful when using a non-Icom microphone.

[PHONES]

Connect standard stereo headphones:
Output impedance: 8 Ω

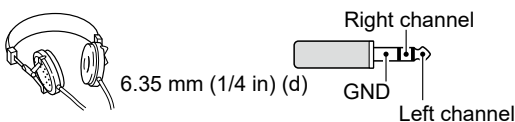

- ① The internal speaker is deactivated while an external speaker is connected.
- ① When high impedance headphones are used, the audio output level may be too high.

[DC 13.8V]

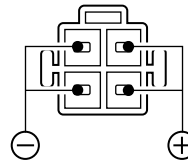

Rear panel view

Accepts the regulated DC power for 13.8 V DC ±15% through the supplied DC power cable.

- **WARNING! NEVER** reverse the DC power cable polarity.

[ANT]

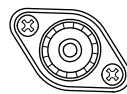

Connect an antenna for HF bands.
Input/Output impedance: 50 Ω
(unbalanced)

[KEY]

Connect a Paddle key or Straight key.

- ① You can select the key type in "Key Type" item in the Initial Set mode.

- Paddle key

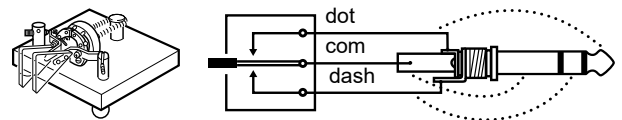

- Straight key

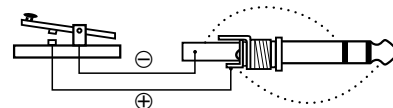

4 CONNECTOR INFORMATION

[REMOTE]

Connects to a PC for remote control using CI-V commands.

3.5 mm (1/8 inch) (d)

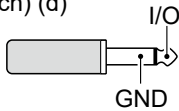

[SEND]

An external unit controls the transceiver. When the SEND pin goes to ground, the transceiver transmits. The terminal goes low when the transceiver transmits. (RCA plug)

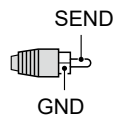

[EXT SP]

Connects an external speaker.
2-conductor, 3.5 mm (1/8 in) (d)
Output impedance: 8 Ω

① The internal speaker is deactivated while an external speaker is connected.

[ALC]

When operating with a non-Icom linear amplifier, input ALC voltage (-4 ~ 0 V) from the linear amplifier. The output impedance and output level differ, depending on the amplifier that is used.

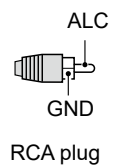

[TUNER]

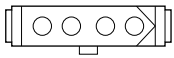

Accepts the control cable from an optional AH-4, AH-730, or AH-740 automatic antenna tuner.

Section 5 CONTROL COMMANDS

◇ Data format.....	5-2
◇ Command table.....	5-3

5 CONTROL COMMANDS

◇ Command table

Command	Sub command	Description
00	—	Send frequency data
01	—	Send mode data
02	—	Read Upper/Lower frequencies
03	—	Read frequencies
04	—	Read operating mode
05	—	Set operating frequency
06	—	Set mode
07	—	Set VFO
	00	Set VFO A
	01	Set VFO B
	A0	VFO A=B
	B0	VFO A δ B
08	—	Set Memory
	—	Set Memory CH
09	—	Memory write
0A	—	Memory δ VFO
0B	—	Memory clear
0E	00	Scan stop
	01	Prog/Memo Scan Start
	D0	Resume OFF
	D3	Resume ON
0F	00	SPLIT OFF
	01	SPLIT ON
10	—	Set TS
11	—	ATT
14	01	AF Gain
	02	RF Gain
	03	SQL Level
	06	NR Level
	09	CW Pitch
	0A	RF Power
	0B	MIC Gain
	0C	KEY Speed
	0F	BK-IN Delay
15	01	Read SQL Open/Close
	02	Read SIG (S-meter) level
16	02	PRE-AMP
	22	NB
	40	NR
	41	Auto Notch
	44	COMP
	46	VOX
	47	BK-IN
19	00	Read ID

